



PRODUCT FEATURES

Thermostatic bath and shower faucets adjust the water to the desired temperature and ensure its flow at this temperature. This ensures that there is no risk of scalding with hot water due to problematic water adjustment and temperature changes in the installation. If the water is out, the cartridge inside the product is automatically locked and prevents water from flowing out of the product. This completely eliminates the risk of scalding with hot water.

Thanks to the flywheel with a 90° opening - closing shaft, you can adjust the water amount while keeping the water temperature constant.

VitrA thermostatic battery models, consist of four models consisting of built - in shower - bath and wall - mounted shower - bath. All models are comfortable and easy to use and are used in the same way. The faucets have a button on the flywheel where the cartridge is located. This button is where the temperature is set to 38° C in the factory. When you desire a higher temperature, simply push the button and turn the flywheel in the direction of the arrow. Although operation is easy for adults, it is safe enough to prevent children and the elderly from accidentally scalding themselves. The thermostatic cartridge is manufactured to provide a maximum hot water temperature of 45° C. The special alloy metal inside the thermostatic cartridge moves instantly even at sudden water pressure changes, allowing water to flow at the desired temperature.

Before mounting the wall-mounted thermostatic bath and shower faucets, be sure that check-valves are installed on the nipples. If the check-valves are missing, do not mount your faucet in this way.

The built-in thermostatic bath and shower faucet has embedded version of check-valves.

In order to operate the thermostatic batteries efficiently, the dynamic pressure in the hot and cold water infrastructure has to be at least 1 bar. The difference of pressure should not exceed 0.5 bar between hot and cold water.

	P	P bar		
	T	°C		

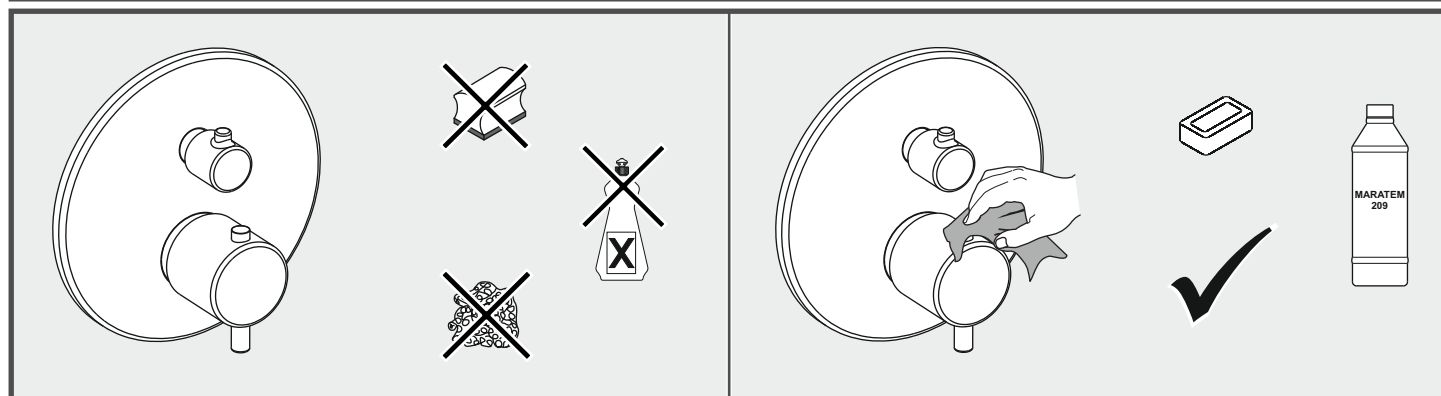

Adresses sur quefairedemesdechets.fr