

CLASSICO 2424



INSTRUCTIONS DE MONTAGE MONTAGE HANDLEIDING ASSEMBLY INSTRUCTIONS MONTAGEANLEITUNG

Projet numéro / Project nummer / Project number / Projekt Nummer :

.....

QC-numéro / QC-nummer / QC-number / QC-Nummer :

.....

Couleur / Kleur / Colour / Farbe:

Blanc, Wit, White, Weiß

Gris clair, Licht grijs, Light grey, Lichtgrau

Anthracite, Antraciet, Anthracite, Granitgrau

Nous vous invitons à lire attentivement le présent mode d'emploi. Vous y trouverez les caractéristiques techniques ainsi que toutes les informations utiles en vue d'un fonctionnement correct. Les données techniques figurant dans cette publication peuvent être modifiées à tout moment et sans avis préalable et ce, pour des raisons techniques ou commerciales..

Wij nodigen u uit deze handleiding aandachtig te lezen. Ze omvat de technische eigenschappen en alle nuttige informatie voor een correcte werking. De technische gegevens in deze publicatie kunnen om technische of commerciële redenen op elk moment en zonder voorafgaande kennisgeving worden gewijzigd.

Please read this manual carefully. It contains the technical properties and all the information required for correct operation. The technical data in this publication is subject to change for technical and/or commercial reasons at any time and without notice.

Bitte lesen Sie diese Anleitung sorgfältig durch. Sie enthält die technischen Eigenschaften und alle Informationen, die für einen korrekten Betrieb erforderlich sind. Die in dieser Publikation enthaltenen technischen Daten können jederzeit ohne Vorankündigung aus technischen oder kommerziellen Gründen geändert werden.



Lisez bien l'ensemble du mode d'emploi avant de commencer à réaliser des travaux.

Lees de volledige handleiding voordat u begint met de werken uit te voeren.

Read the entire manual before you start working.

Lesen Sie vor Arbeitsbeginn die gesamte Anleitung.



L'utilisation de gants est obligatoire.

Het gebruik van handschoenen is verplicht.

The use of gloves is mandatory.

Das Tragen von Handschuhen ist Pflicht.



L'utilisation de lunettes de protection est obligatoire.

Het gebruik van een veiligheidsbril is verplicht.

The use of safety glasses is mandatory.

Das Tragen einer Sicherheitsbrille ist Pflicht.



L'utilisation d'un casque de protection est obligatoire.

Het gebruik van een veiligheidshelm is verplicht.

The use of a hard hat is mandatory.

Das Tragen eines Sicherheitshelms ist Pflicht.



L'utilisation d'une meule est interdite

Het gebruik van een slijpschijf is verboden

The use of an angle grinder is prohibited

Die Verwendung einer Schleifscheibe ist verboten



Déballage à 2 personnes

Met 2 personen uitpakken

Unpack with 2 people

Auspacken mit 2 Personen



Retirer les éclats de métal.

Metaalsplinters verwijderen

Cleaning up metal splinters

Metallsplinter entfernen

Liste d'outils / Gereedschappenlijst / Tools List / Werkzeugliste

Liste des composants / Stukslijst / Partslist / Teileliste

Pour la liste actuelle des pièces, voir pièce jointe.
 Voor de actuele stuklijst zie bijlage.
 For the current parts list see attachment.
 Aktuelle Stückliste siehe Anhang.

Eleganto Lounge Small / 3024 / Anthracite / Right									
EP.GRT.ANT.3024PHR									
21569.1									
KST.06 x1	S.3024PHR x1	B6 x33	F6 x10	SSP x1	WP45 x1	S6PH x2			
FD18 x1	FP42 x2	FP41 x1	JN47 x2	J27 x2	J27 x1	J27R x1			
J21 x3	J21S x3	W2 x1	W18 x1	W21 x11	S.DA2TV x1				
S.DA4S x6	K.EAV.2CVR x1	HPH x1	HA4 x4	K.E218D x1	K21PHA x1	K.E27AC x1			
SP48 x1	SP48 x2	SP48 x1	SP48 x1	SP48 x1	SP48 x1	SP48 x1			
K.E2PHR x1	A21 x3	A27 x1	A27 x2	M21 x3	M27 x3	B.05 x1			
S.04P x1	SE x2	SSD x1	SEL1 x1						

EXEMPLE / VOORBEELD
 EXAMPLE / BEISPIEL

Fundament

- Le sol doit être plat et de niveau. Le sol doit être réalisé pour permettre une fixation adéquate de l’abris de jardin.
- De vloer moet vlak en waterpas zijn. De vloer moet gemaakt worden zodat de bevestiging van het tuinhuis wel mogelijk is.
- The floor must be flat and level. The floor must be made in such a way that it is possible to fix the garden house.
- Der Aufbauort muss eine flache, geschlossene und in Waage liegende Bodenplatte aufzeigen. Die Bodenplatte muss so beschaffen sein, das eine mechanische Befestigung von dem CLASSICO erfolgen kann.

PS

- L’abris de jardin doit être centrée sur la dalle de béton.
- Het tuinhuis moet gecentreerd geplaatst worden op het fundament.
- The garden house must be centered on the foundation.
- Das Gartenhaus muss auf dem Fundament zentriert sein.

Tous les éléments / Alle elementen / All elements / Alle Elemente

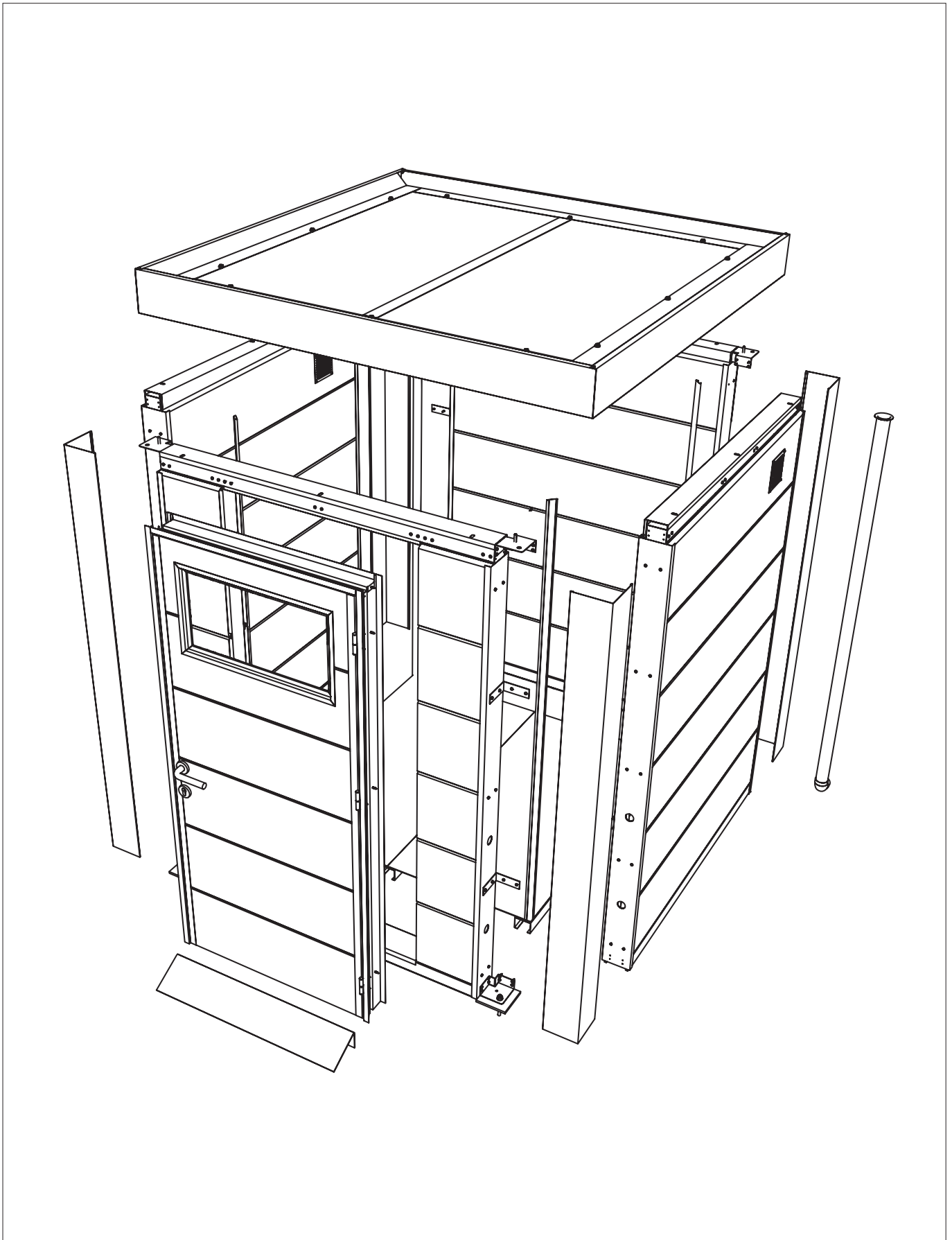

Composition / Compositie / Composition / Zusammensetzung

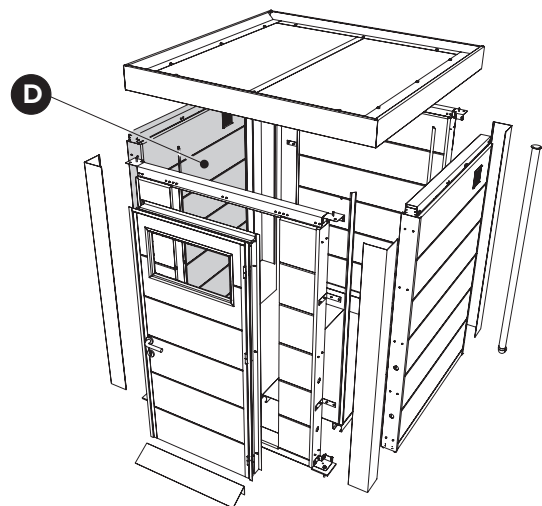
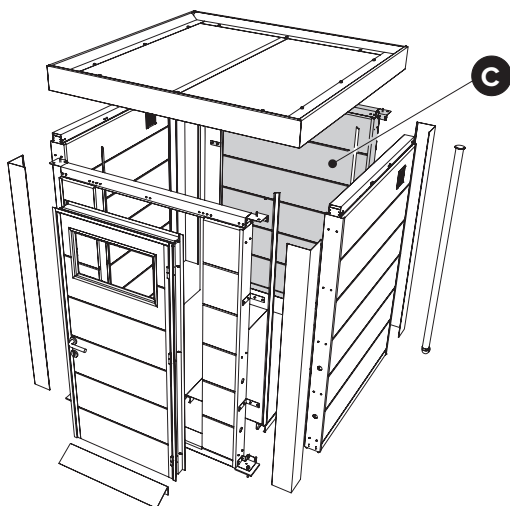
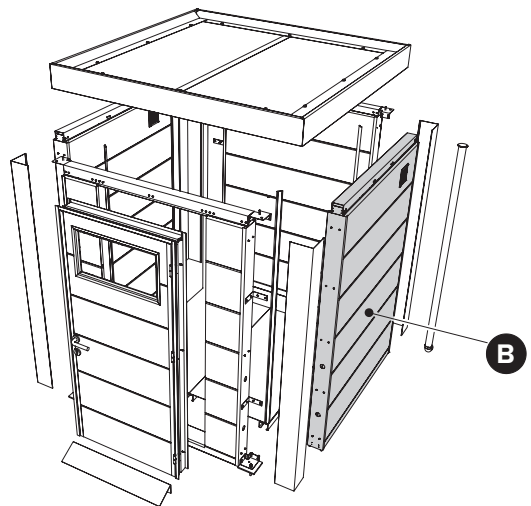
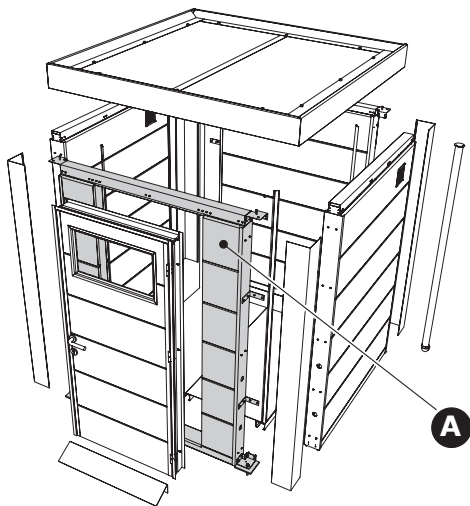
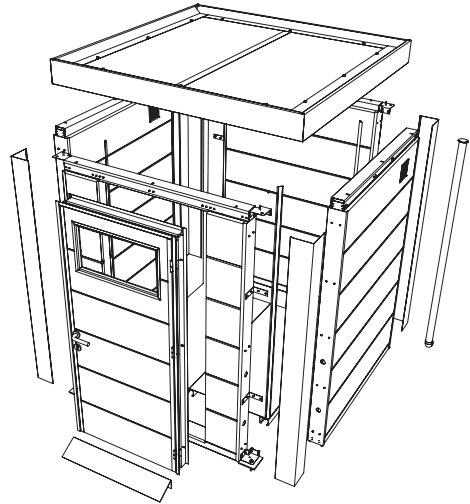
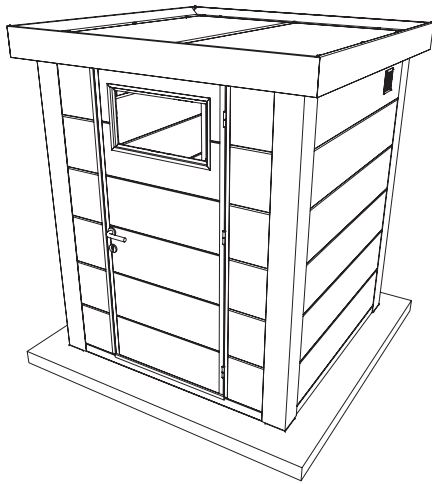

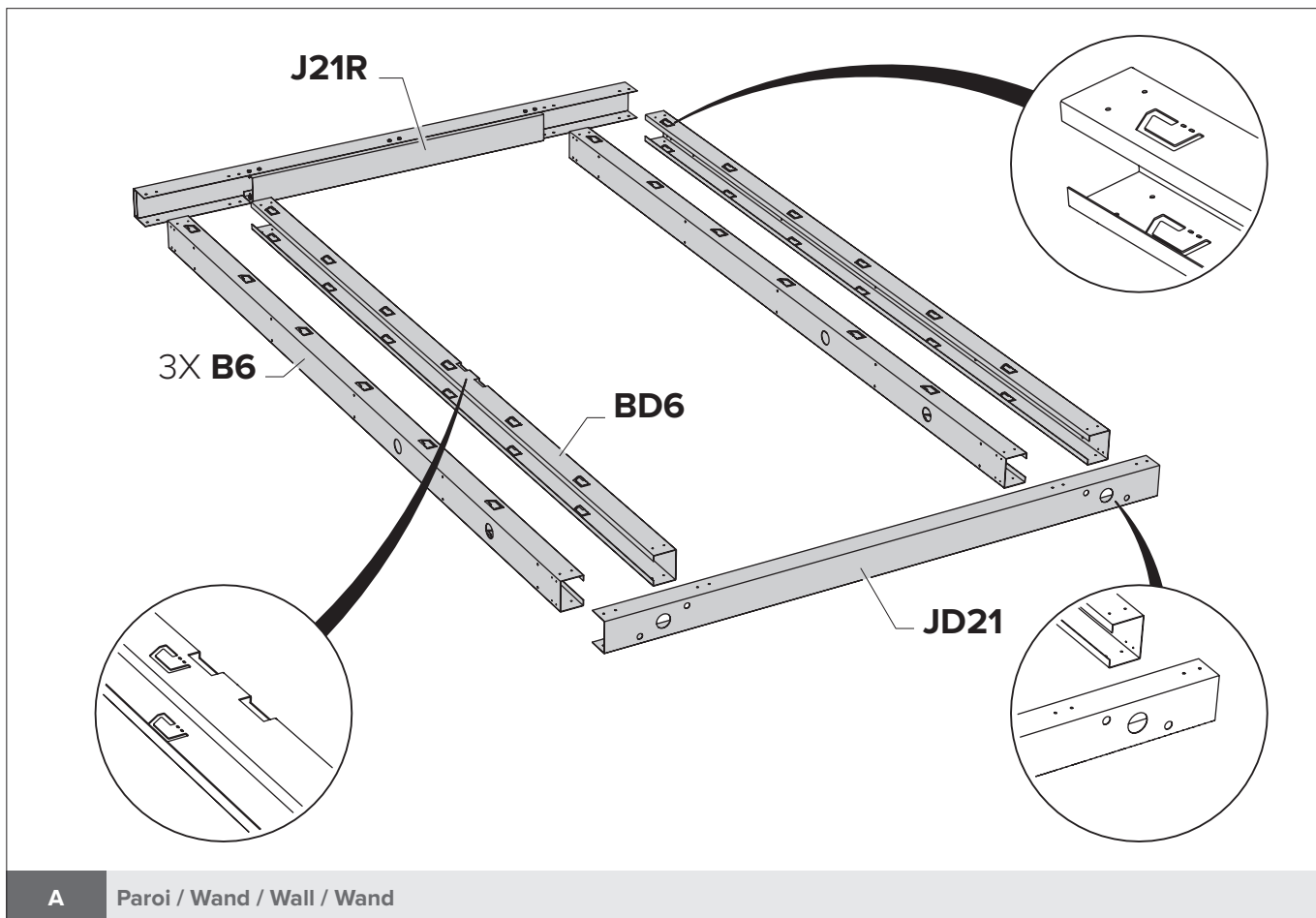
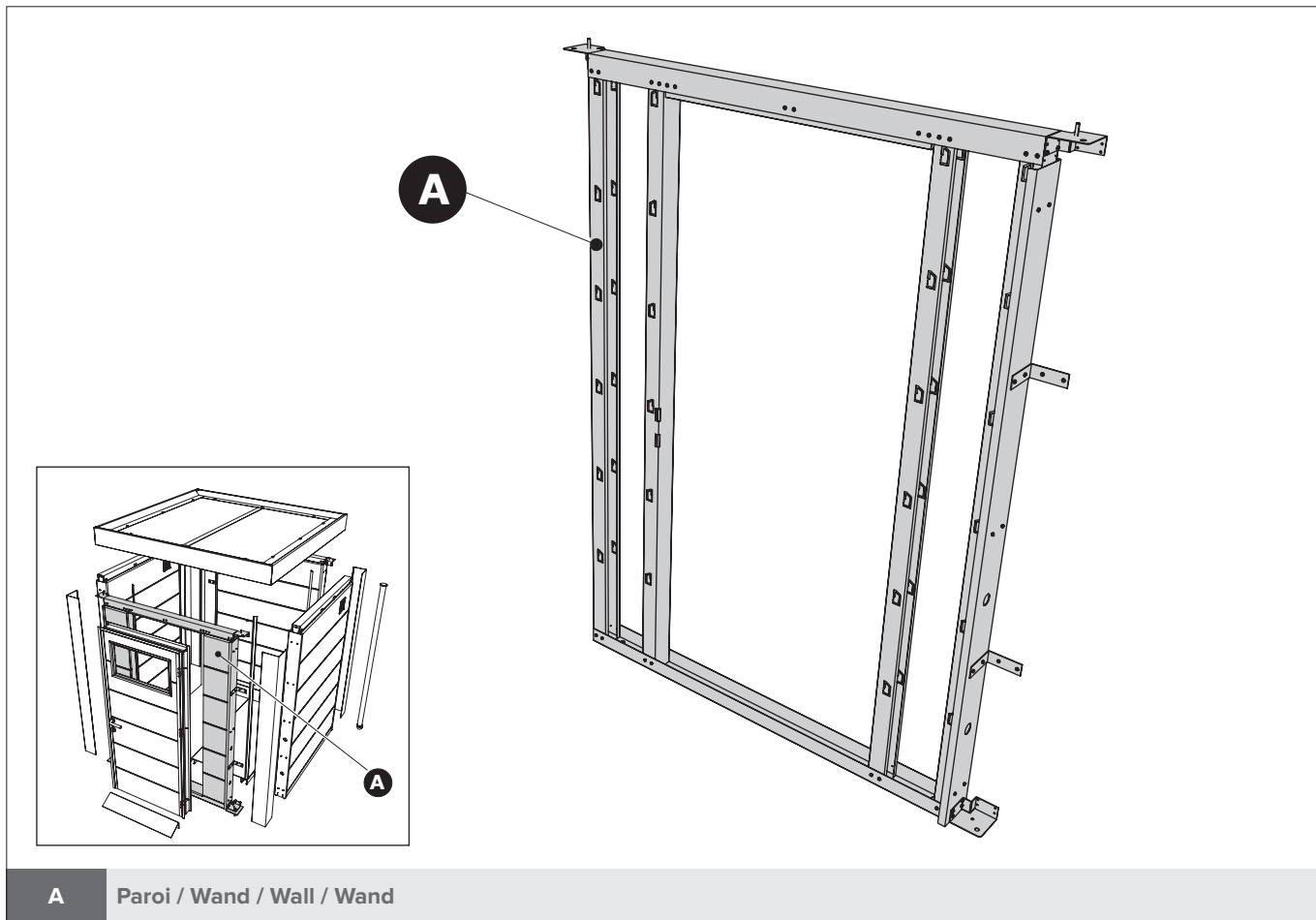

Le principe de la construction du mur (POW).
 Het principe van de opbouw van de wand (POW).
 The principle of building the wall (POW).
 Aufbau der Wandelemente (POW).

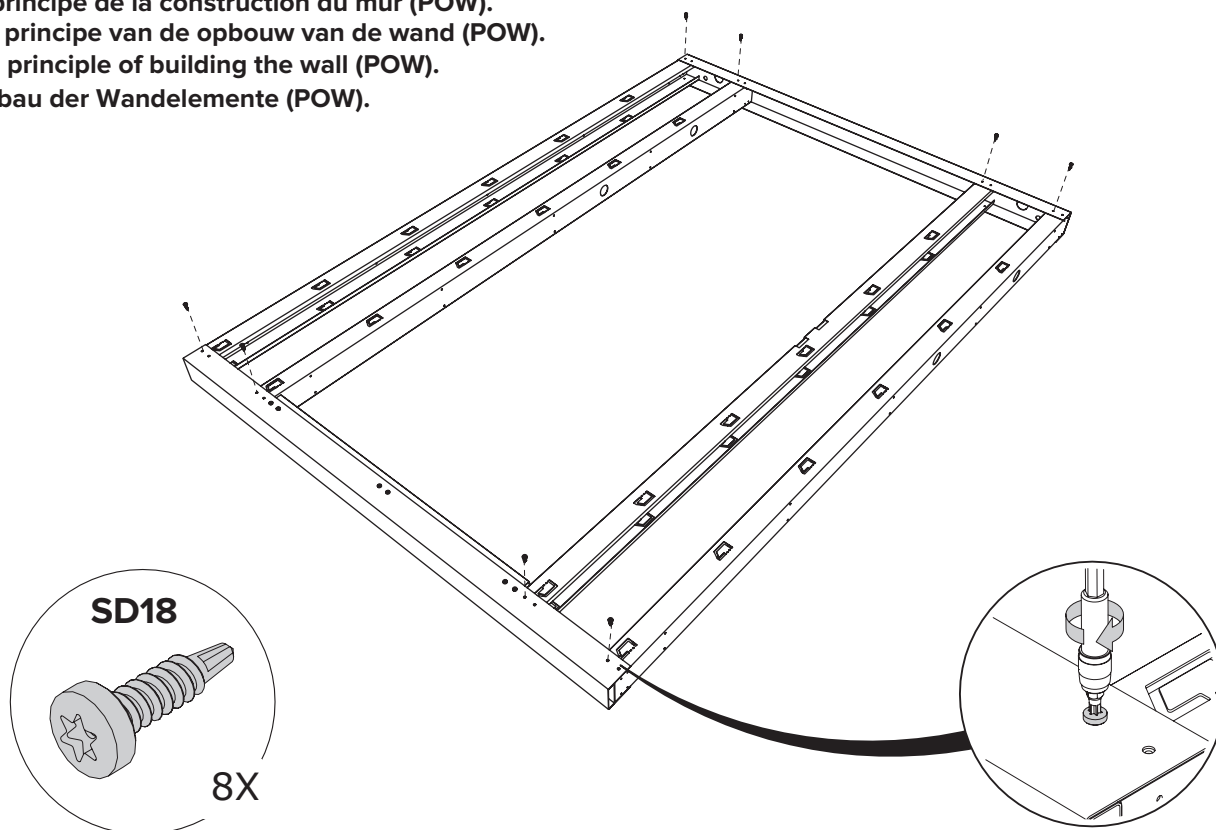

A Paroi / Wand / Wall / Wand

POW

Tourner encadrement / Kader omdraaien / Turn Frame / Rahmen umdrehen

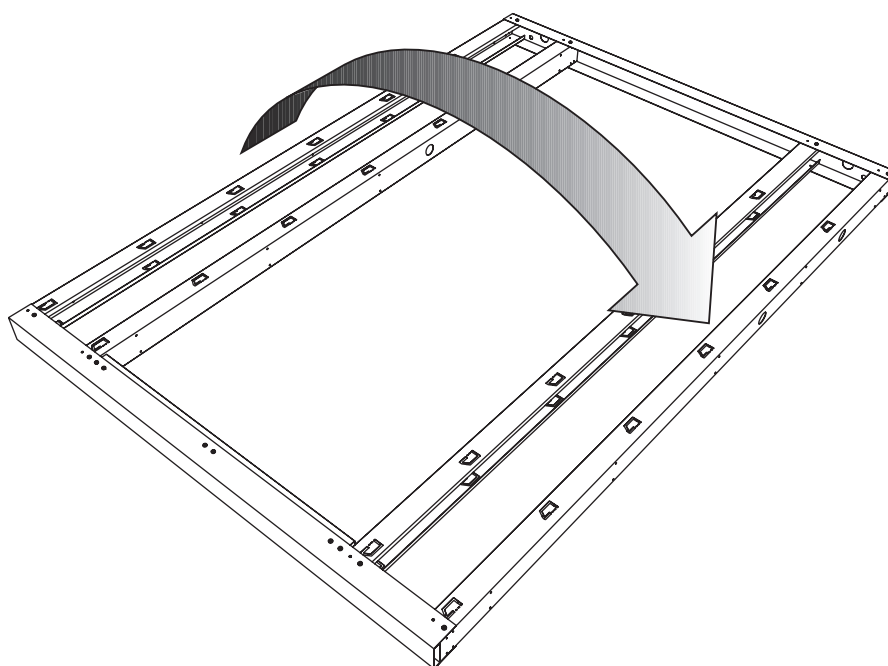

A Paroi / Wand / Wall / Wand

POW

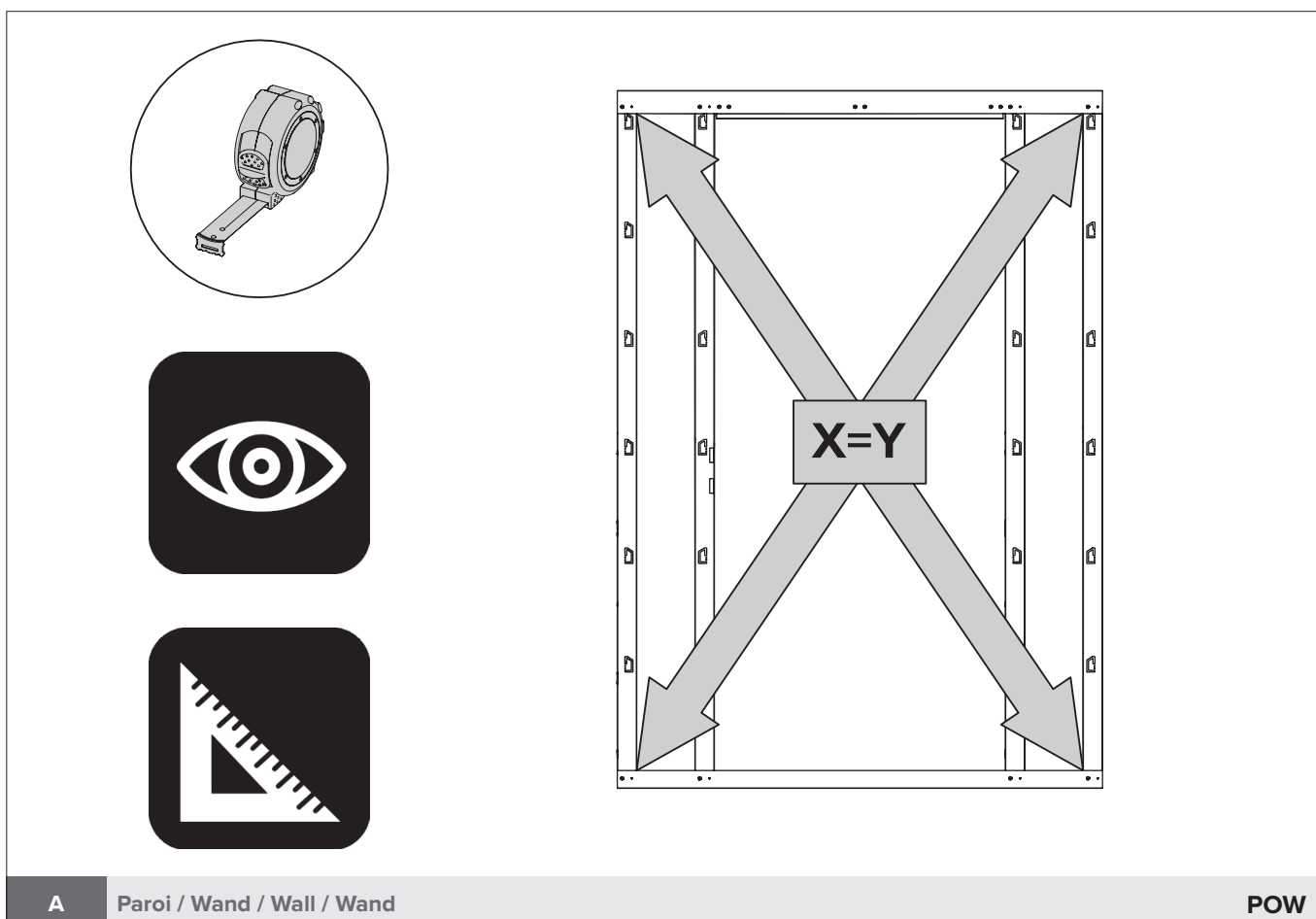
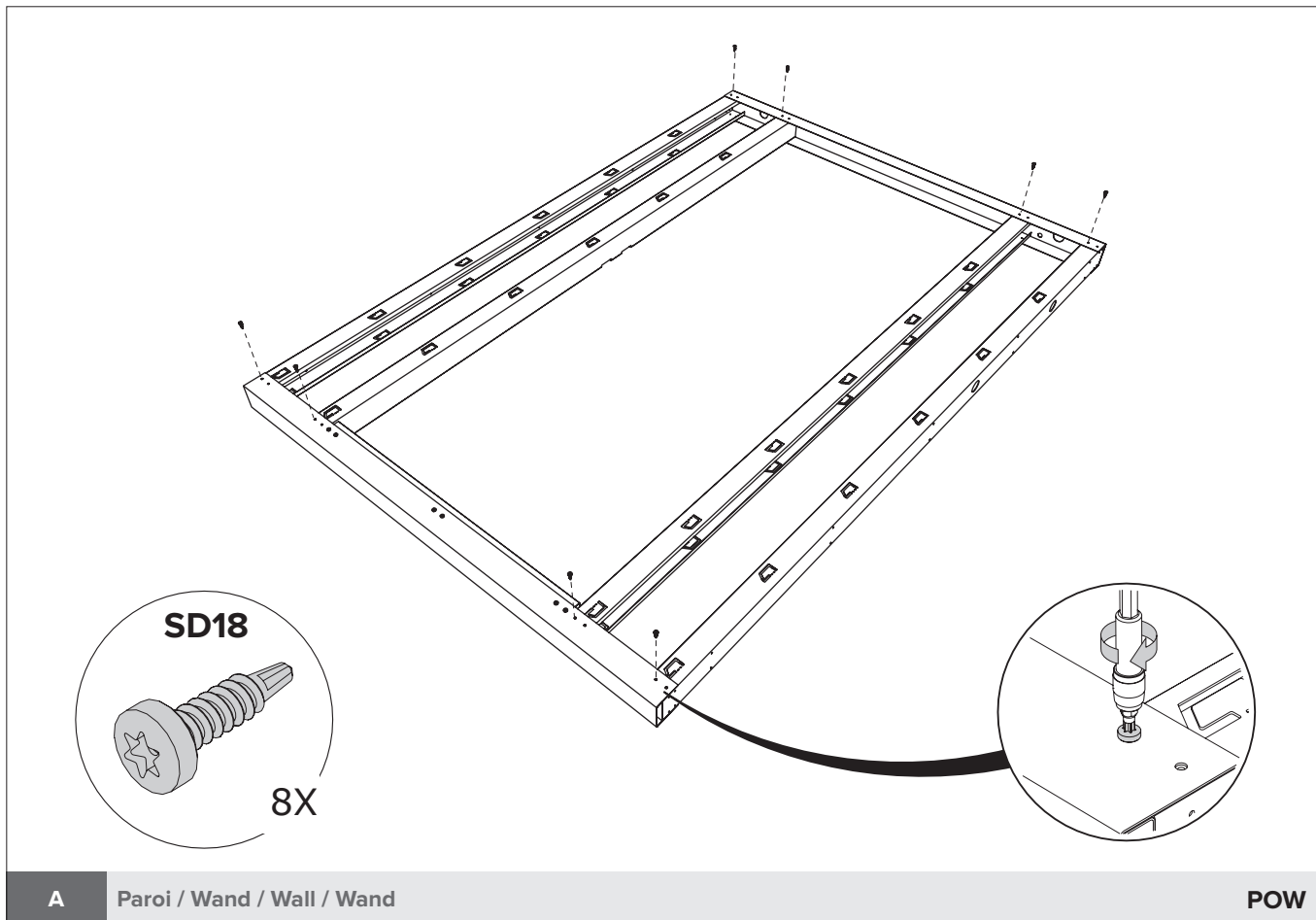

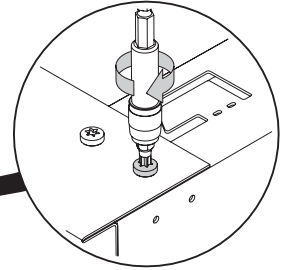
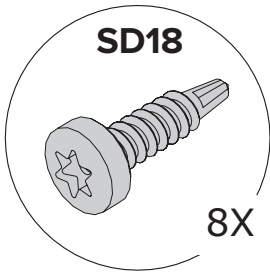
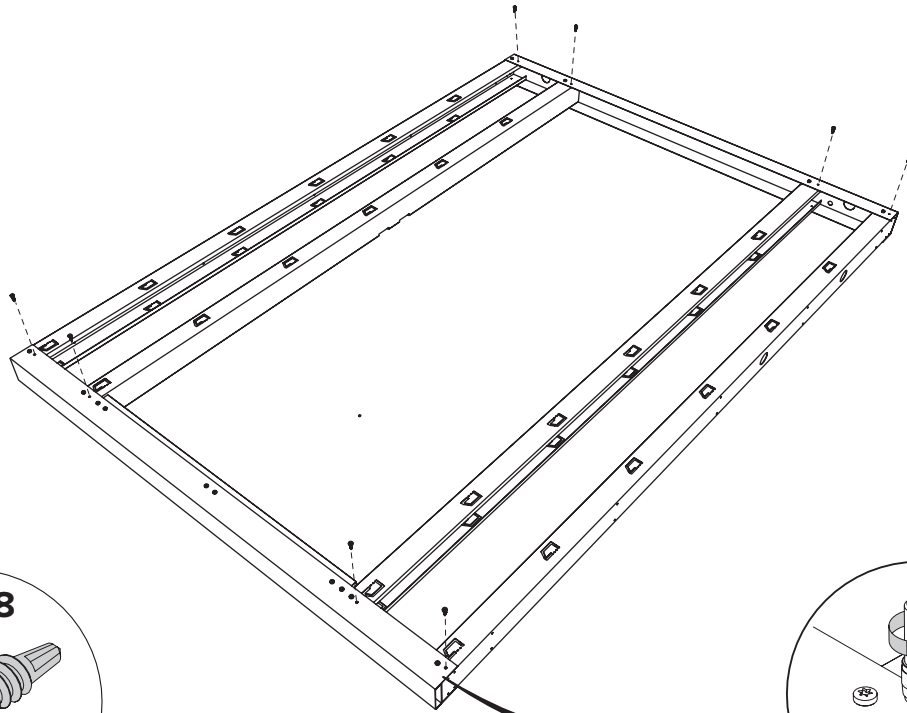

A

Paroi / Wand / Wall / Wand

POW

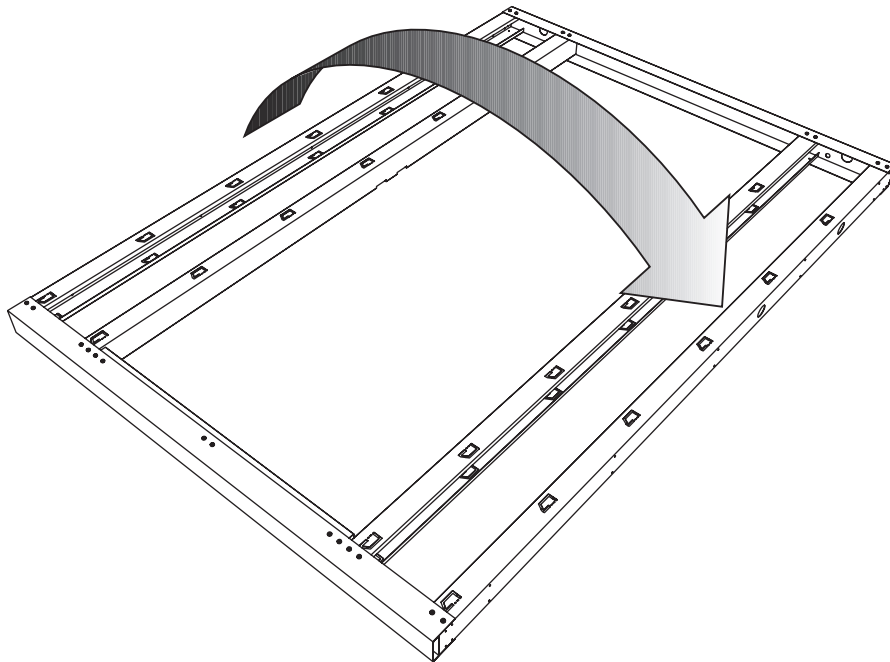

A

Paroi / Wand / Wall / Wand

POW

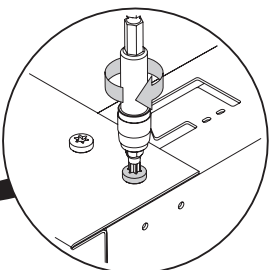
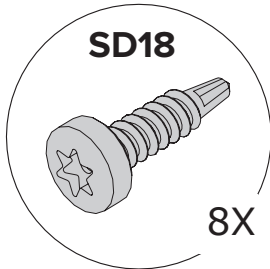
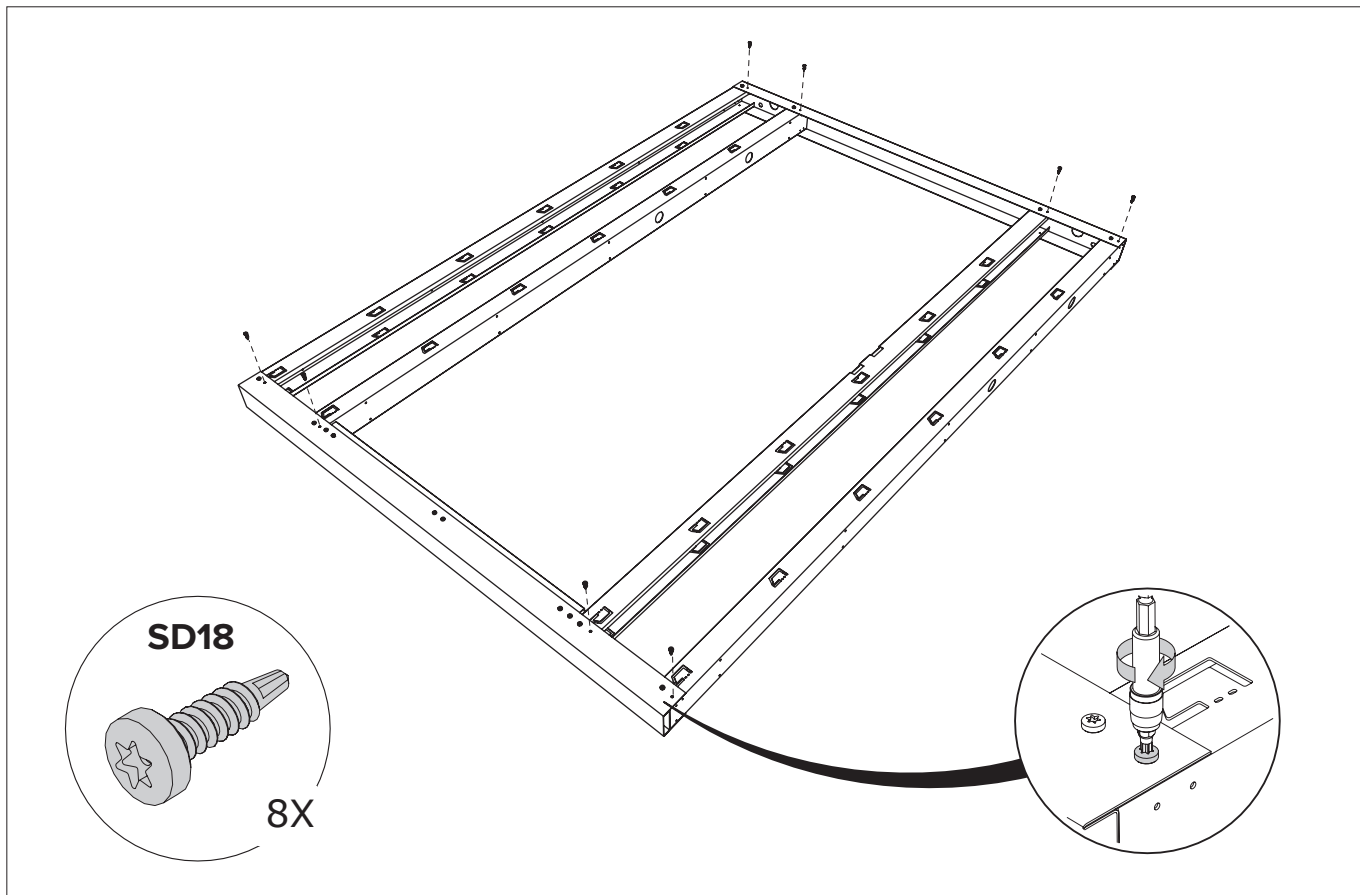

A Paroi / Wand / Wall / Wand **POW**

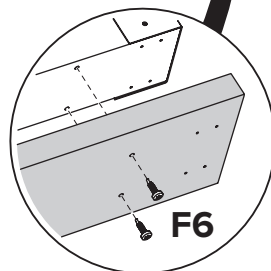
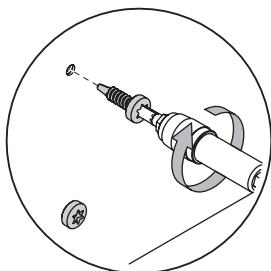
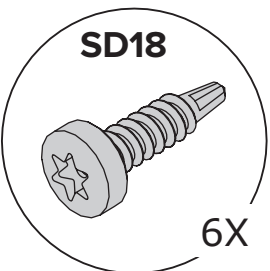
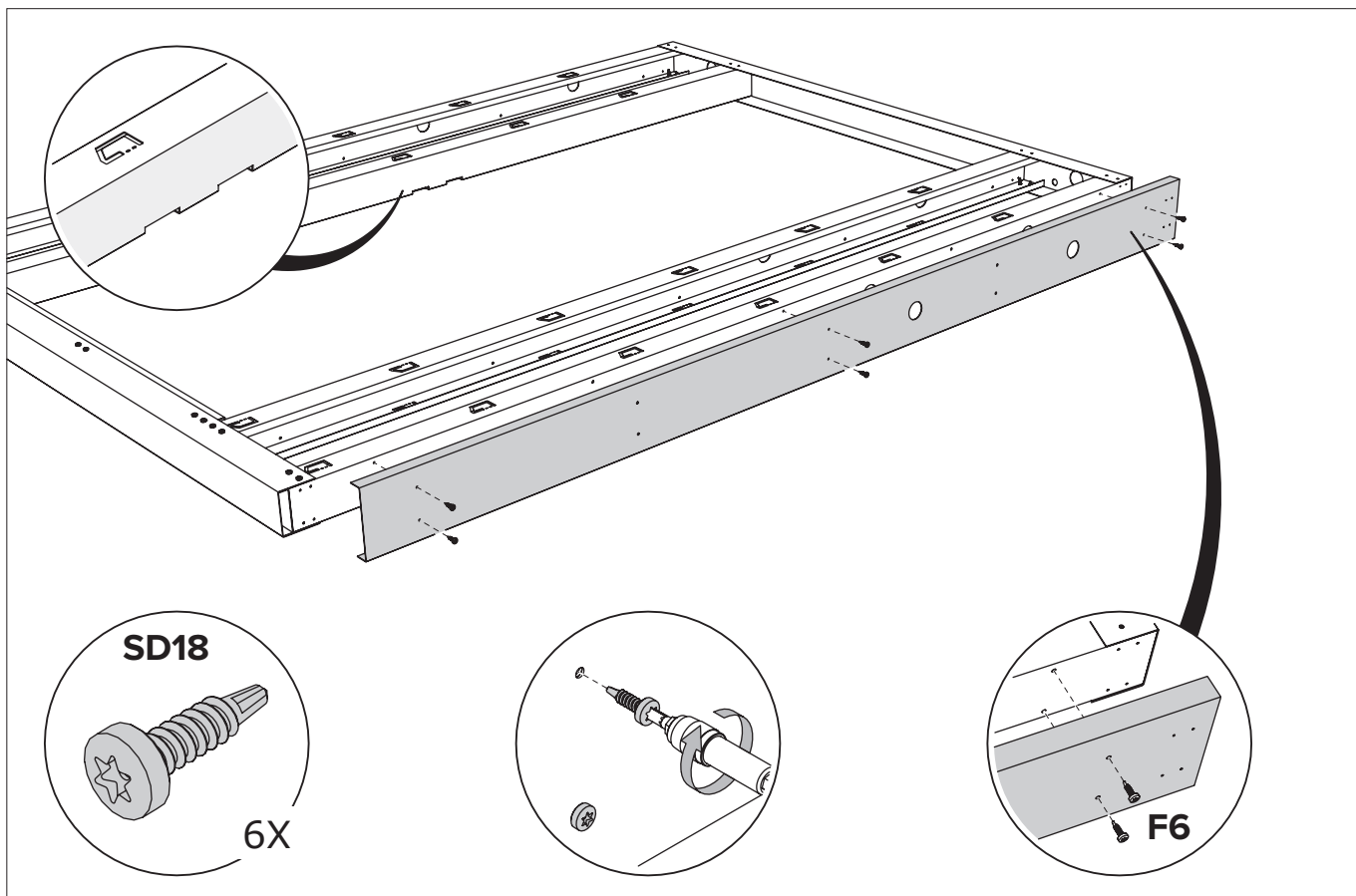

A Paroi / Wand / Wall / Wand

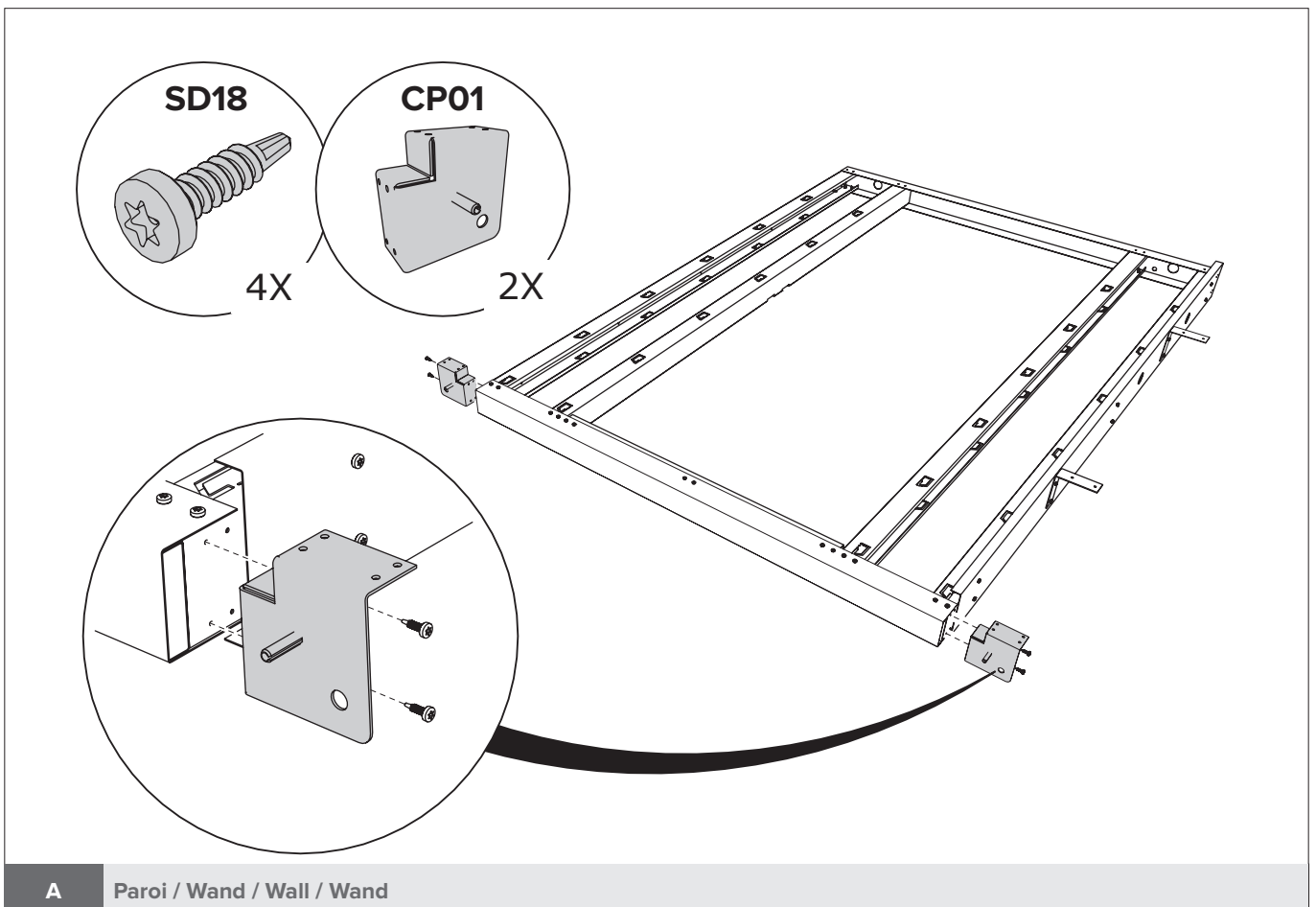
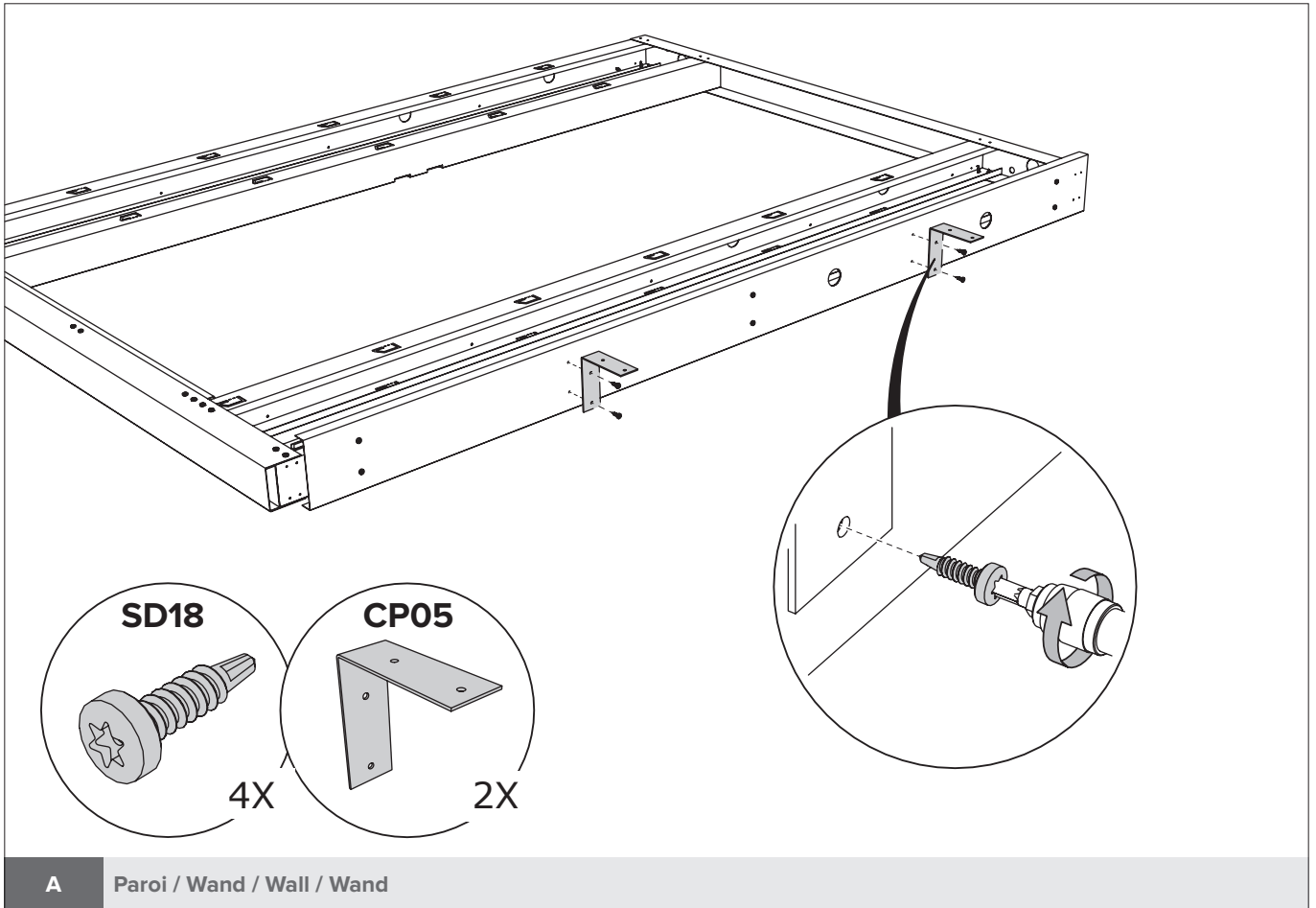

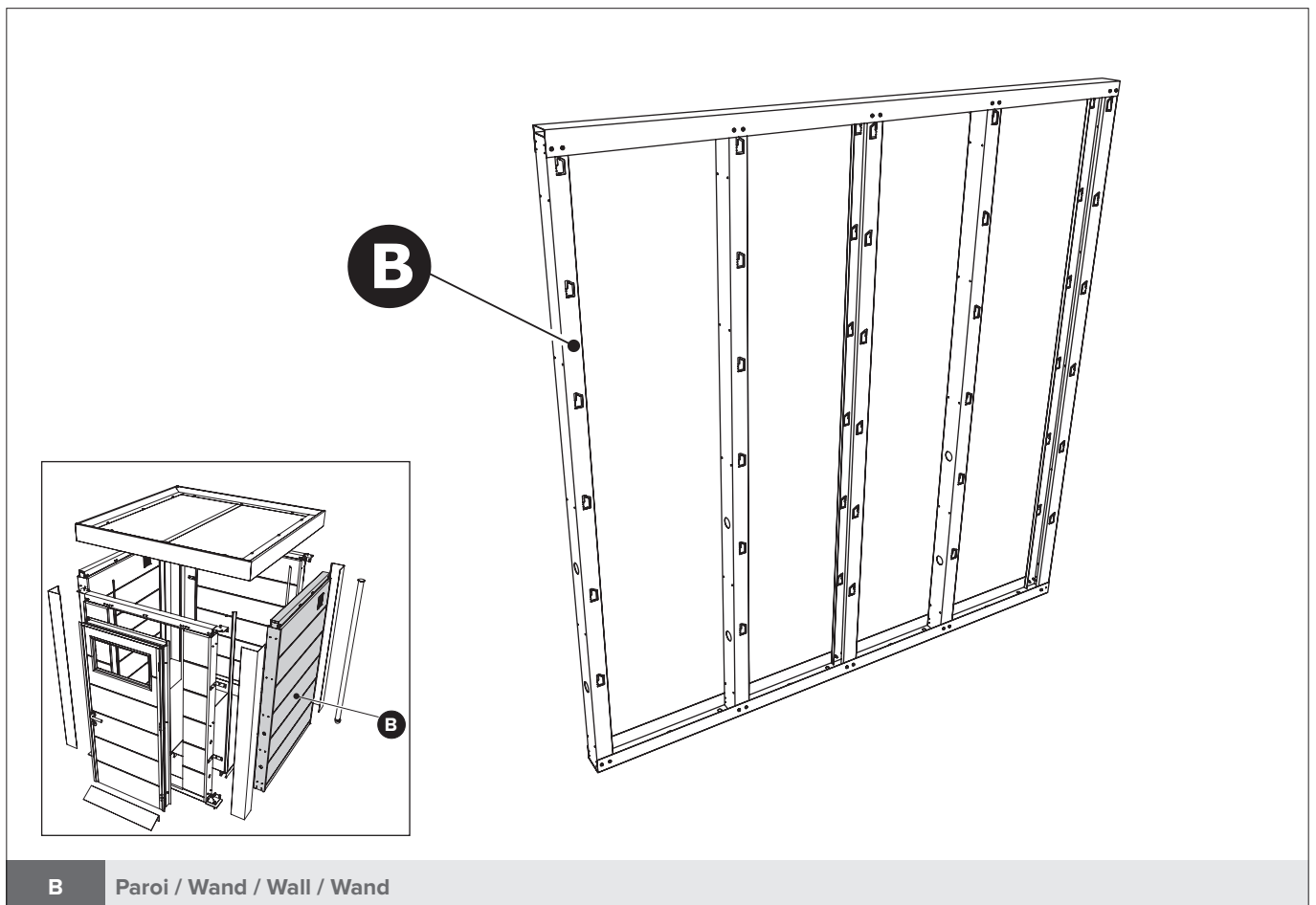
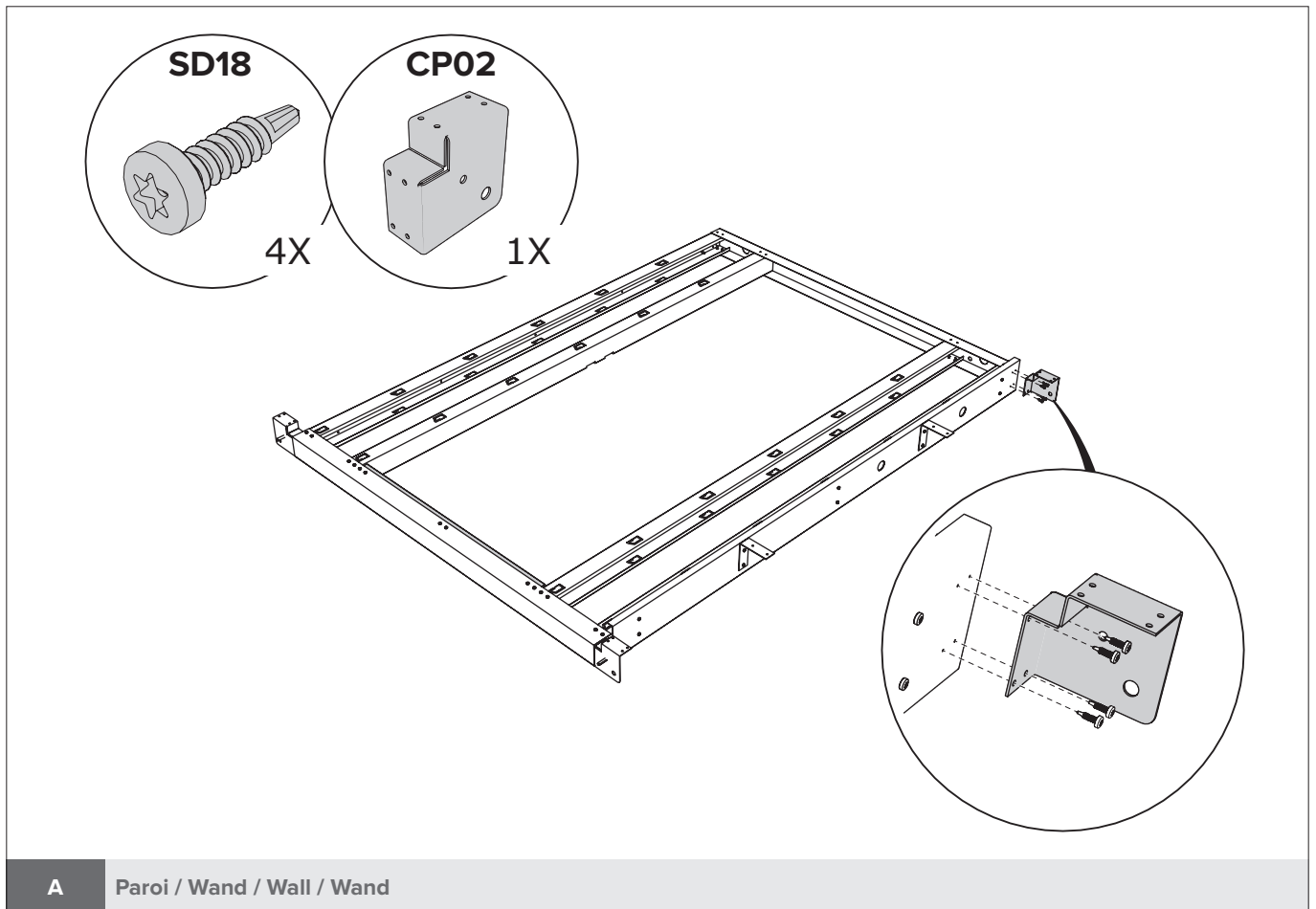

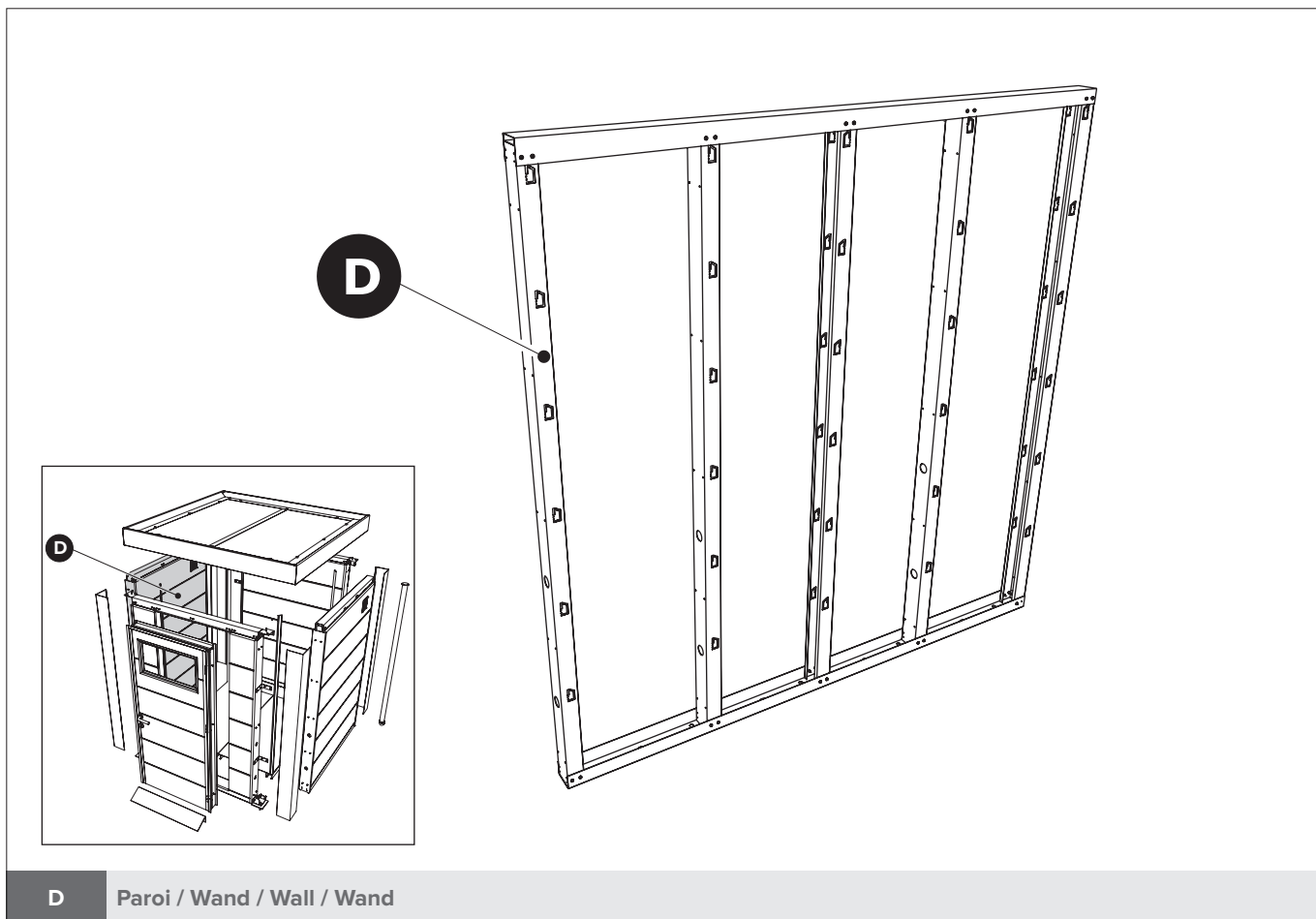

D Paroi / Wand / Wall / Wand

Le principe de la construction du mur, voir pages 8 à 11 (POW).
 Het principe van de opbouw van de wand, zie pagina 8 tot en met 11 (POW).
 The principle of building the wall, see pages 8 through 11 (POW).
 Aufbau der Wandelemente Sie auf den Seiten 8 bis 11 (POW).

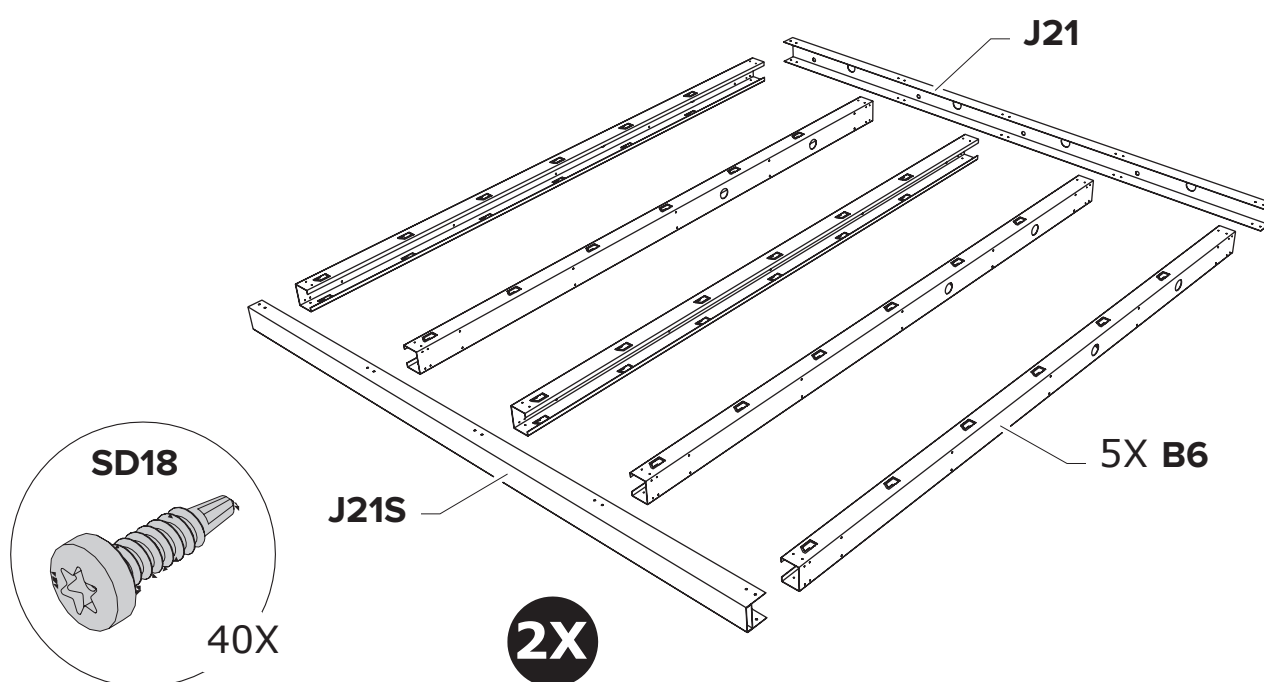

B / D Paroi / Wand / Wall / Wand

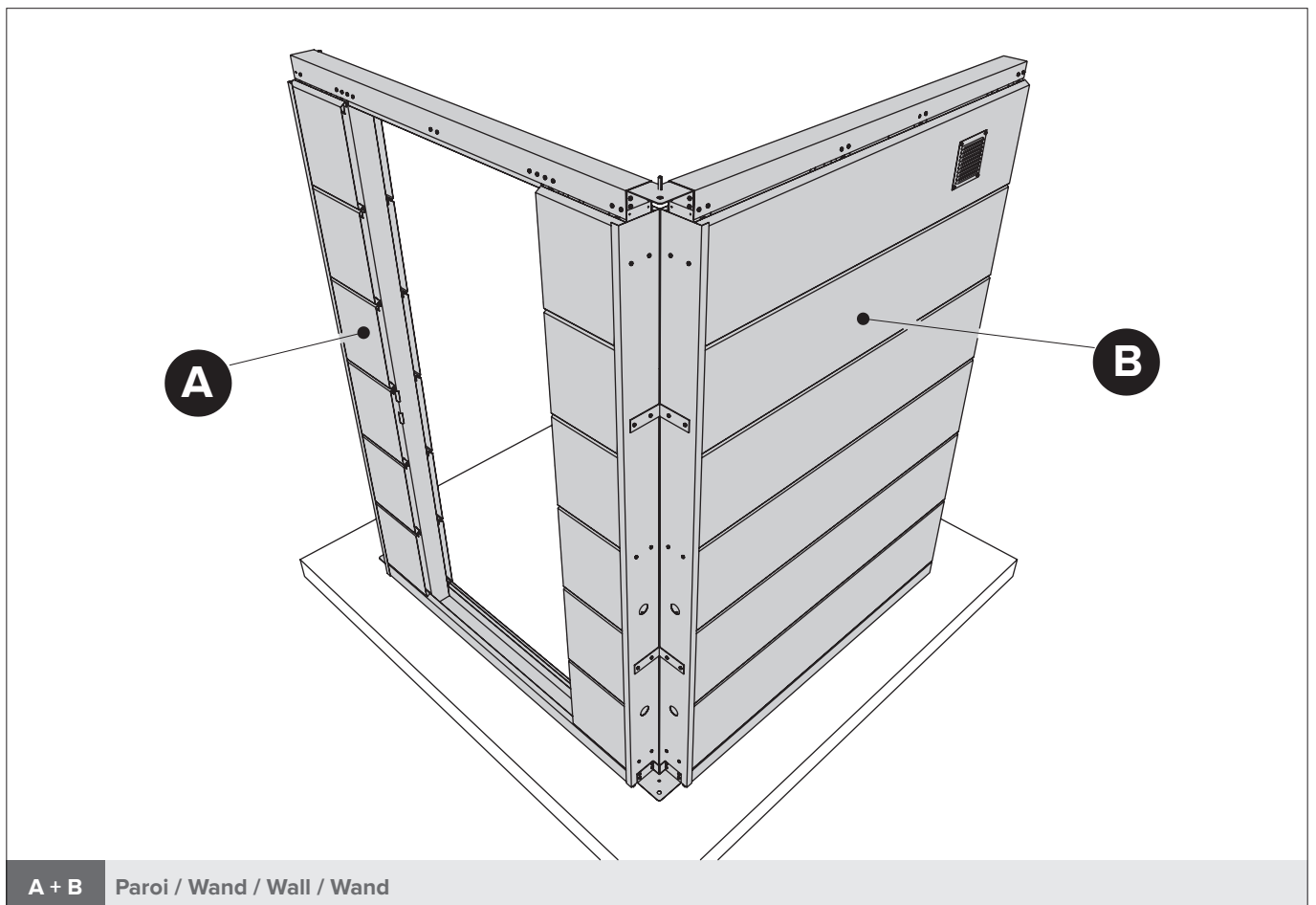
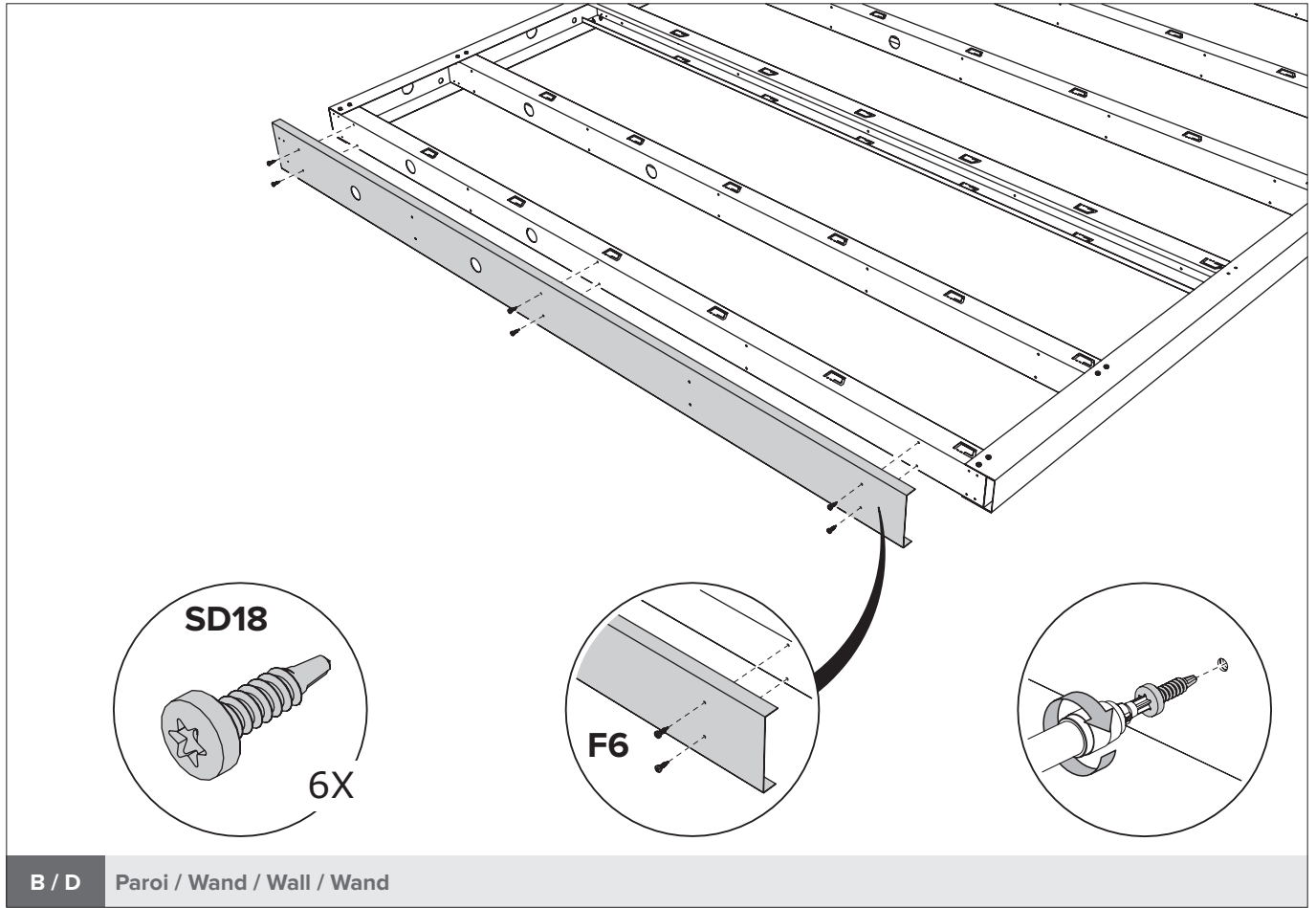

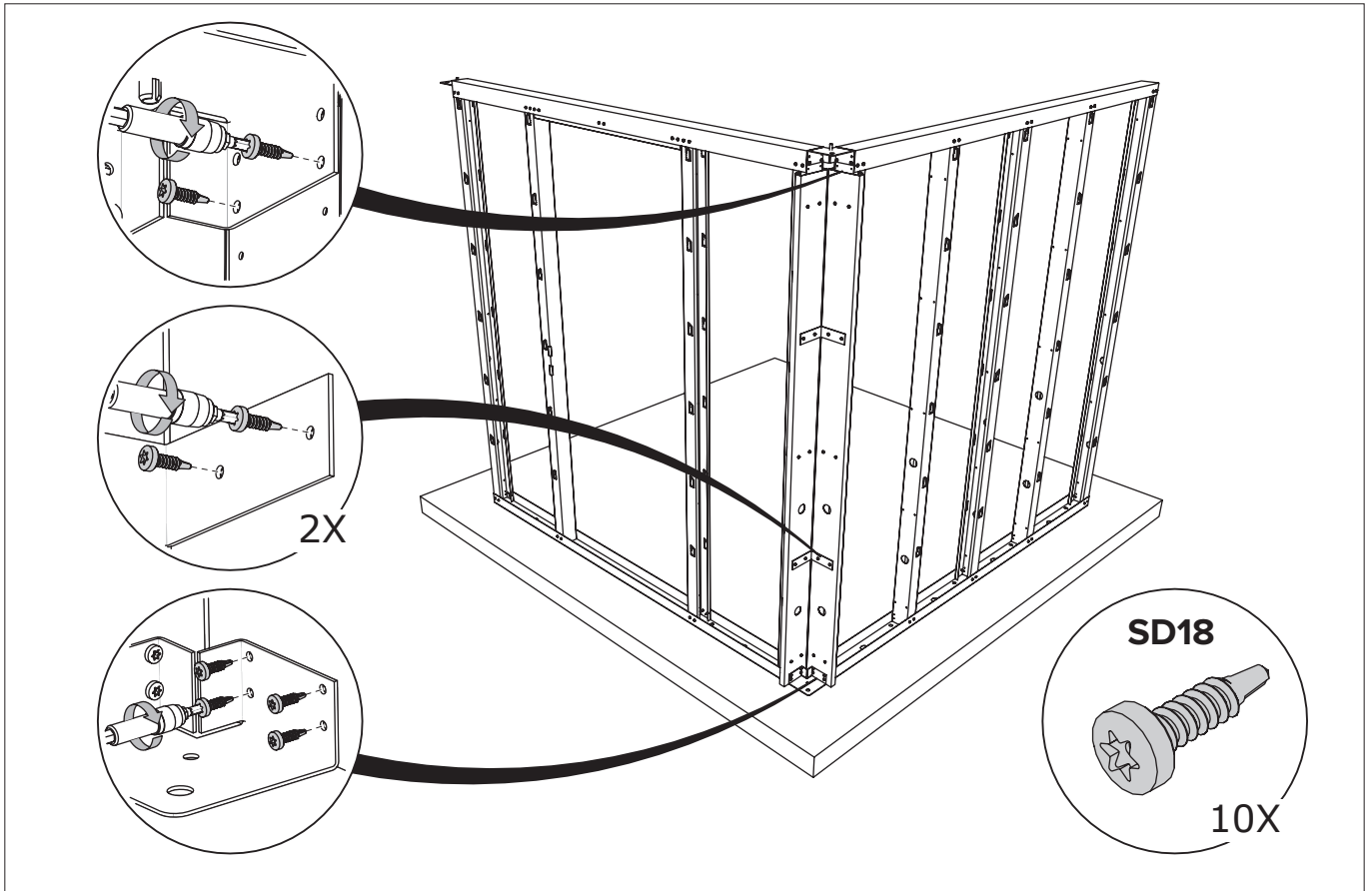

A + B Paroi / Wand / Wall / Wand

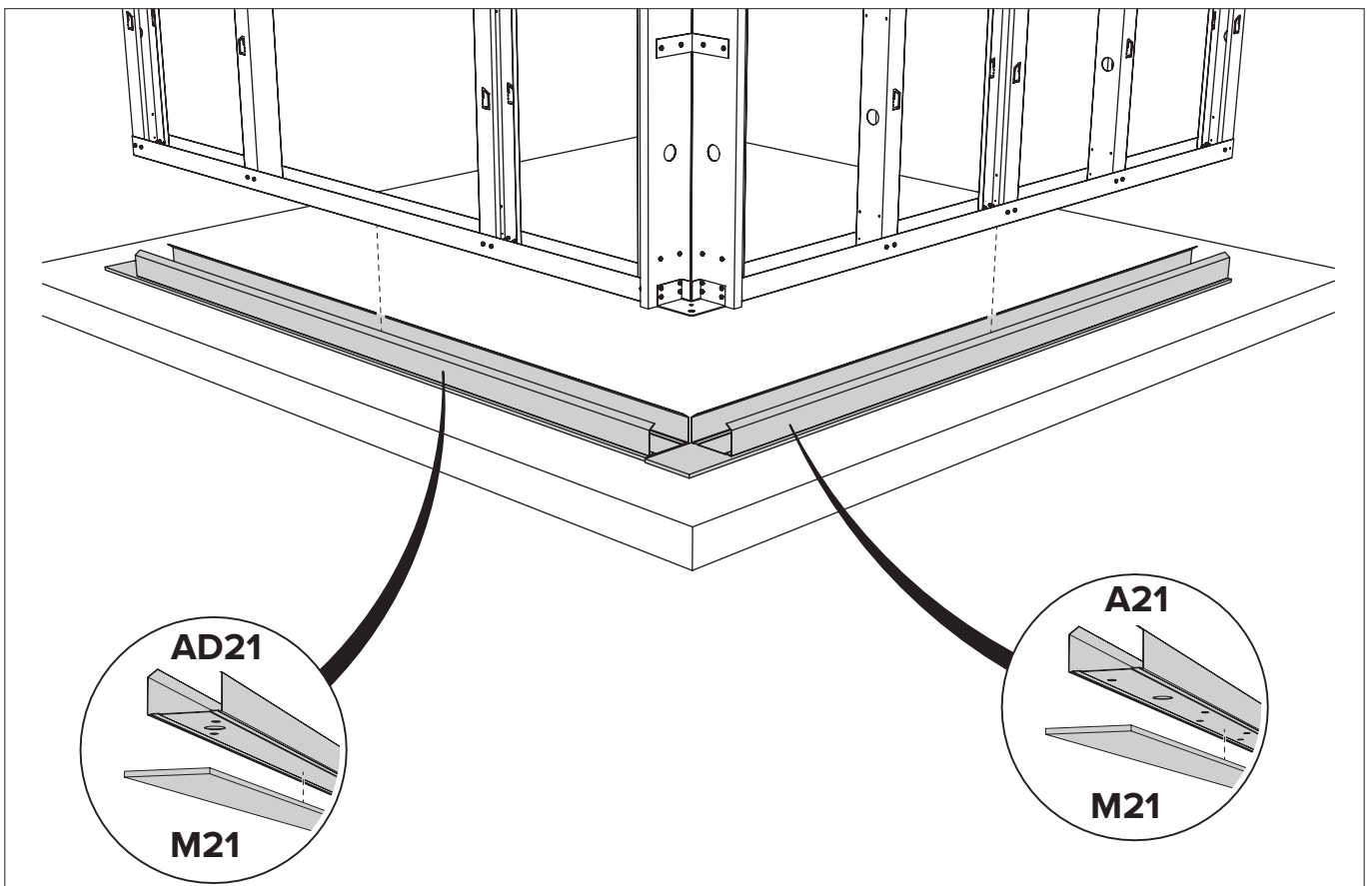

A + B Paroi / Wand / Wall / Wand

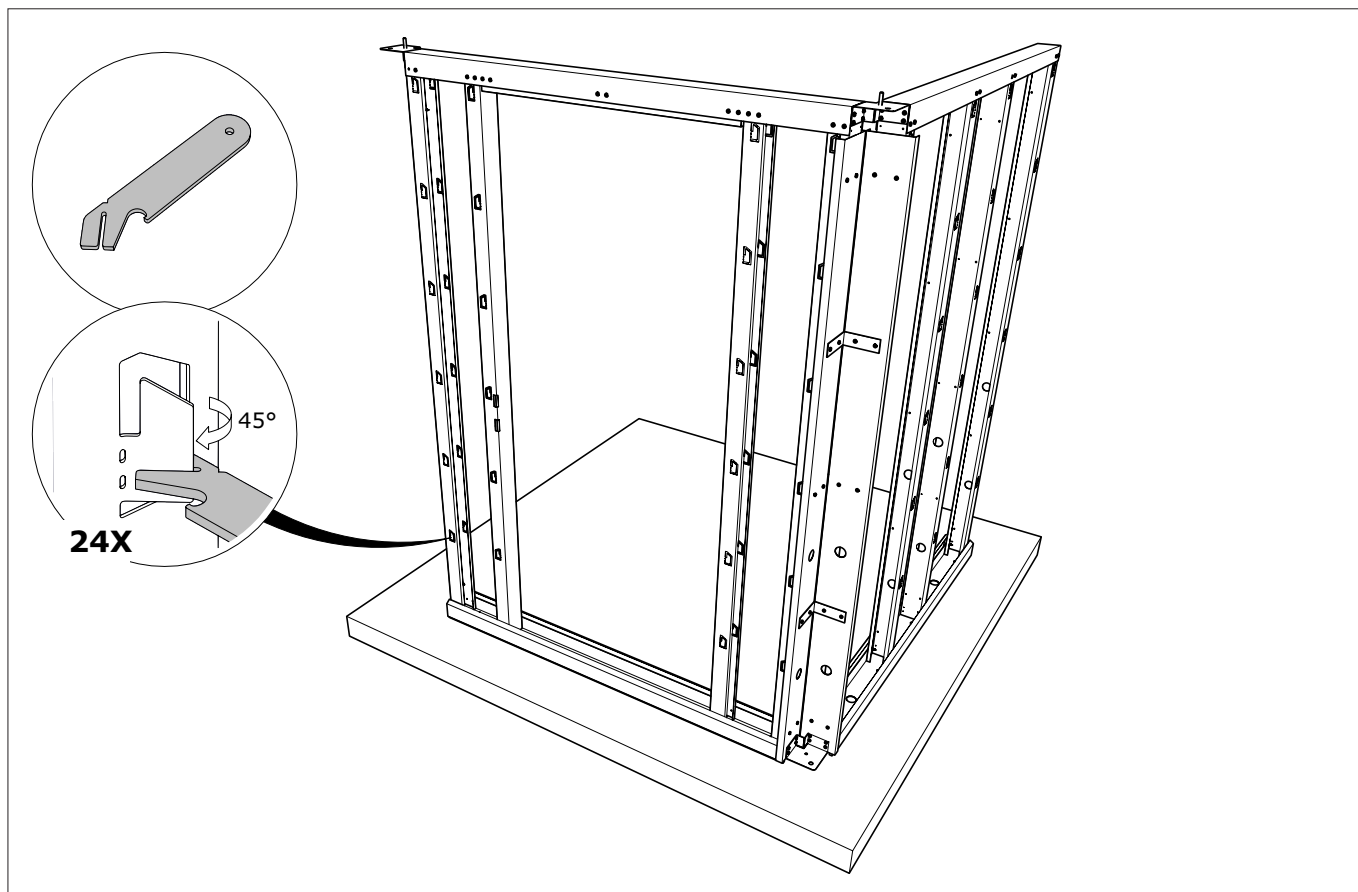

A + B Paroi / Wand / Wall / Wand

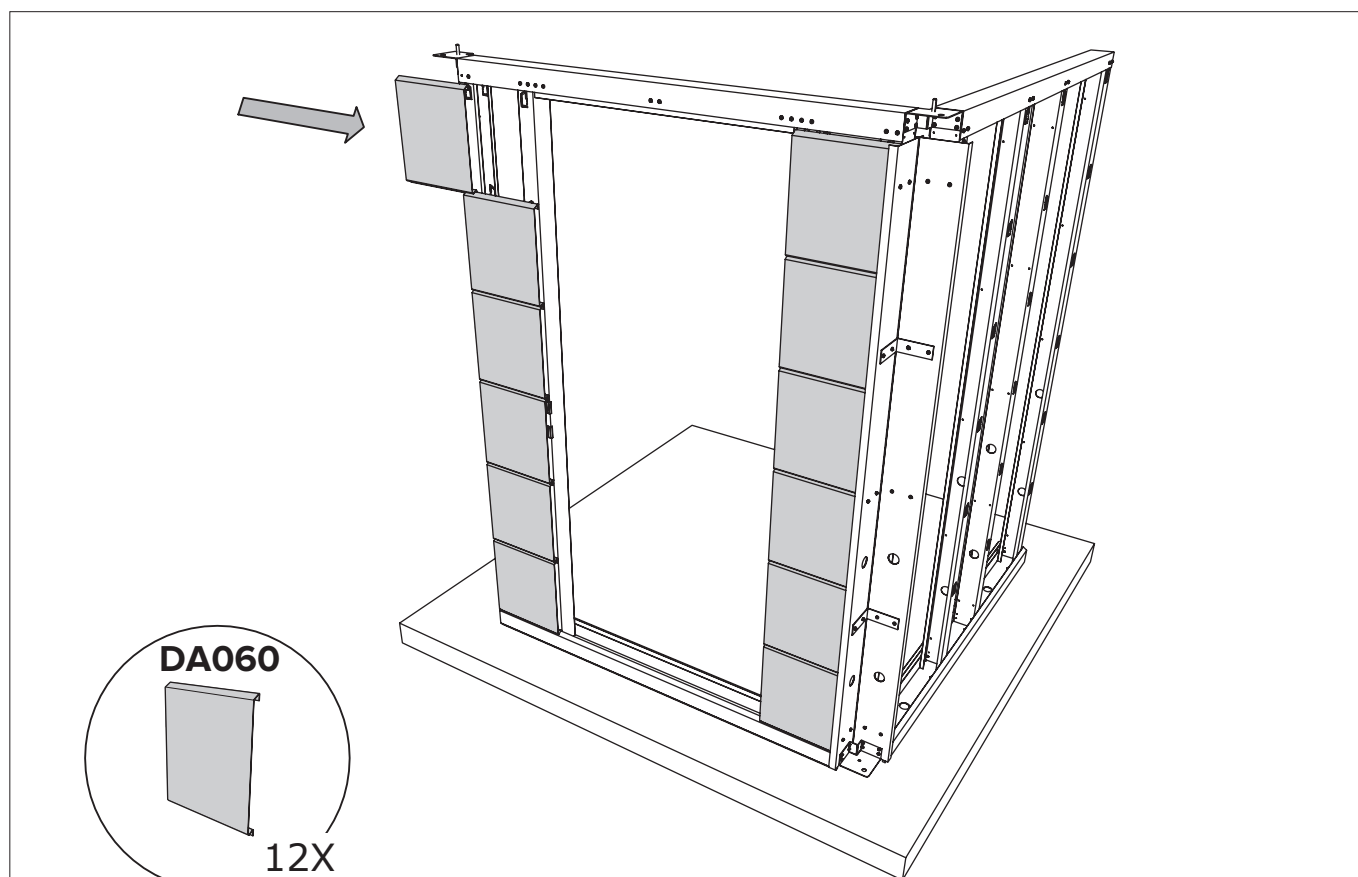

A + B Paroi / Wand / Wall / Wand

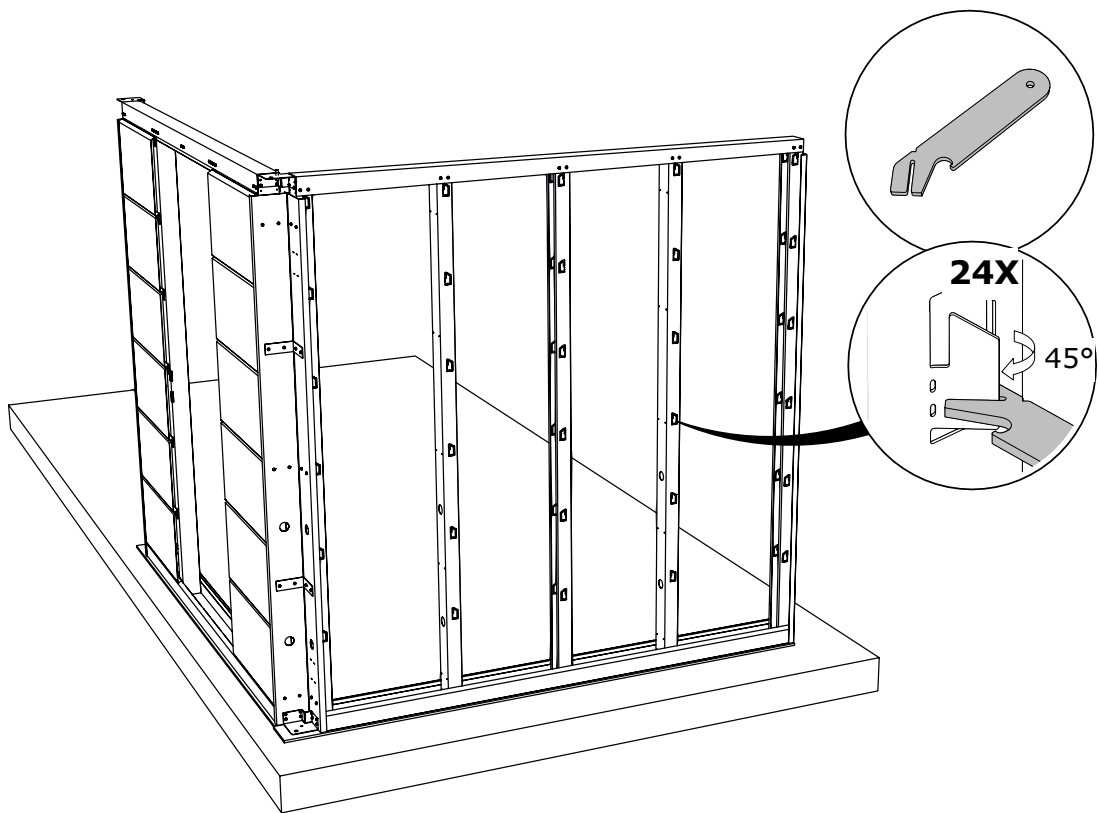

A + B Paroi / Wand / Wall / Wand

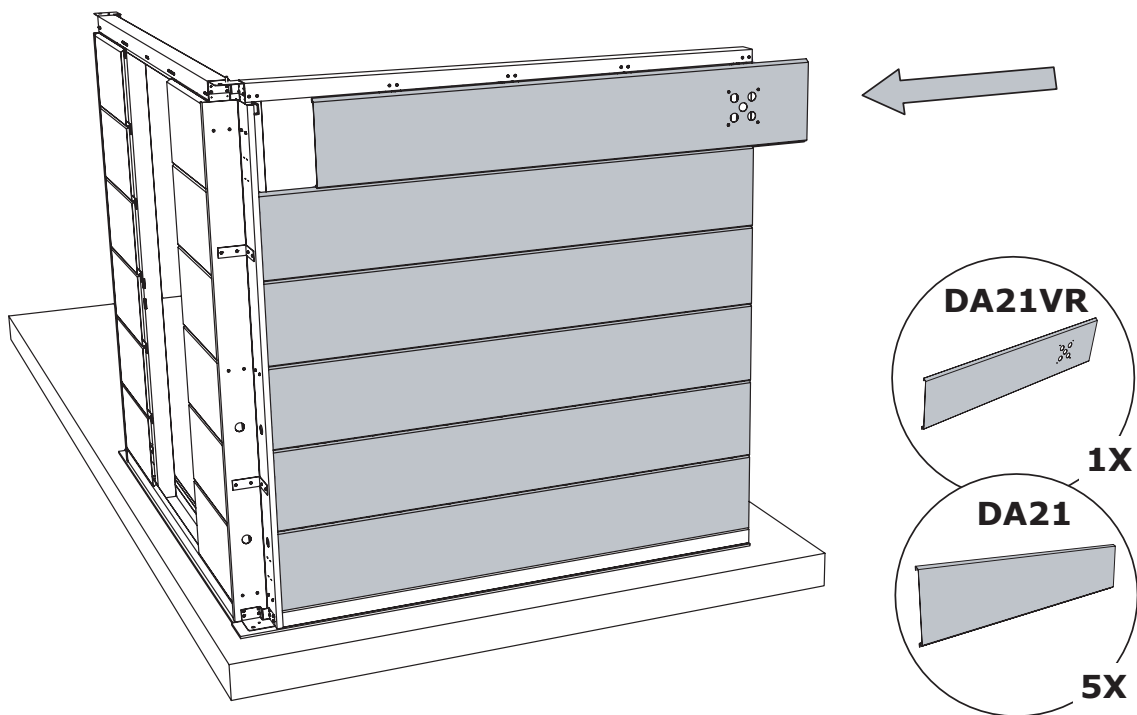

A + B Paroi / Wand / Wall / Wand

revêtement intérieur
 binnenbekleding
 interior lining
 Innenverkleidung

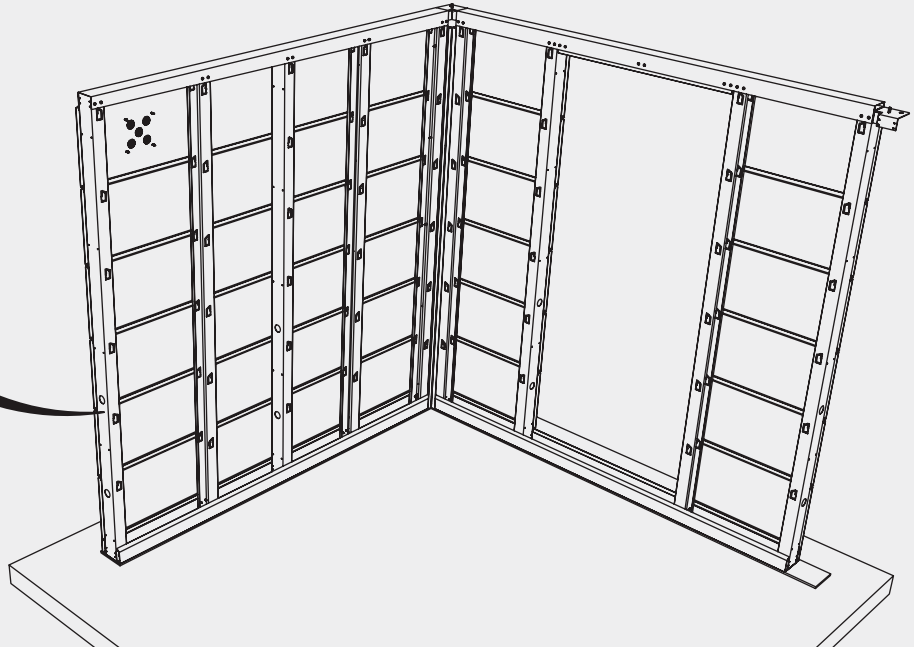
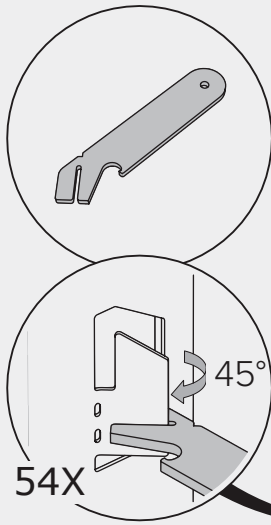

A + B Paroi / Wand / Wall / Wand

Option / Optie / Option / Option

revêtement intérieur
 binnenbekleding
 interior lining
 Innenverkleidung

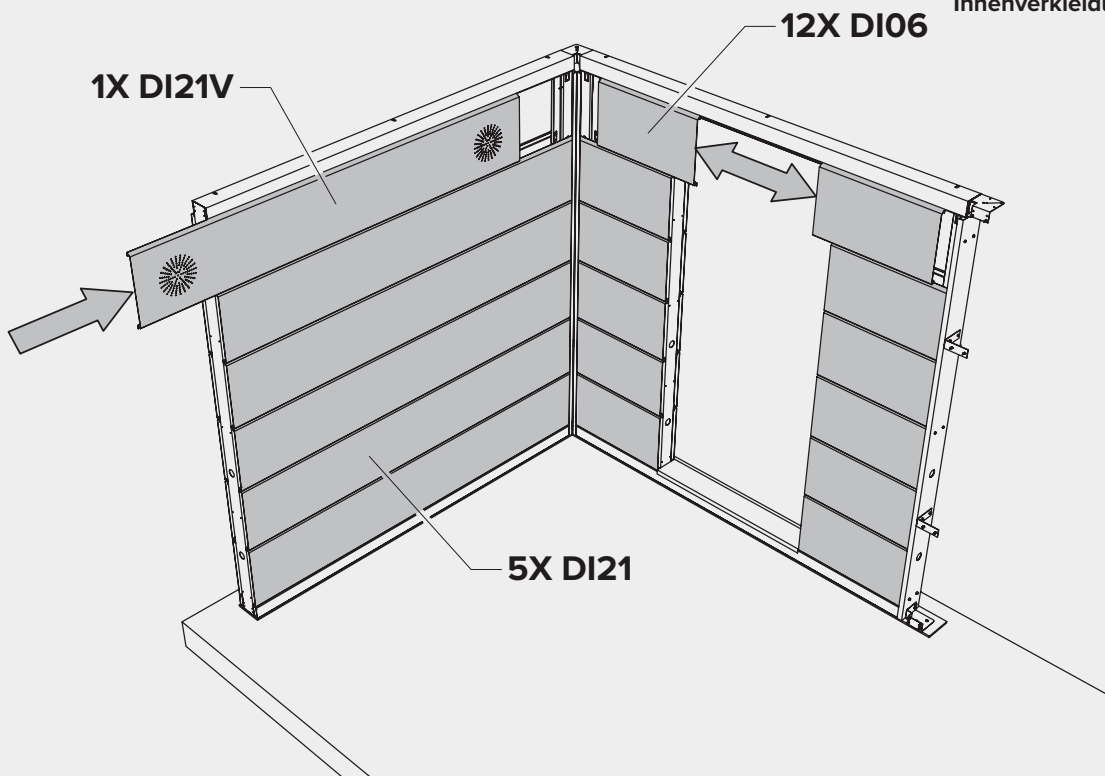

A + B Paroi / Wand / Wall / Wand

Option / Optie / Option / Option

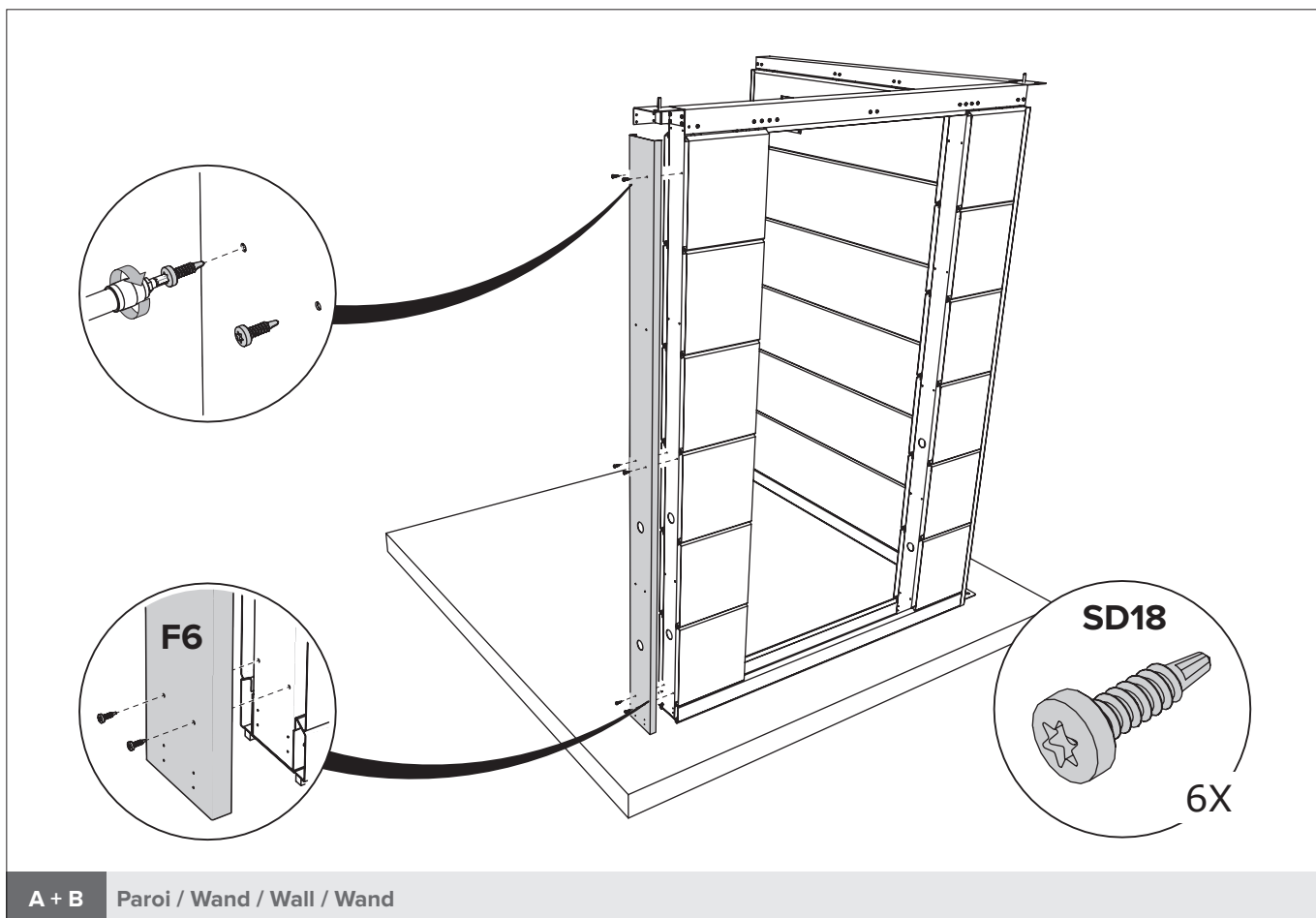
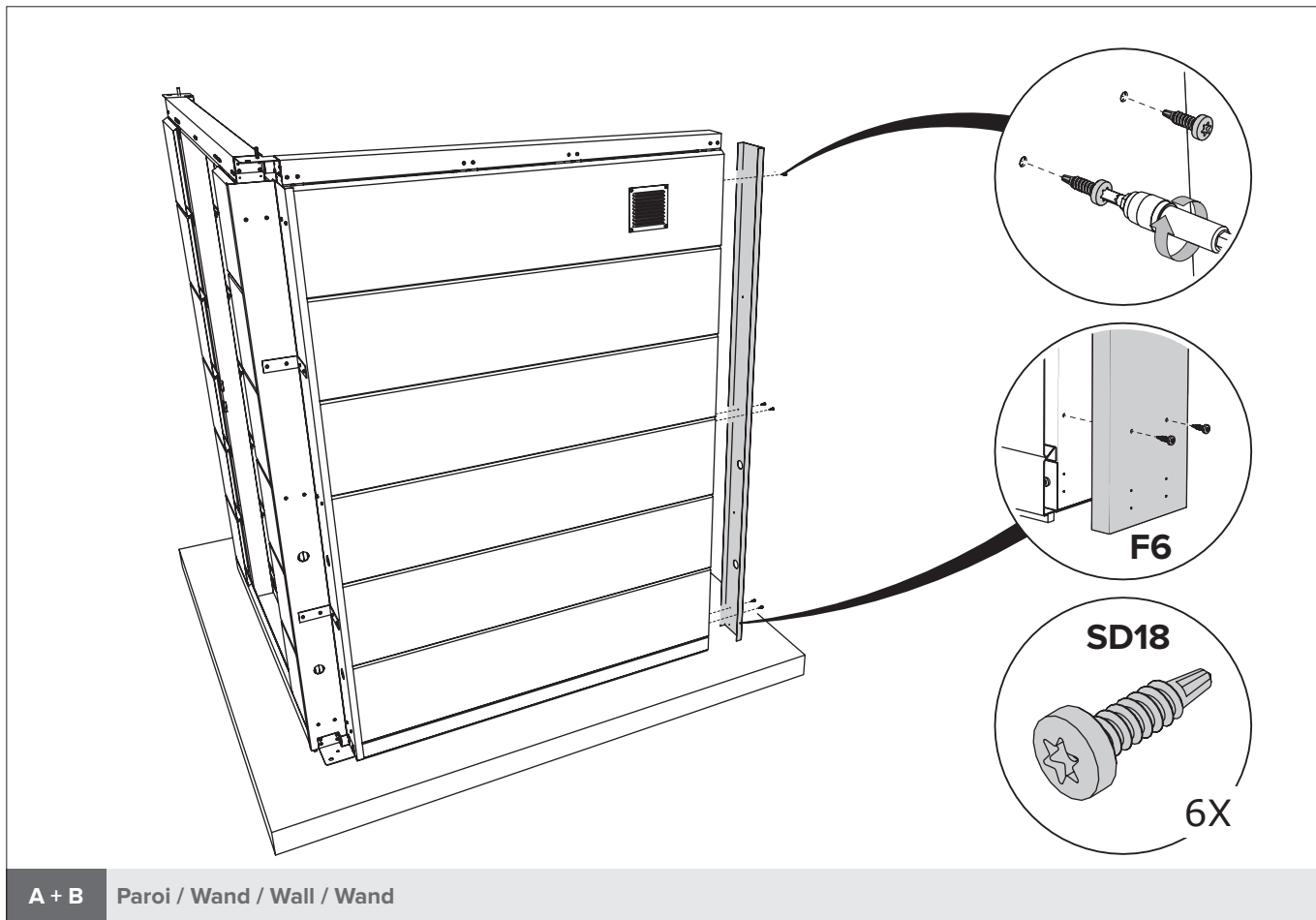

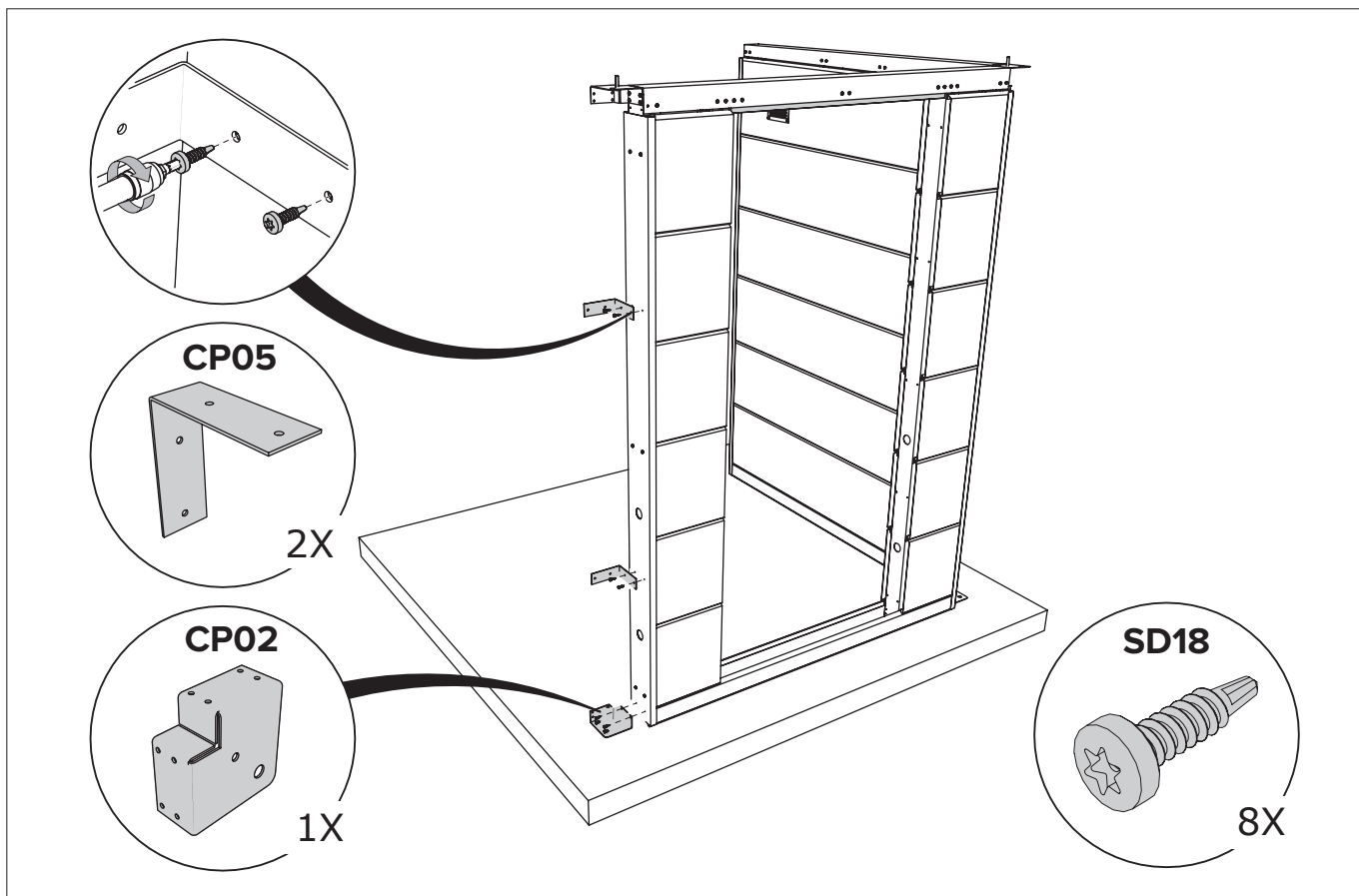

A + B Paroi / Wand / Wall / Wand

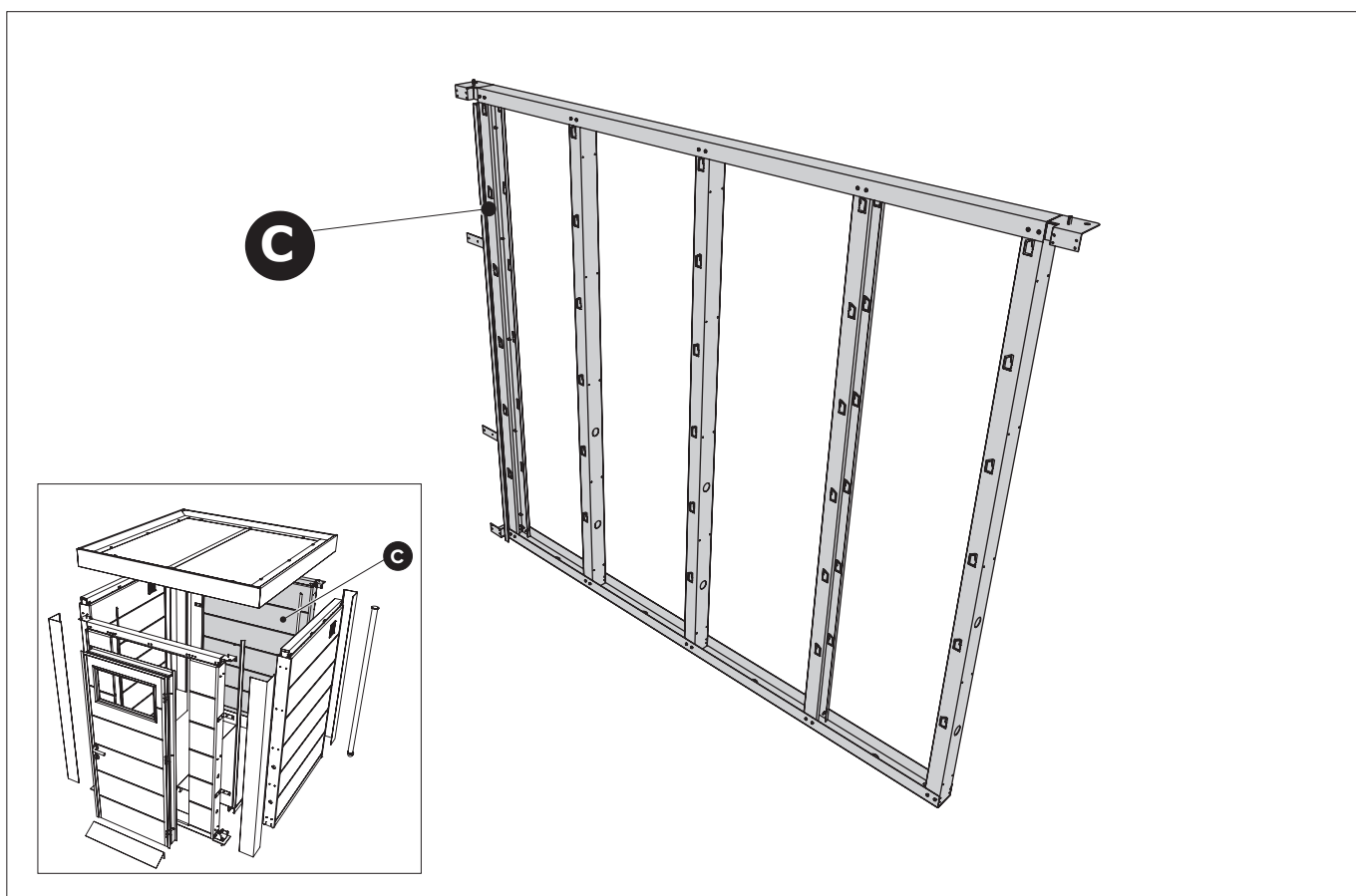

C Paroi / Wand / Wall / Wand

Le principe de la construction du mur, voir pages 8 à 11 (POW).
 Het principe van de opbouw van de wand, zie pagina 8 tot en met 11 (POW).
 The principle of building the wall, see pages 8 through 11 (POW).
 Aufbau der Wandelemente Sie auf den Seiten 8 bis 11 (POW).

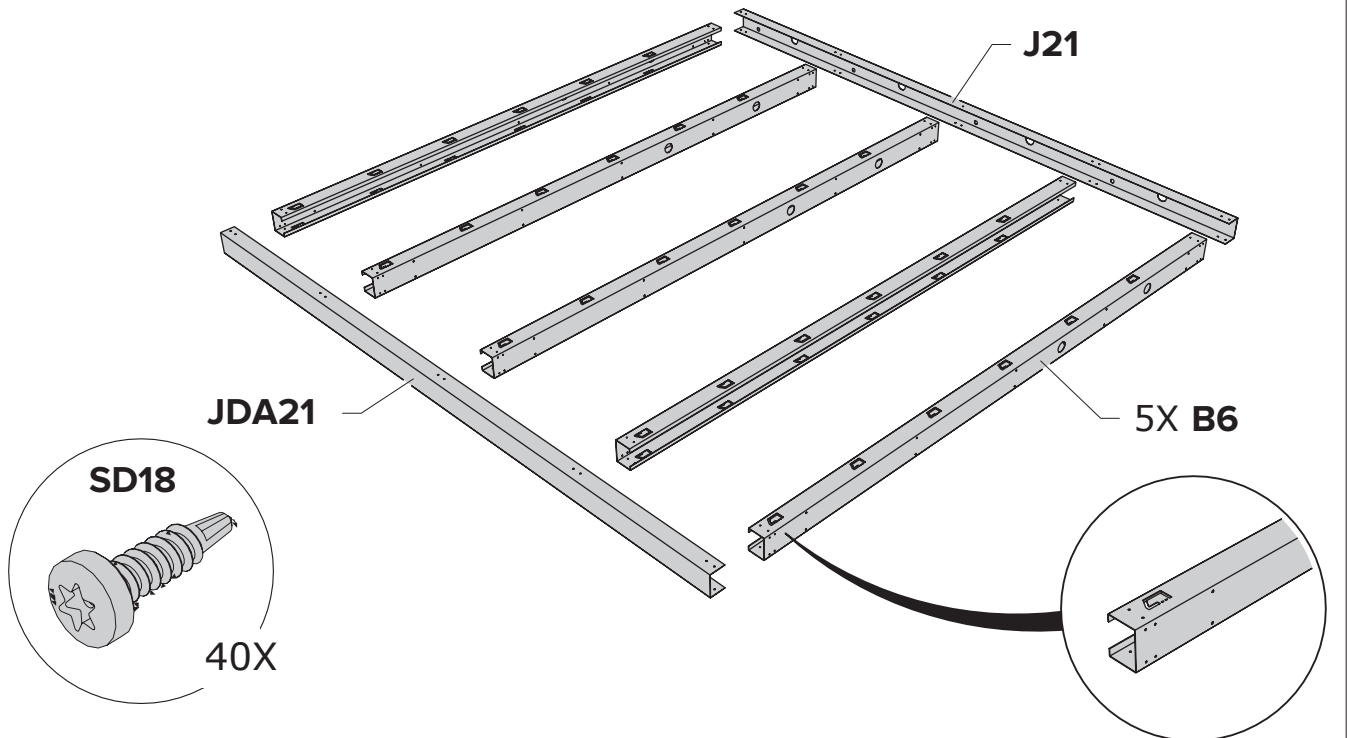

C Paroi / Wand / Wall / Wand

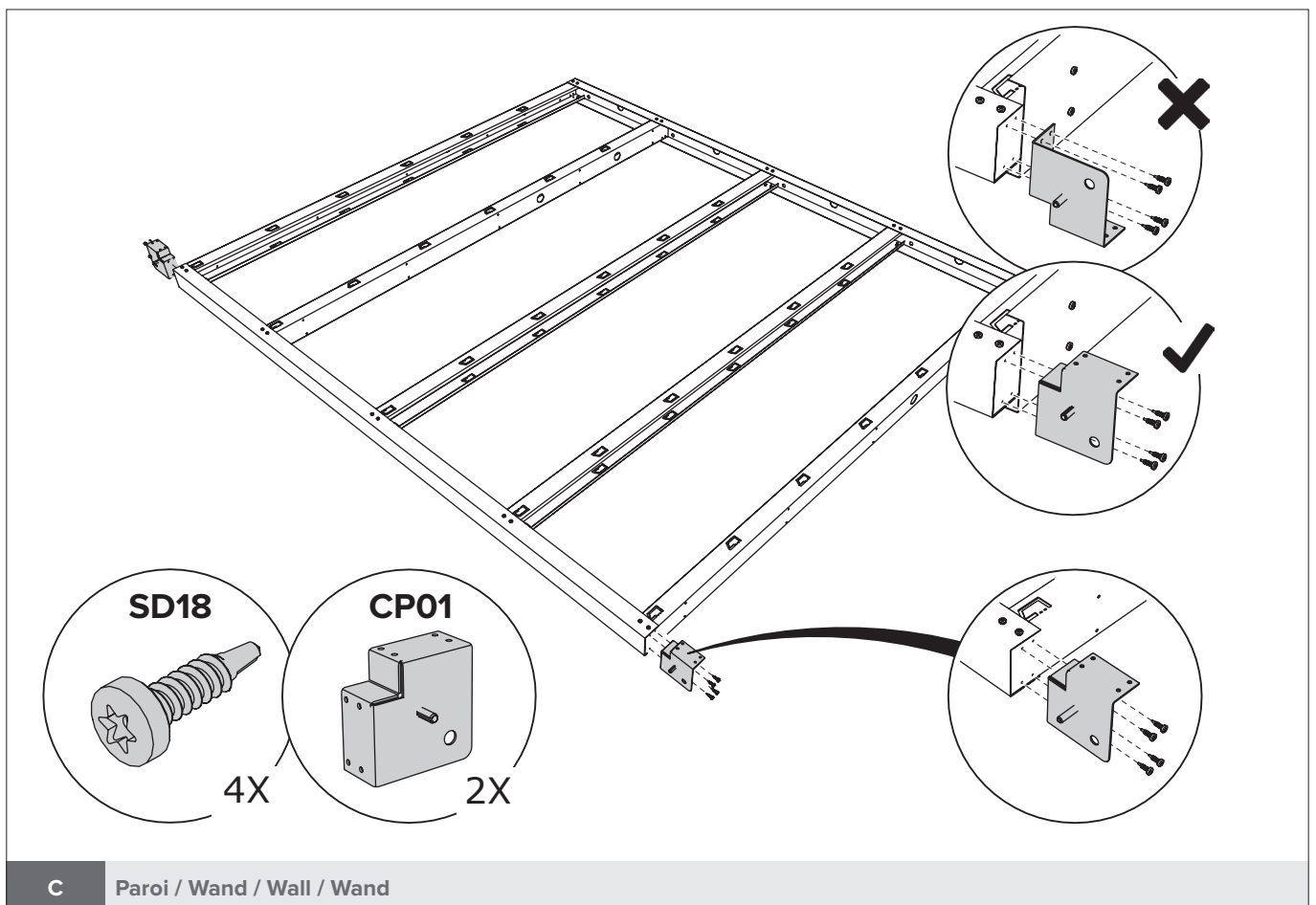

C Paroi / Wand / Wall / Wand

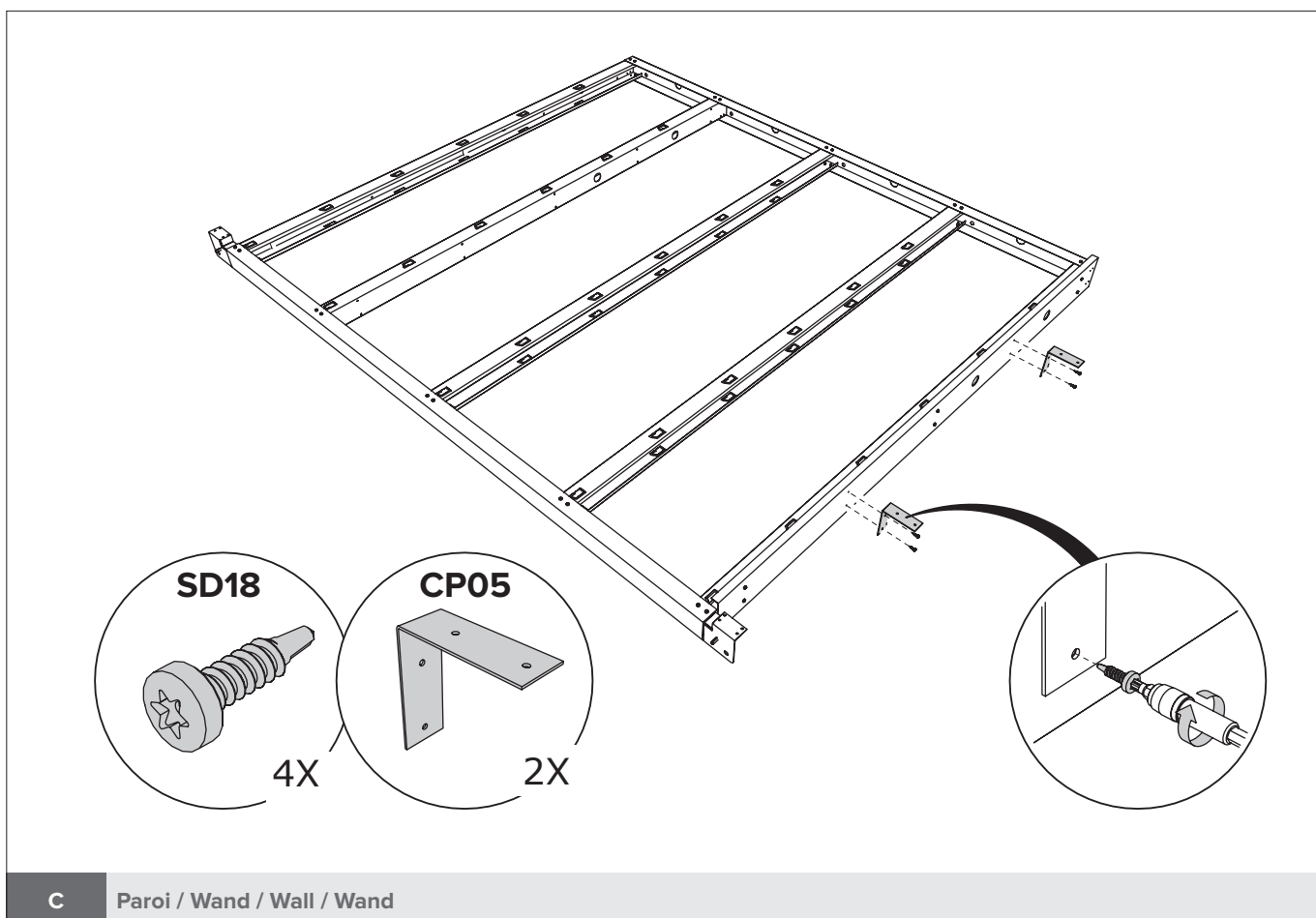
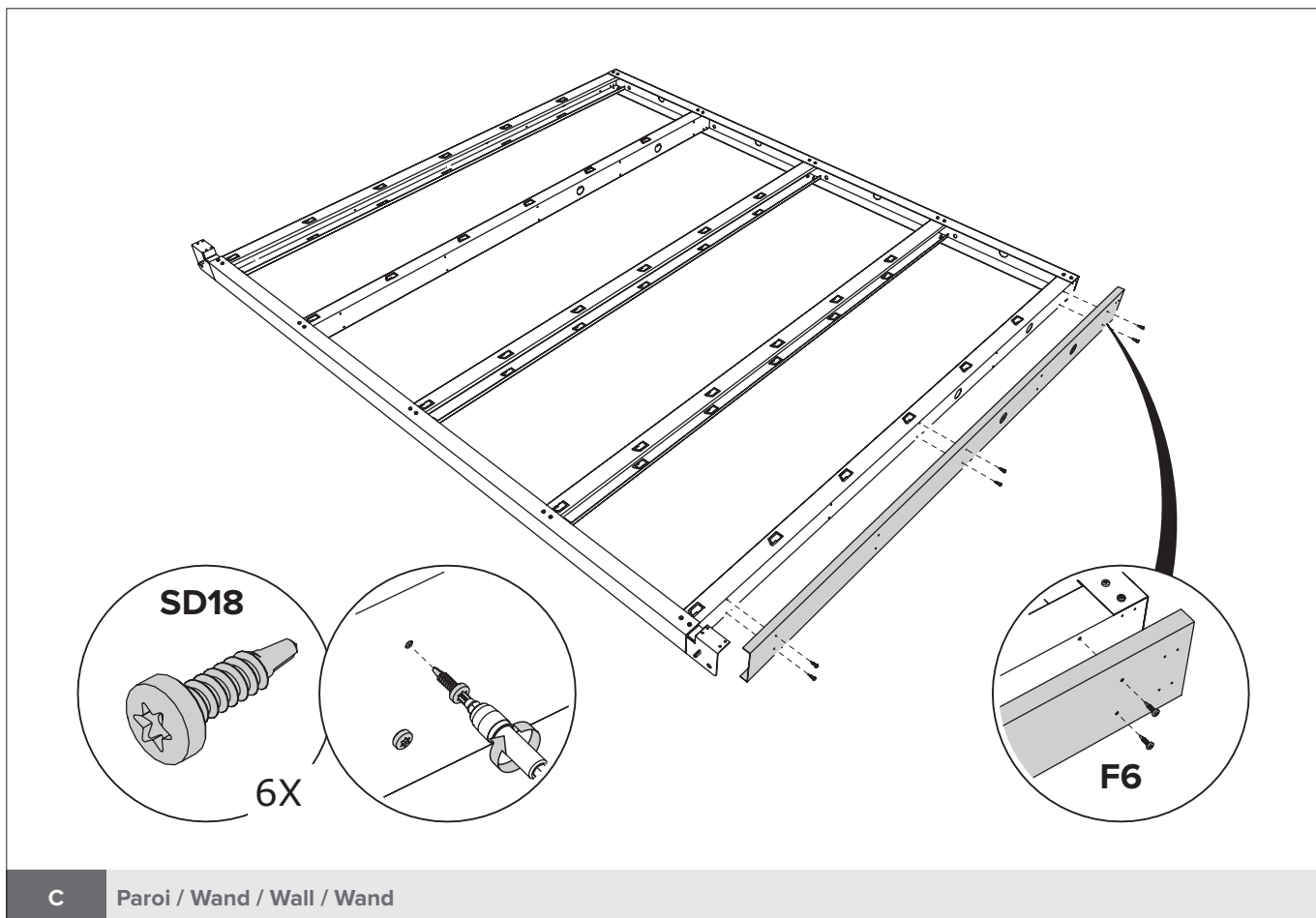

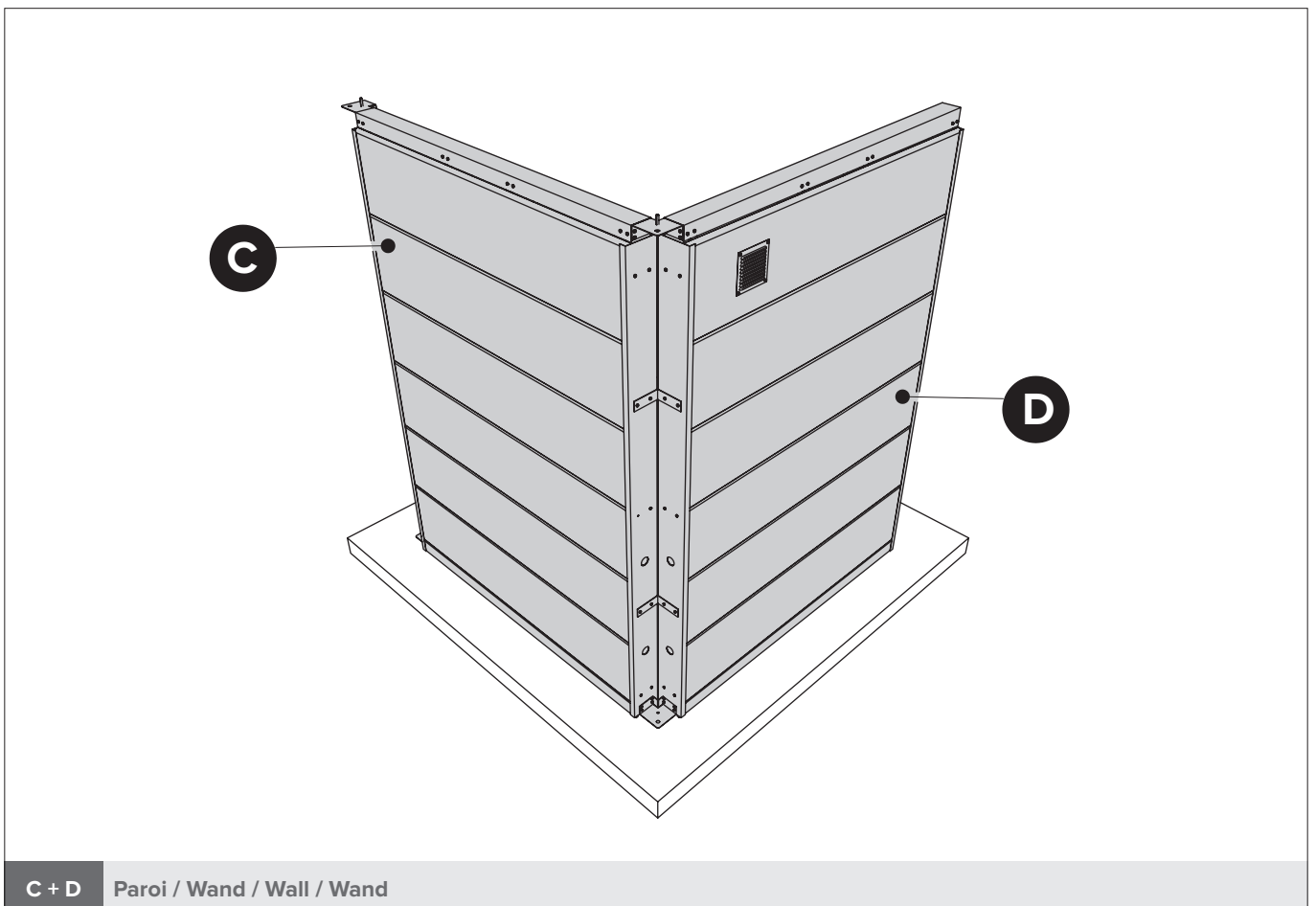
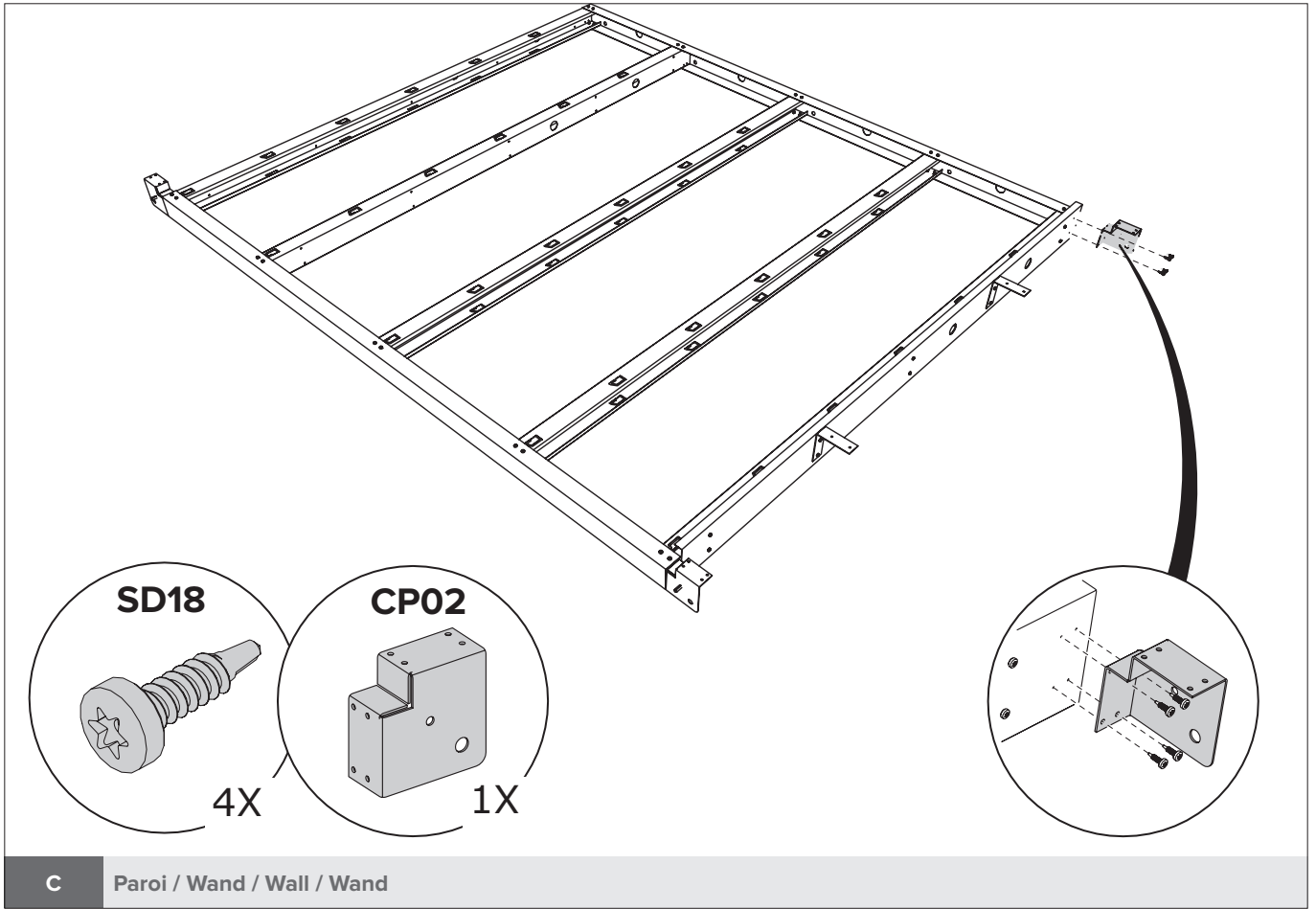

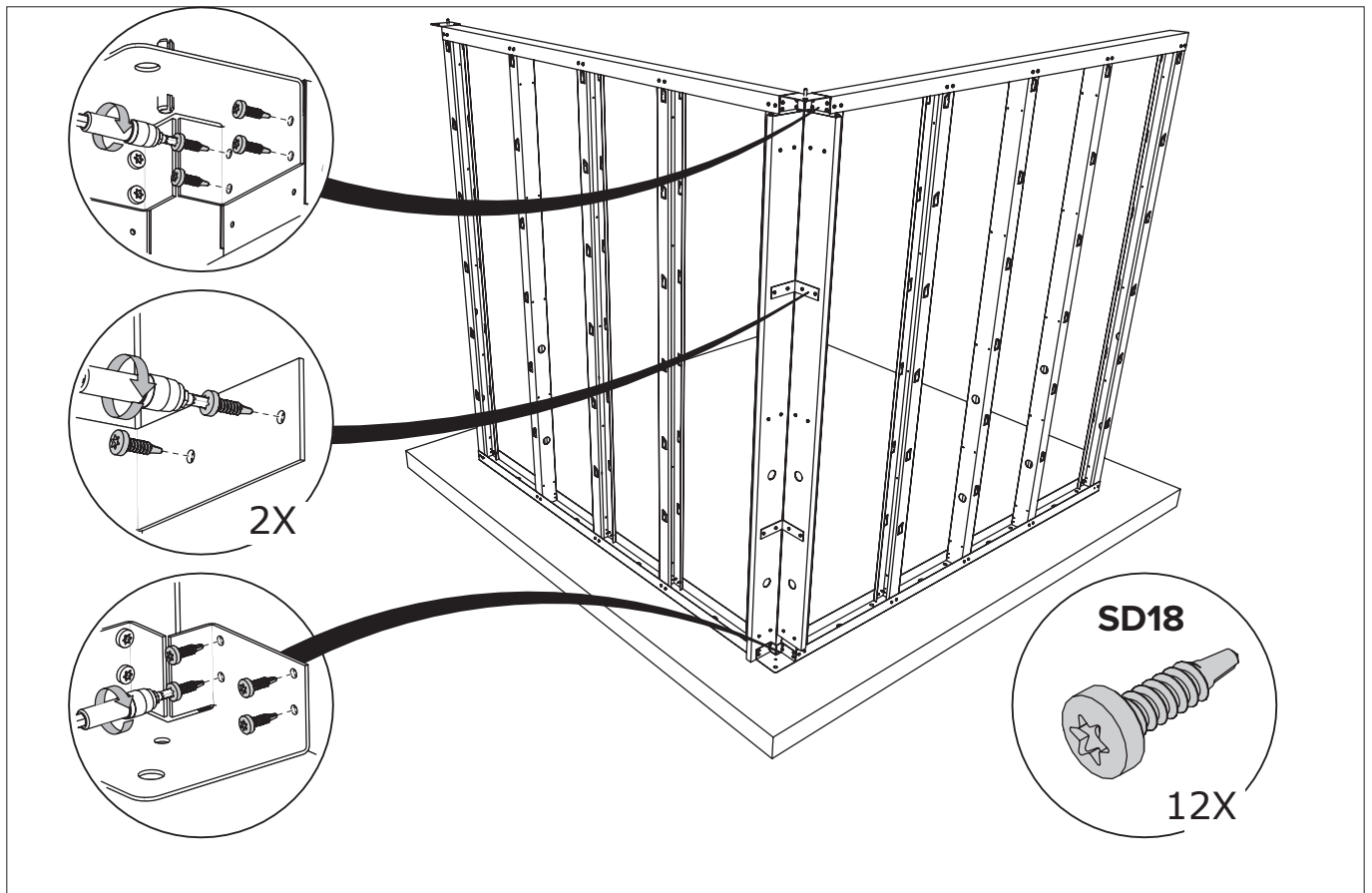

C + D Paroi / Wand / Wall / Wand

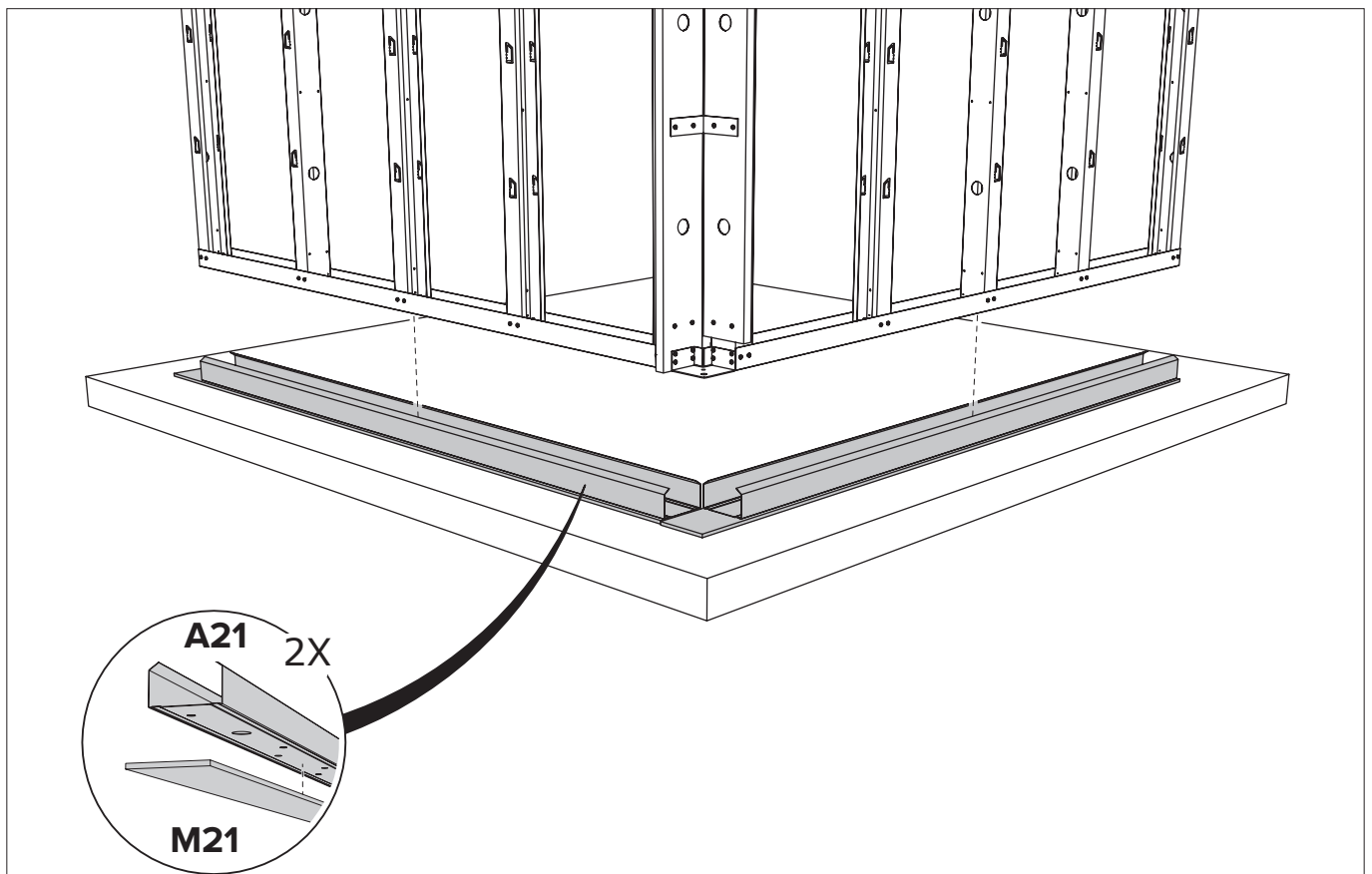

C + D Paroi / Wand / Wall / Wand

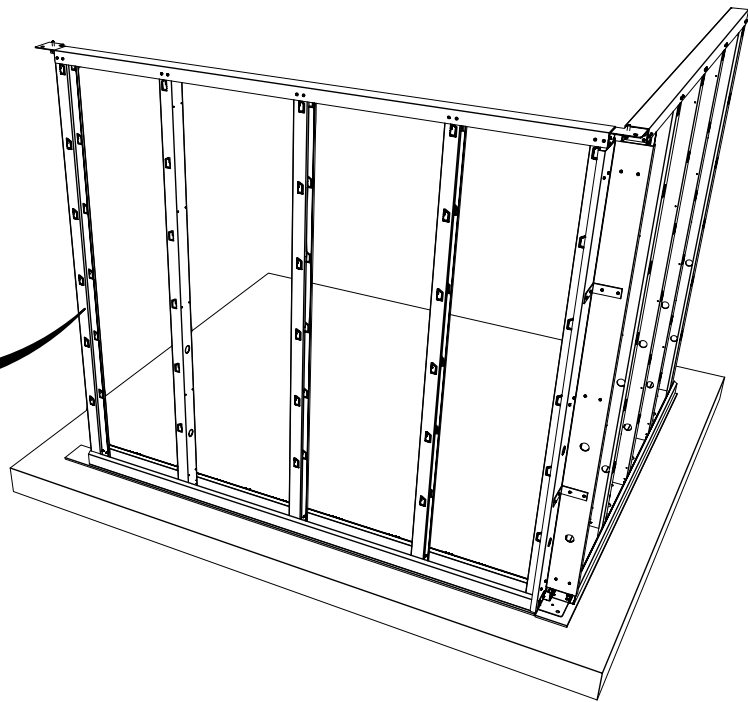
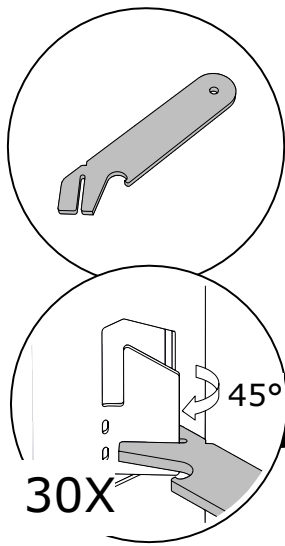

C + D Paroi / Wand / Wall / Wand

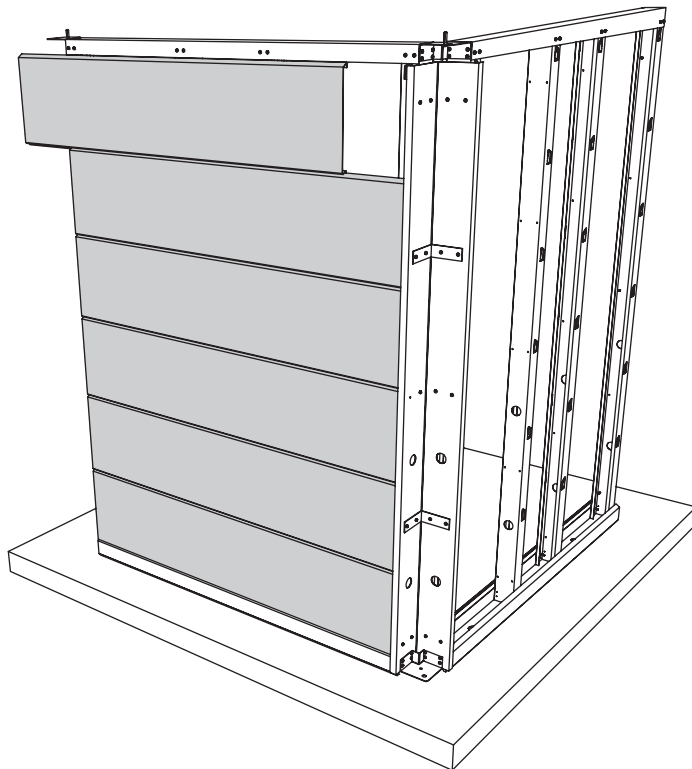
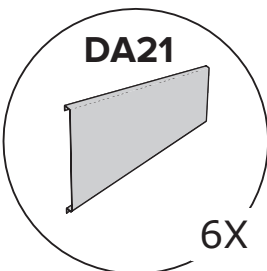

C + D Paroi / Wand / Wall / Wand

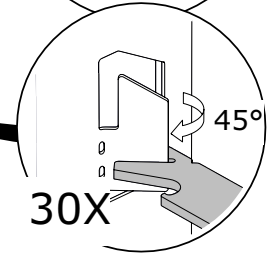
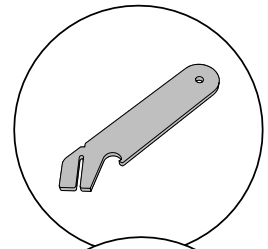
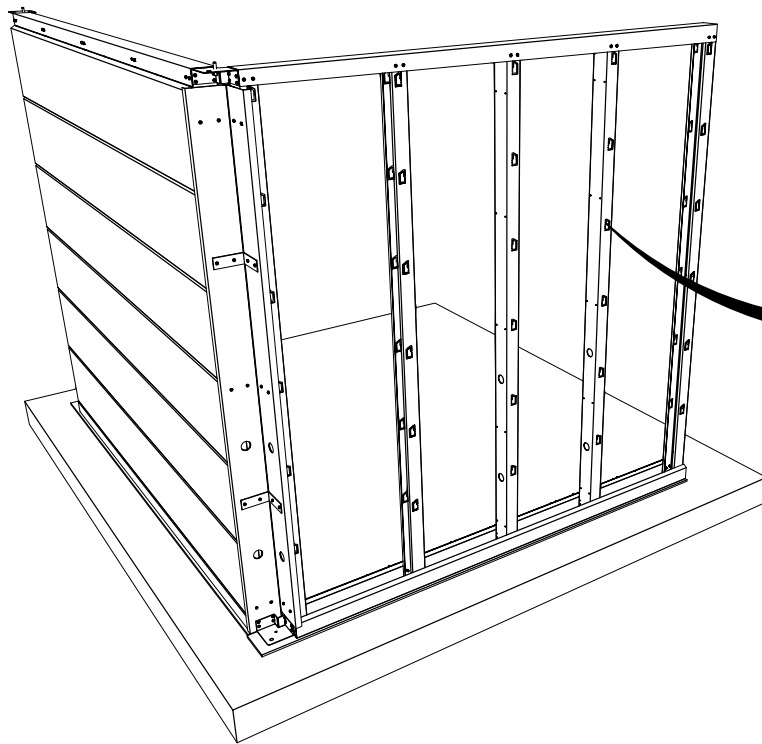

C + D Paroi / Wand / Wall / Wand

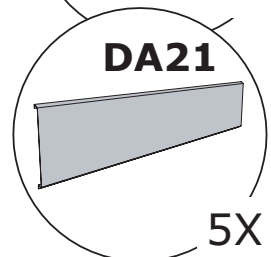
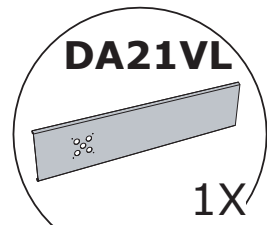
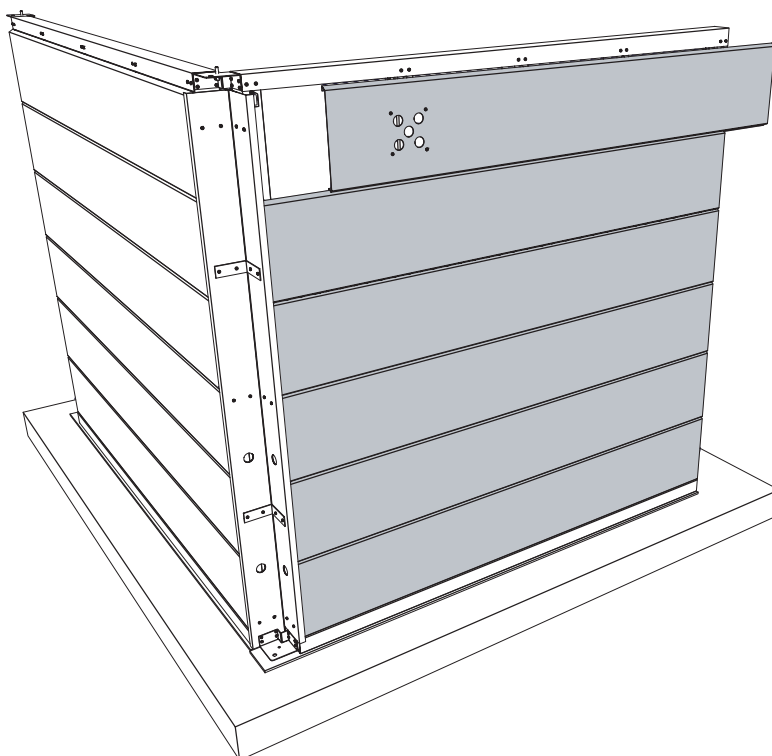

C + D Paroi / Wand / Wall / Wand

revêtement intérieur
 binnenbekleding
 interior lining
 Innenverkleidung

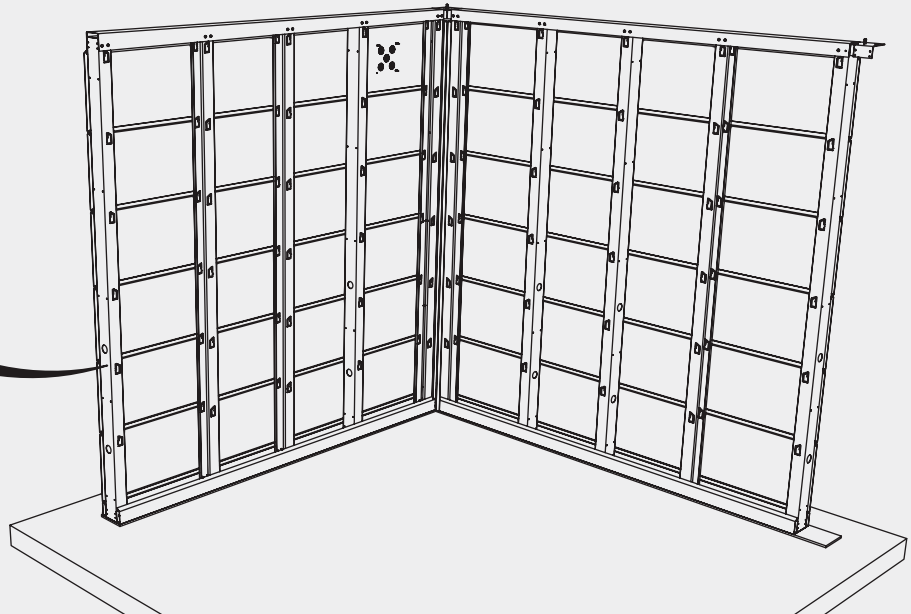
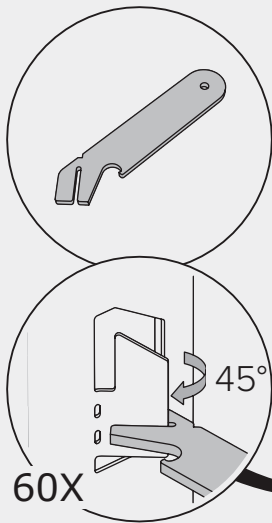

C + D Paroi / Wand / Wall / Wand

Option / Optie / Option / Option

revêtement intérieur et plaque perforée
 binnenbekleding en geperforeerde plaat
 interior lining and perforated plate
 Innenverkleidung und perforierte Platte

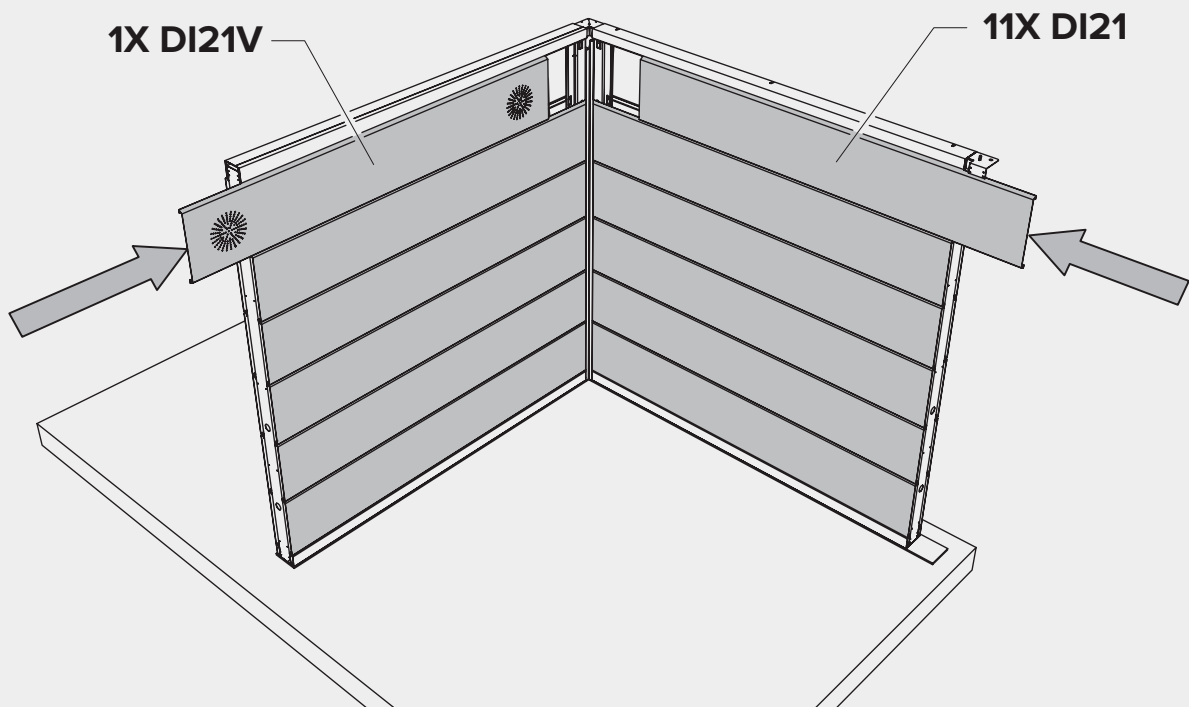

C + D Paroi / Wand / Wall / Wand

Option / Optie / Option / Option

revêtement intérieur et plaque perforée
binnenbekleding en geperforeerde plaat
interior lining and perforated plate
Innenverkleidung und perforierte Platte

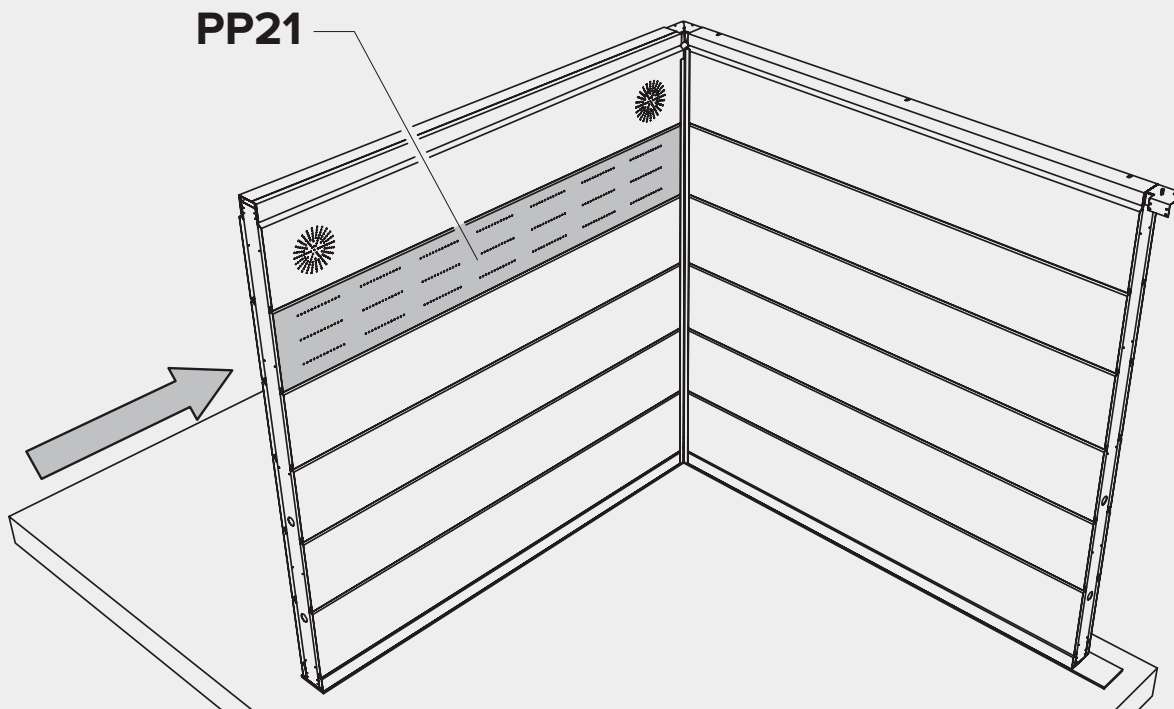

C+D Paroi / Wand / Wall / Wand

Option / Optie / Option / Option

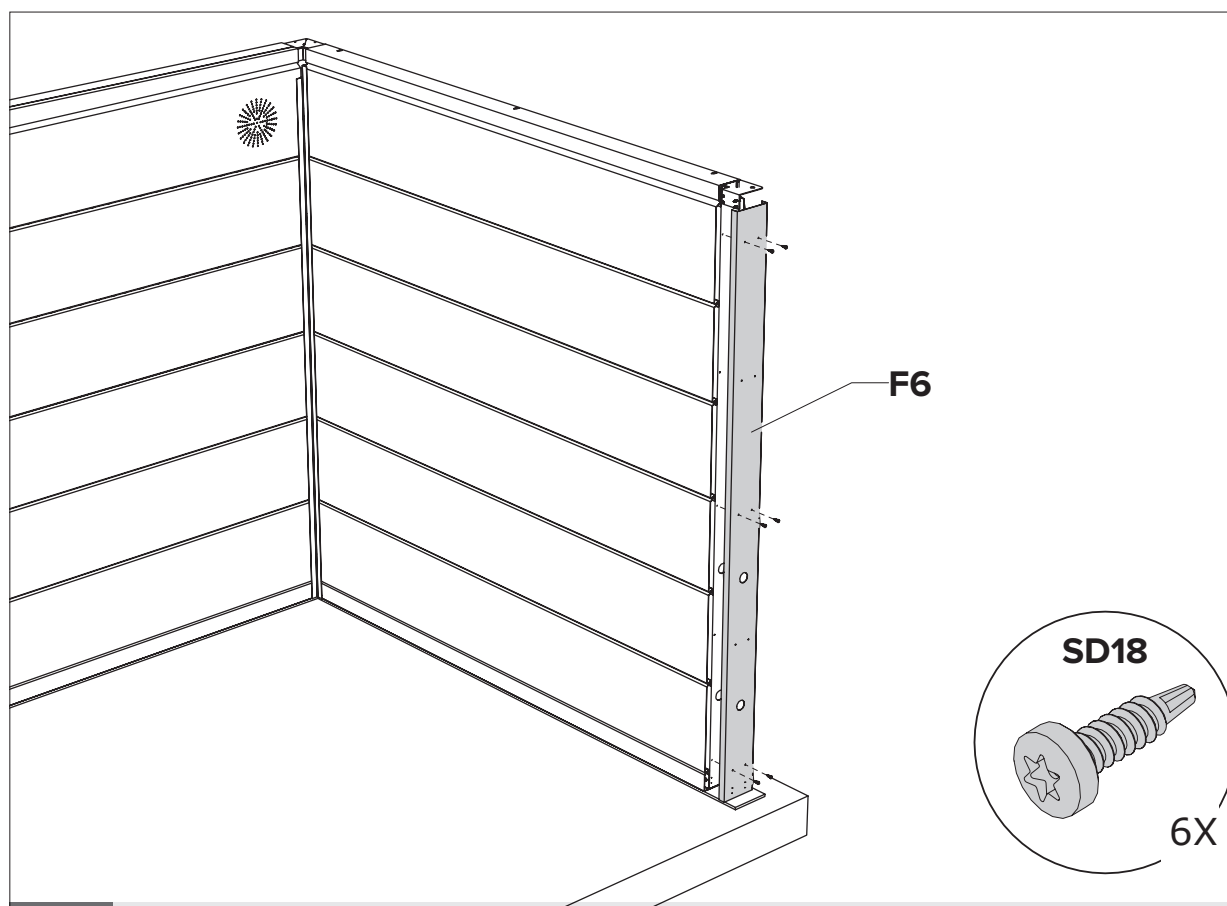

C+D Paroi / Wand / Wall / Wand

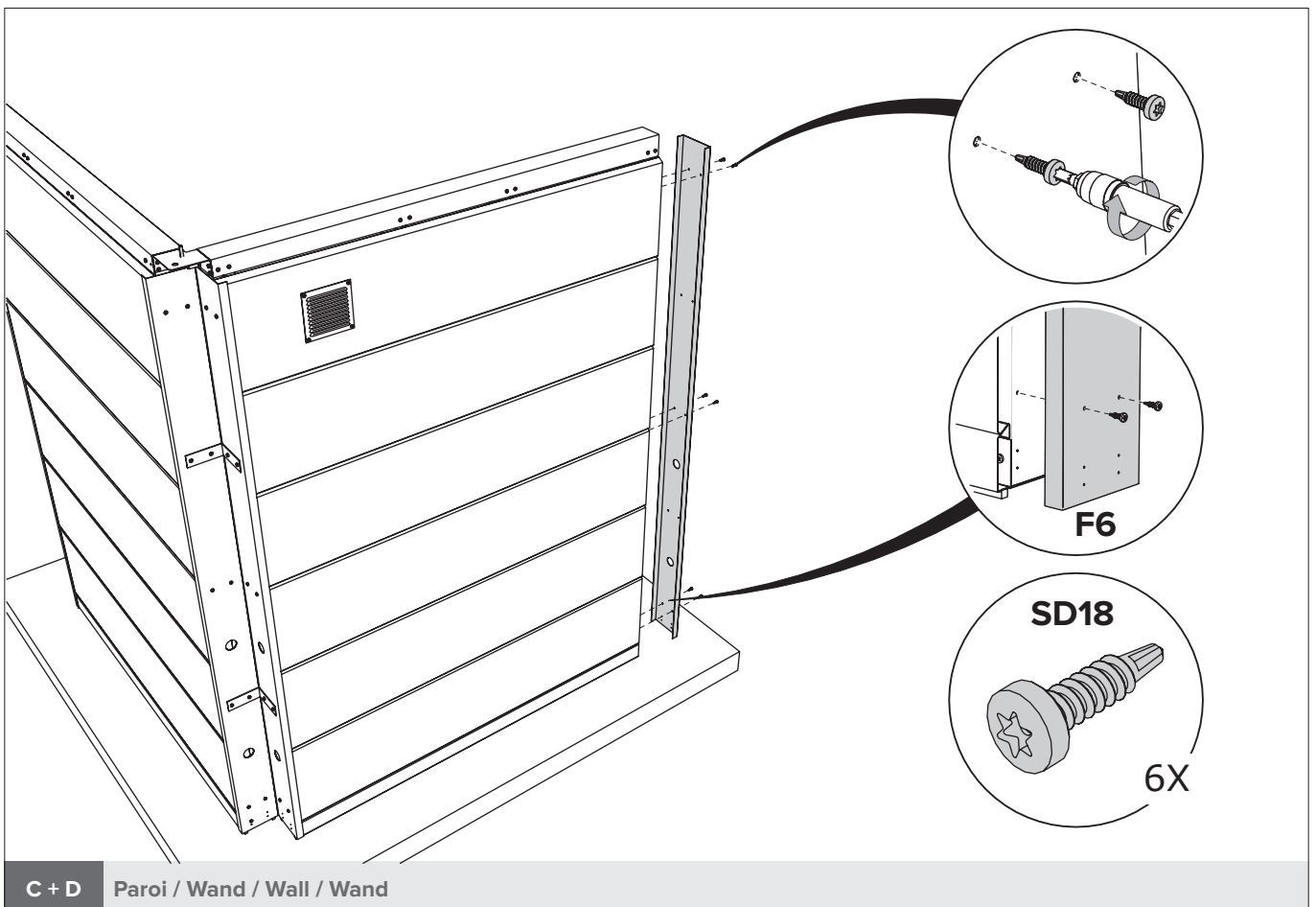
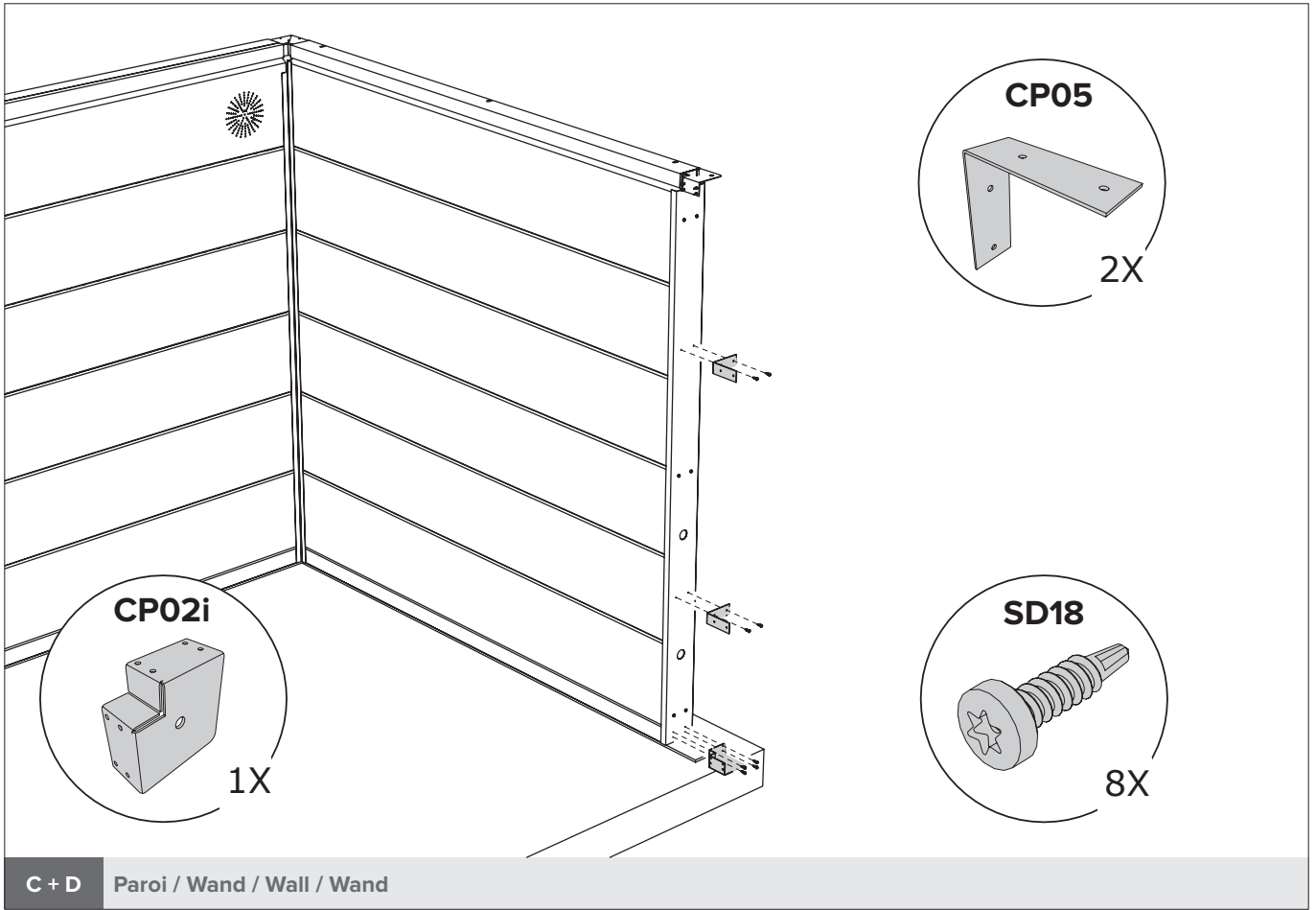

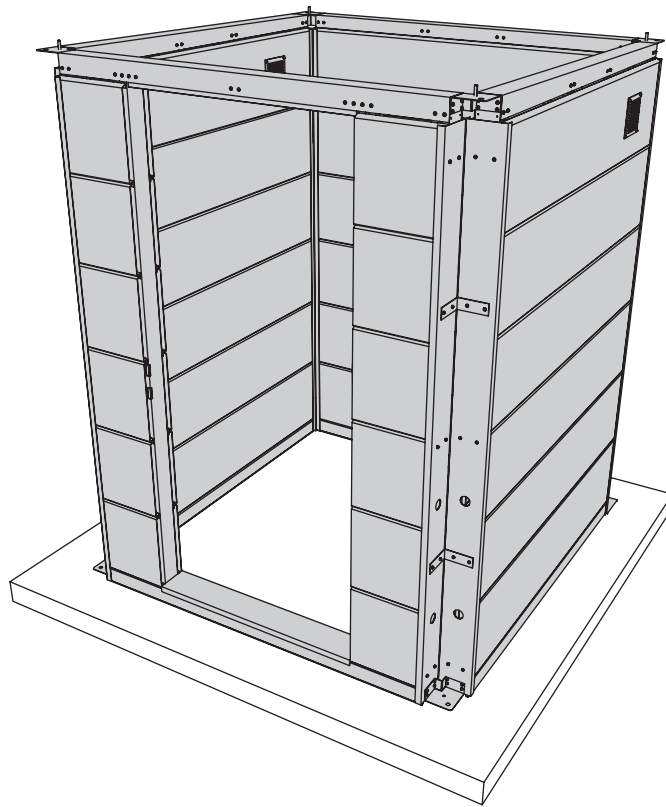

A + B + C + D Paroi / Wand / Wall / Wand

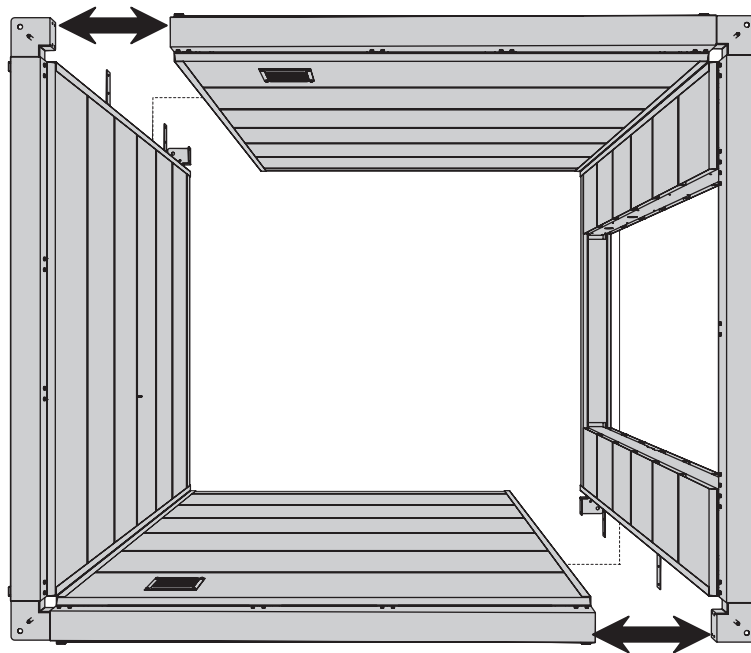

A + B + C + D Paroi / Wand / Wall / Wand

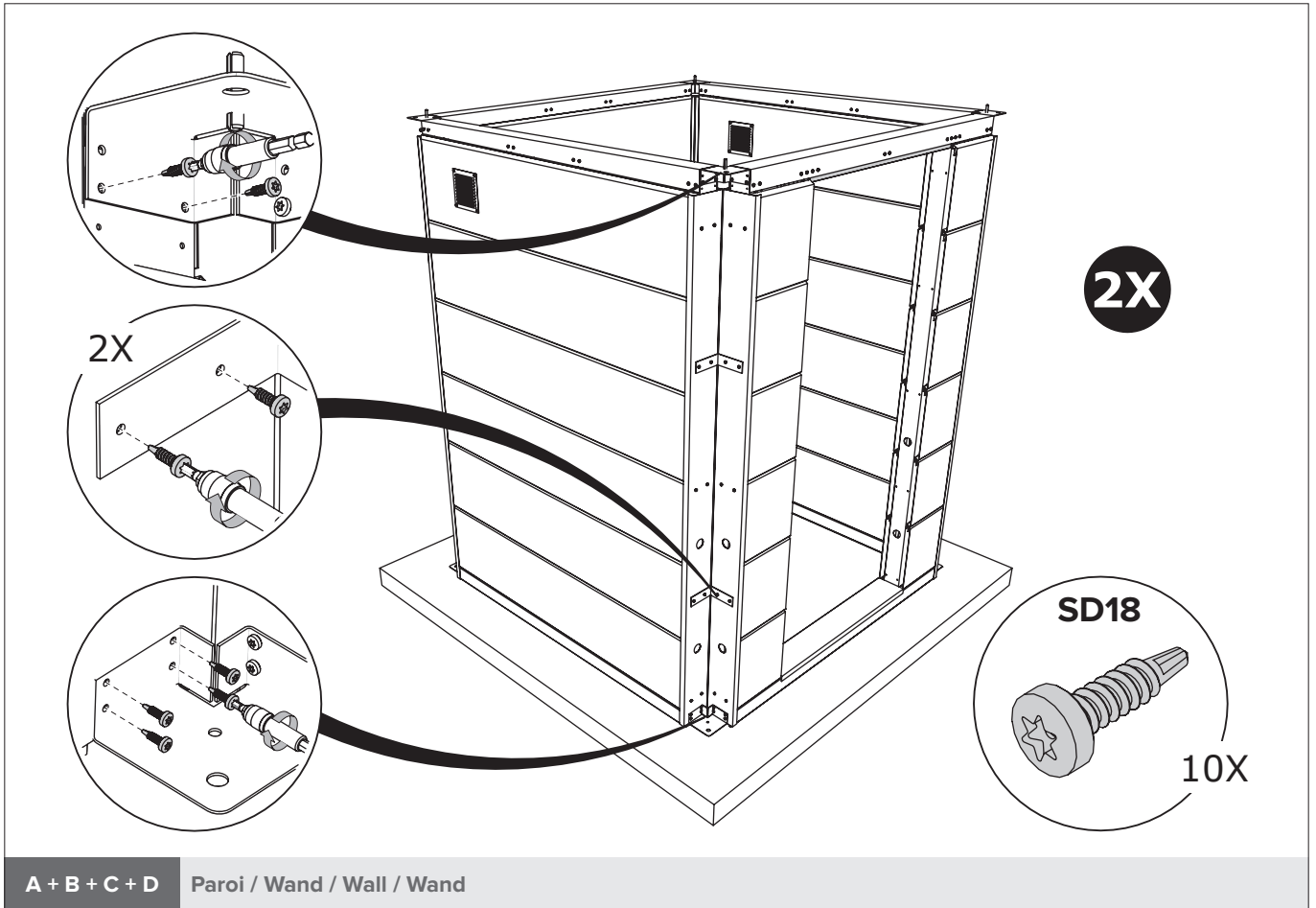

Installez la porte maintenant, voir la pièce jointe.

Installeer deur nu, zie bijlage.

Install door now, see attachment.

Tür jetzt montieren, siehe Anhang.

Installez la porte maintenant, voir la pièce jointe.

Installeer deur nu, zie bijlage.

Install door now, see attachment.

Tür jetzt montieren, siehe Anhang.

Porte / Deur / Door / Tür

revêtement intérieur
 binnenbekleding
 interior lining
 Innenverkleidung

IG = 2.090mm
 IK = 2.070mm

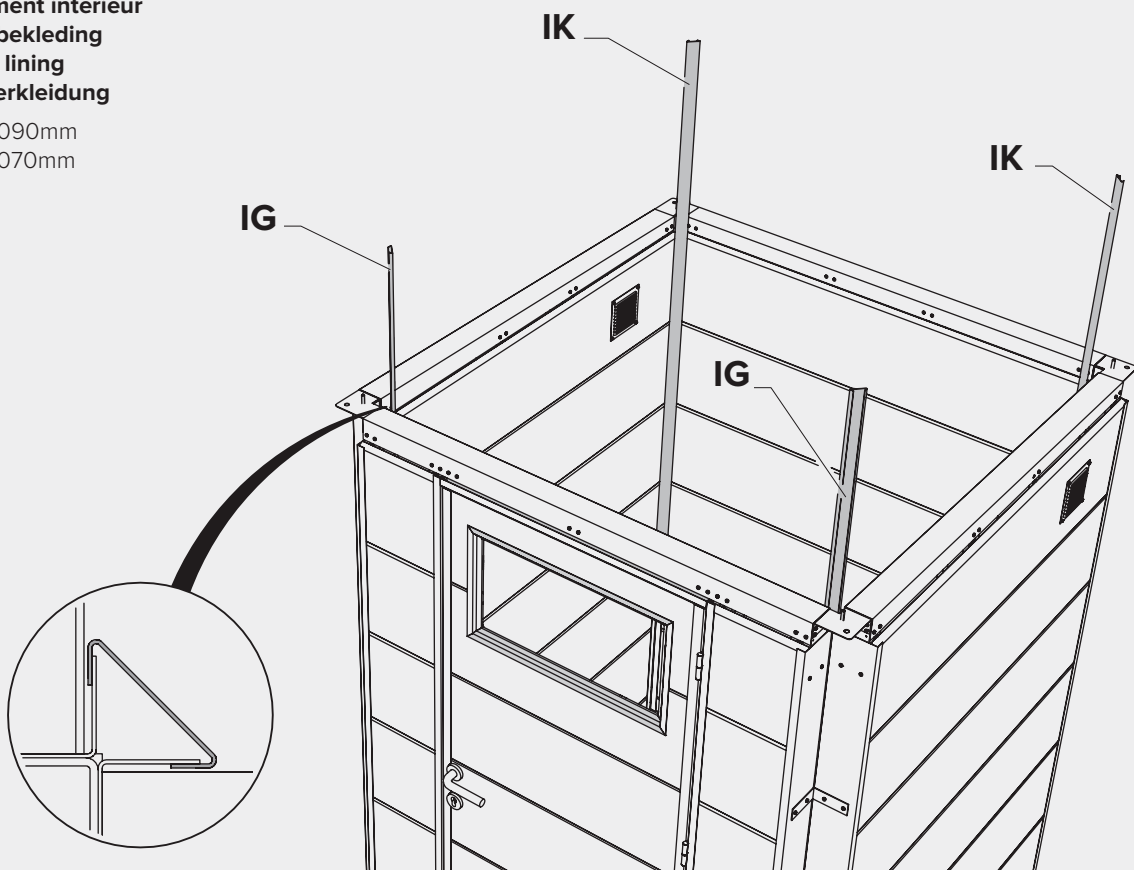

A + B + C + D Paroi / Wand / Wall / Wand

Option / Optie / Option / Option

revêtement intérieur
 binnenbekleding
 interior lining
 Innenverkleidung

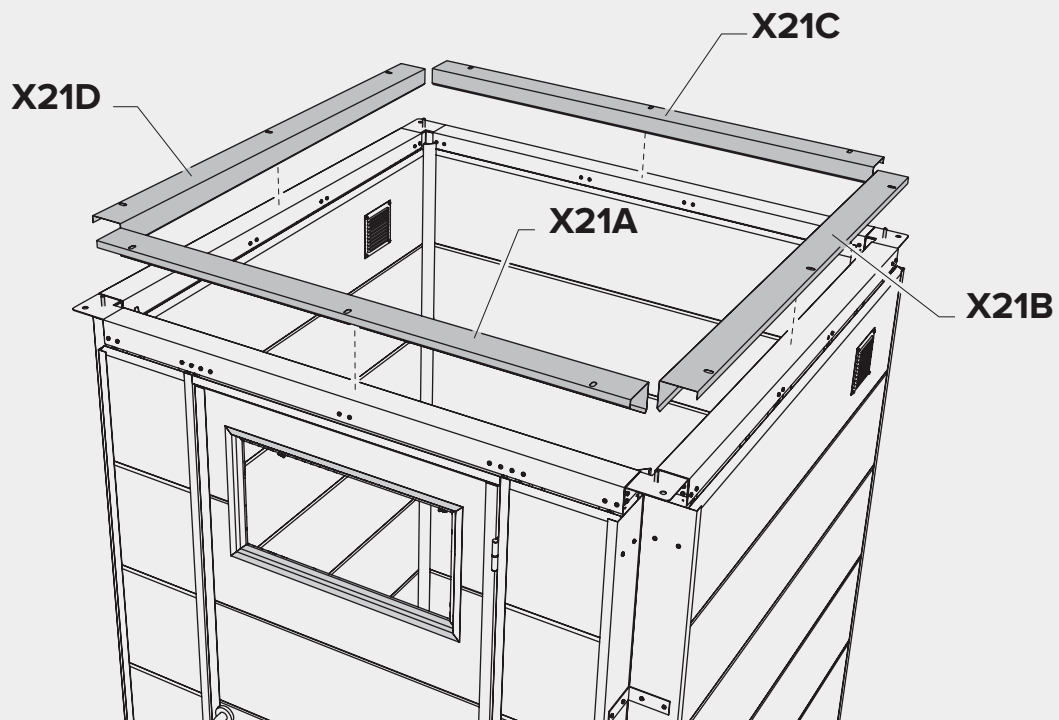

A + B + C + D Paroi / Wand / Wall / Wand

Option / Optie / Option / Option

revêtement intérieur
 binnenbekleding
 interior lining
 Innenverkleidung

IG = 2.090mm
 IK = 2.070mm

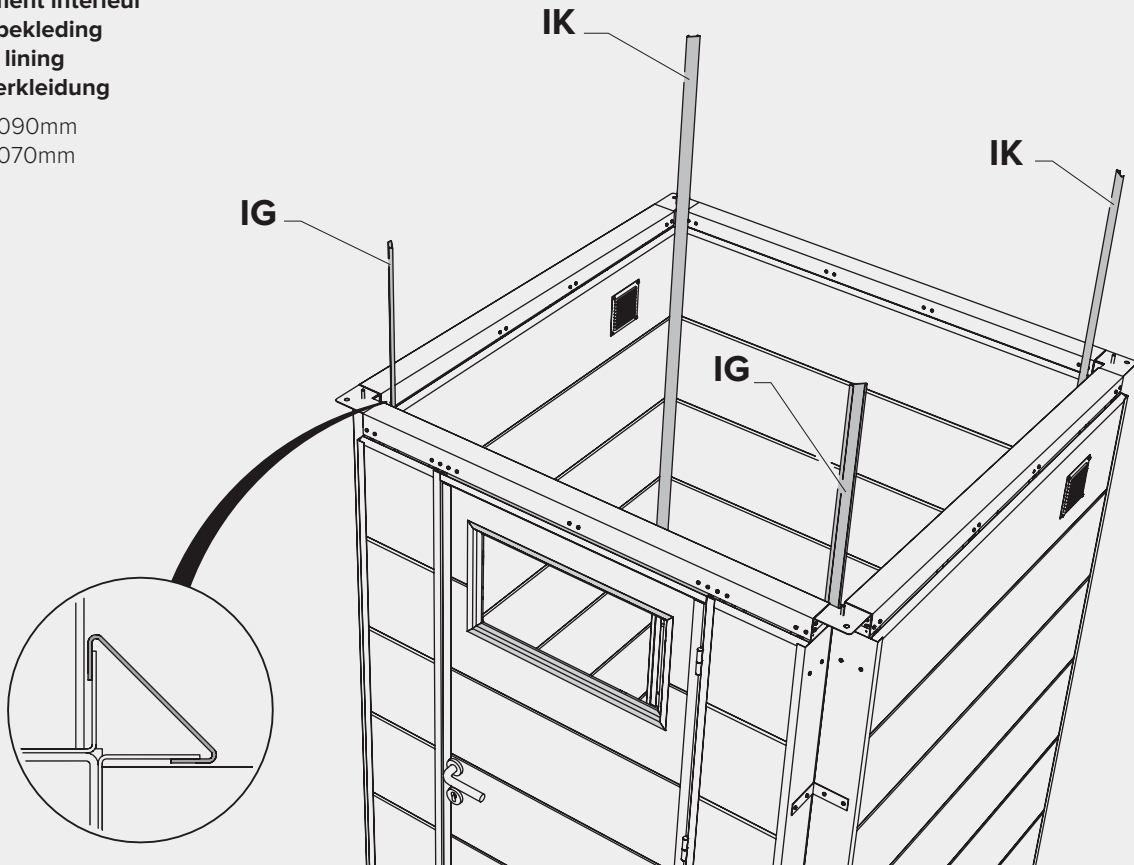

A + B + C + D Paroi / Wand / Wall / Wand

Option / Optie / Option / Option

revêtement intérieur
 binnenbekleding
 interior lining
 Innenverkleidung

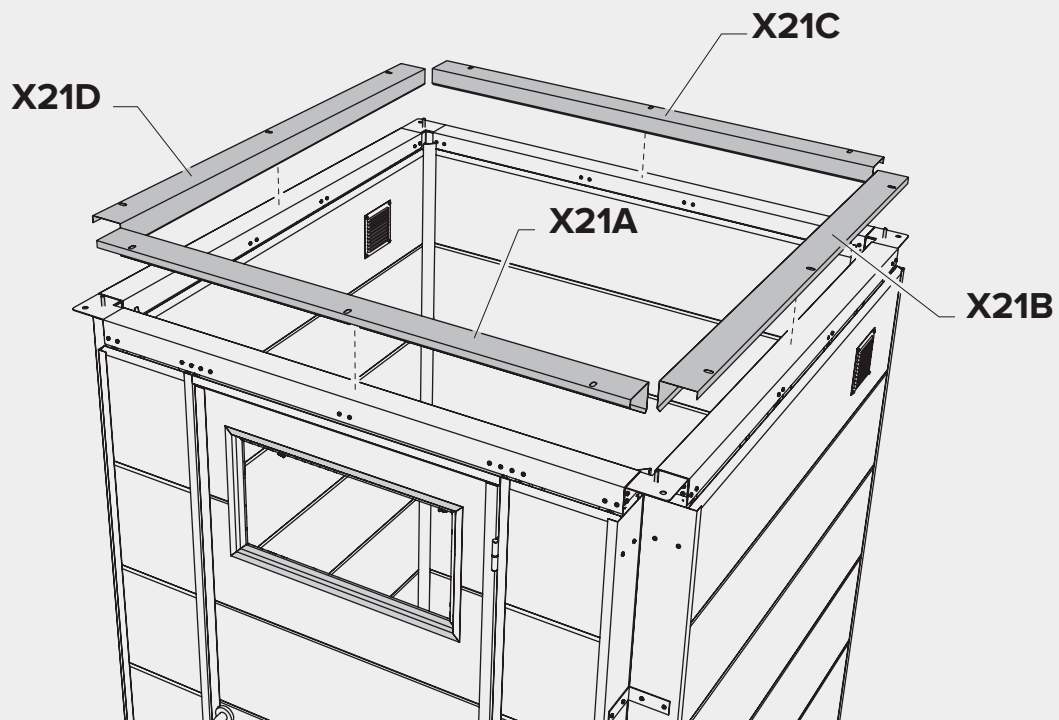

A + B + C + D Paroi / Wand / Wall / Wand

Option / Optie / Option / Option

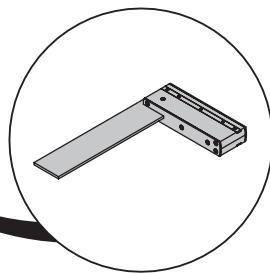
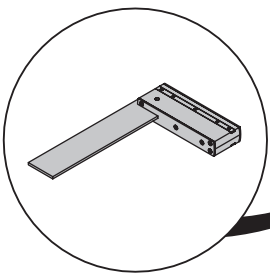
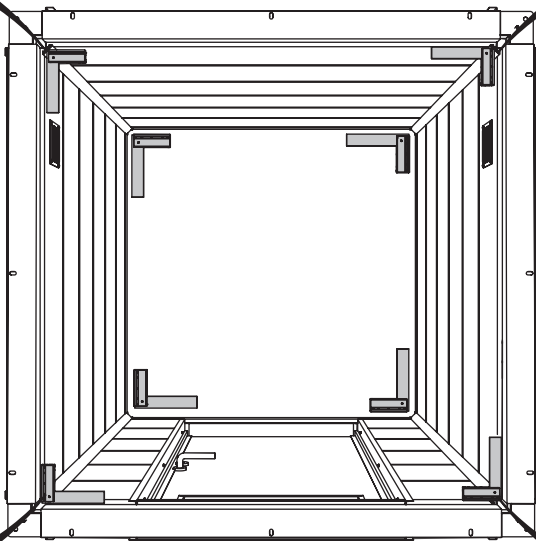
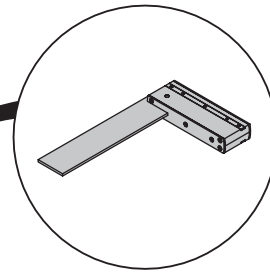
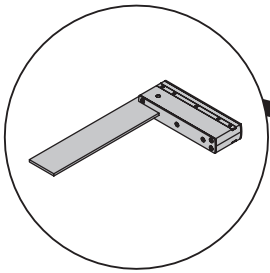
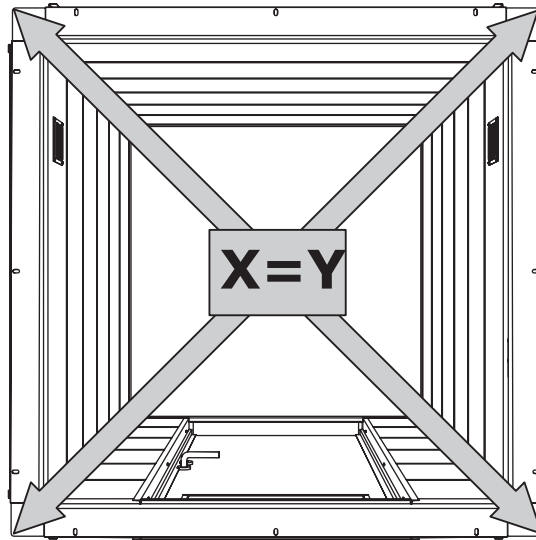
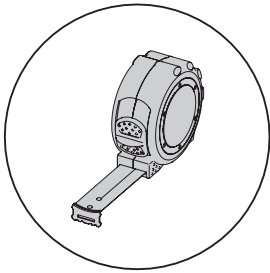

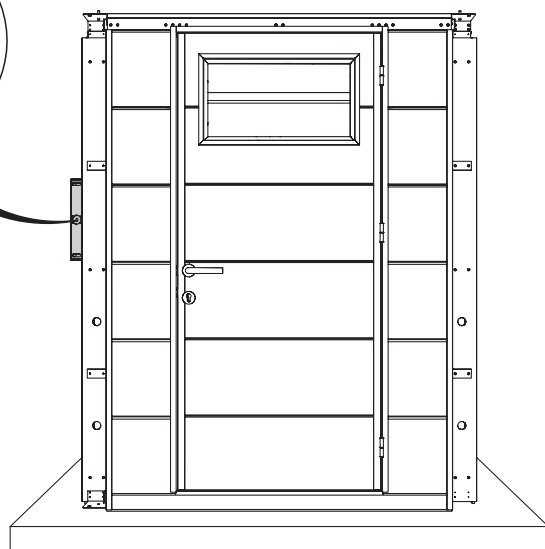
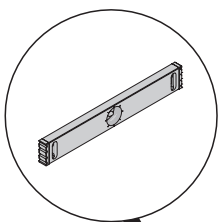
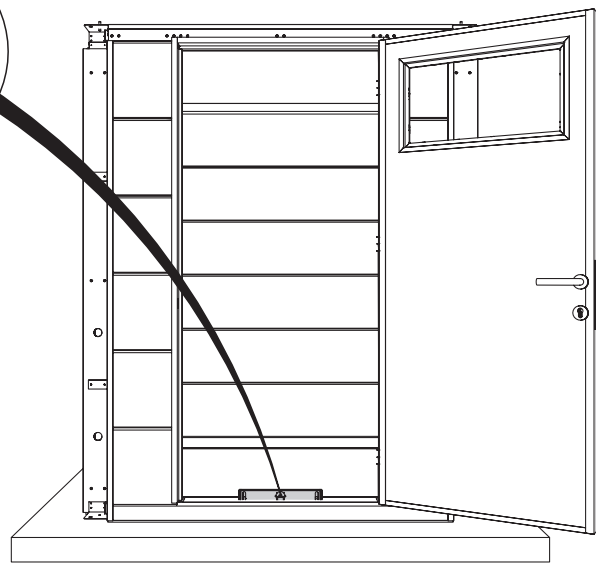
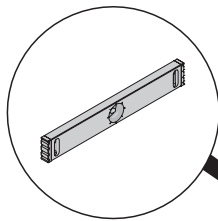
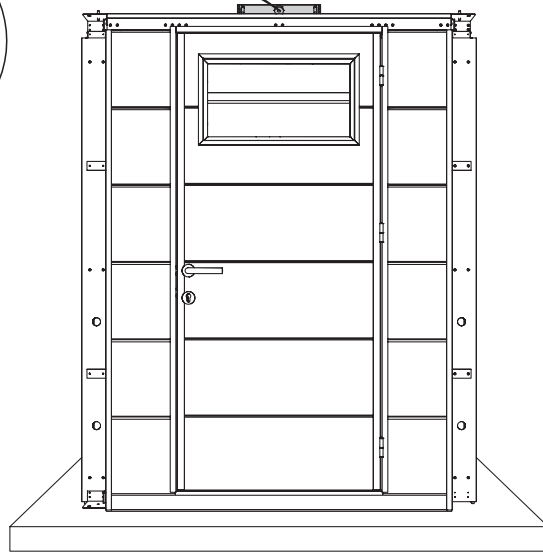
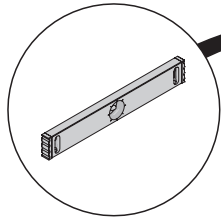

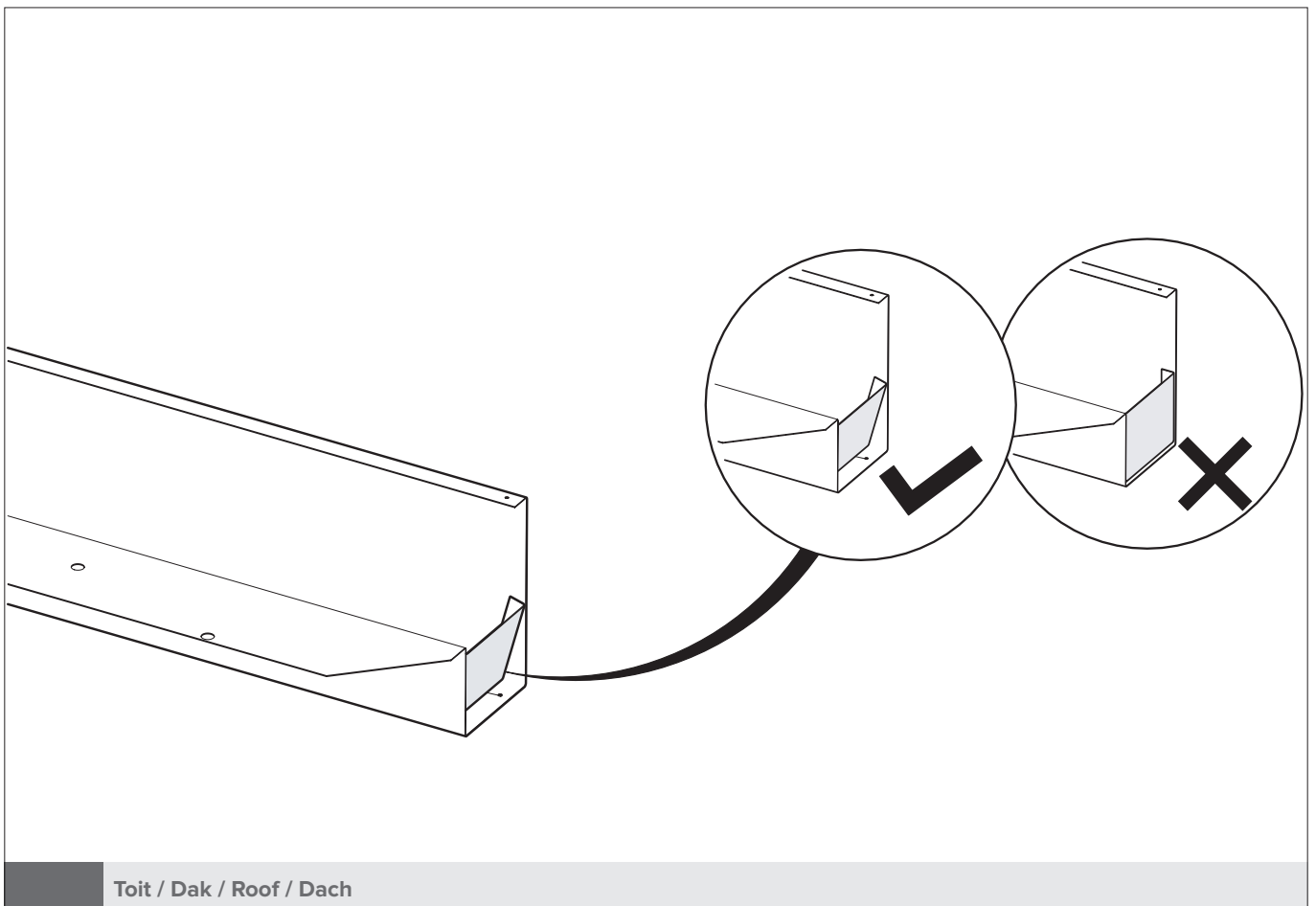
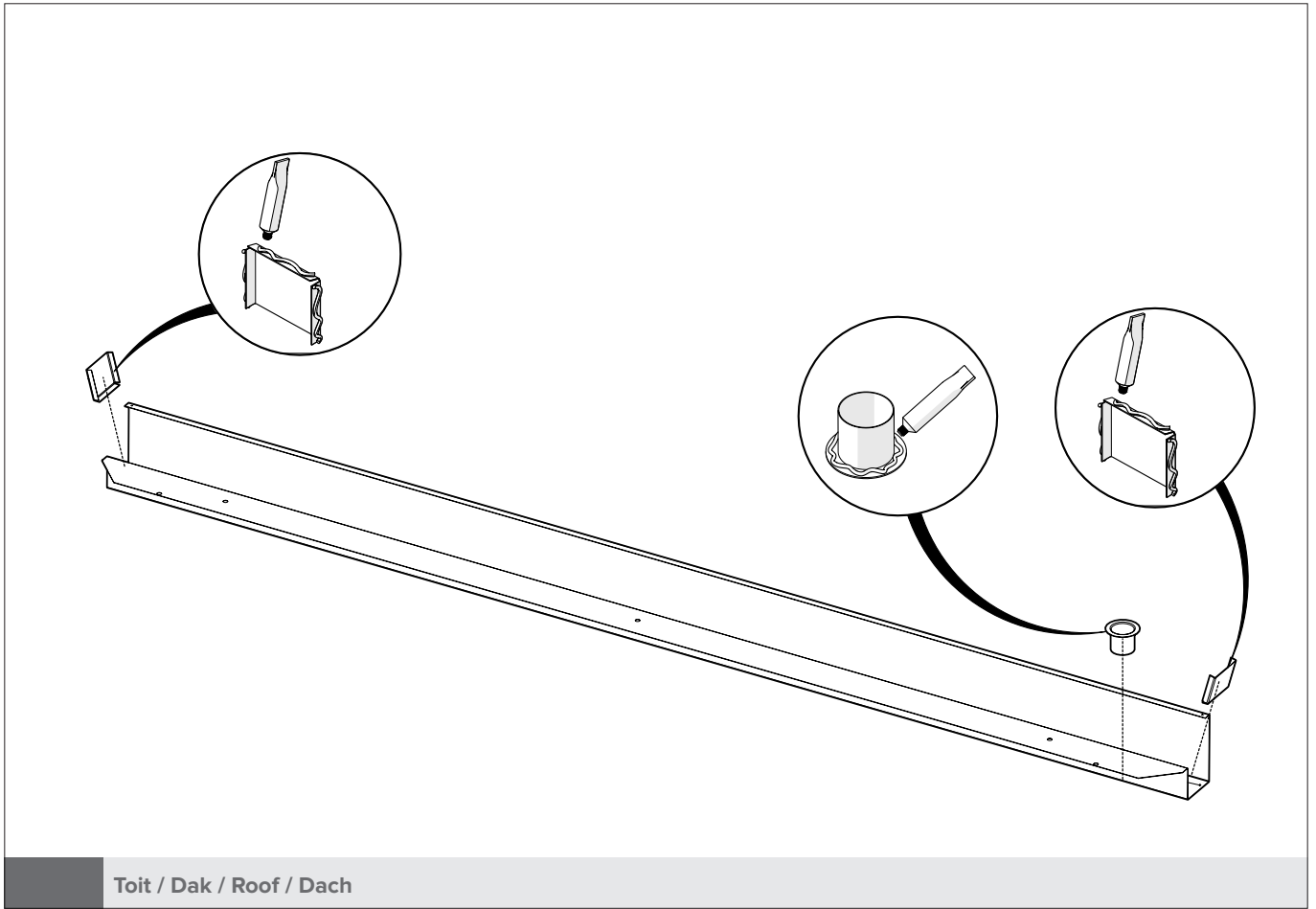

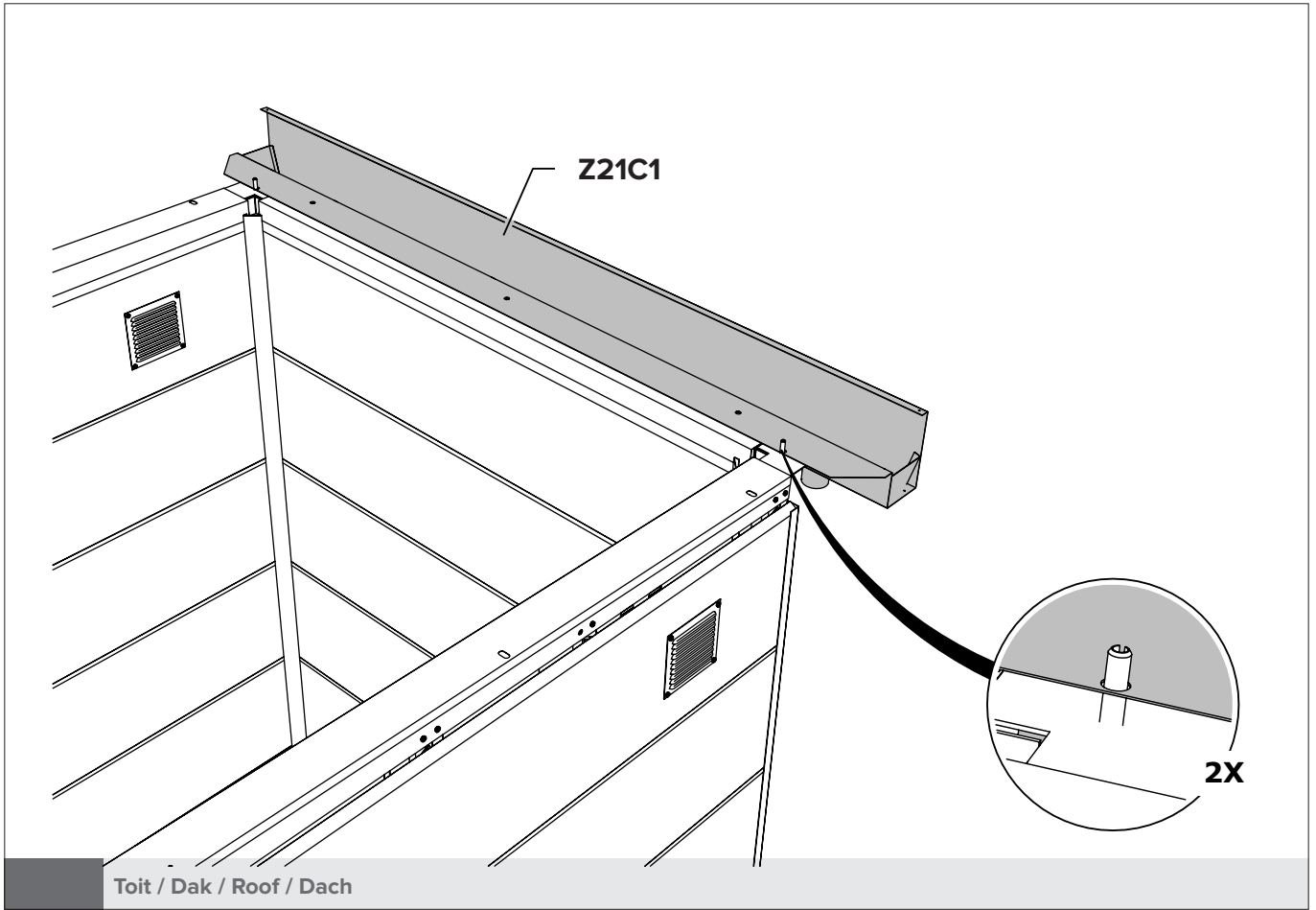

Retirer le film / Verwijder folie / Remove foil / Folie entfernen

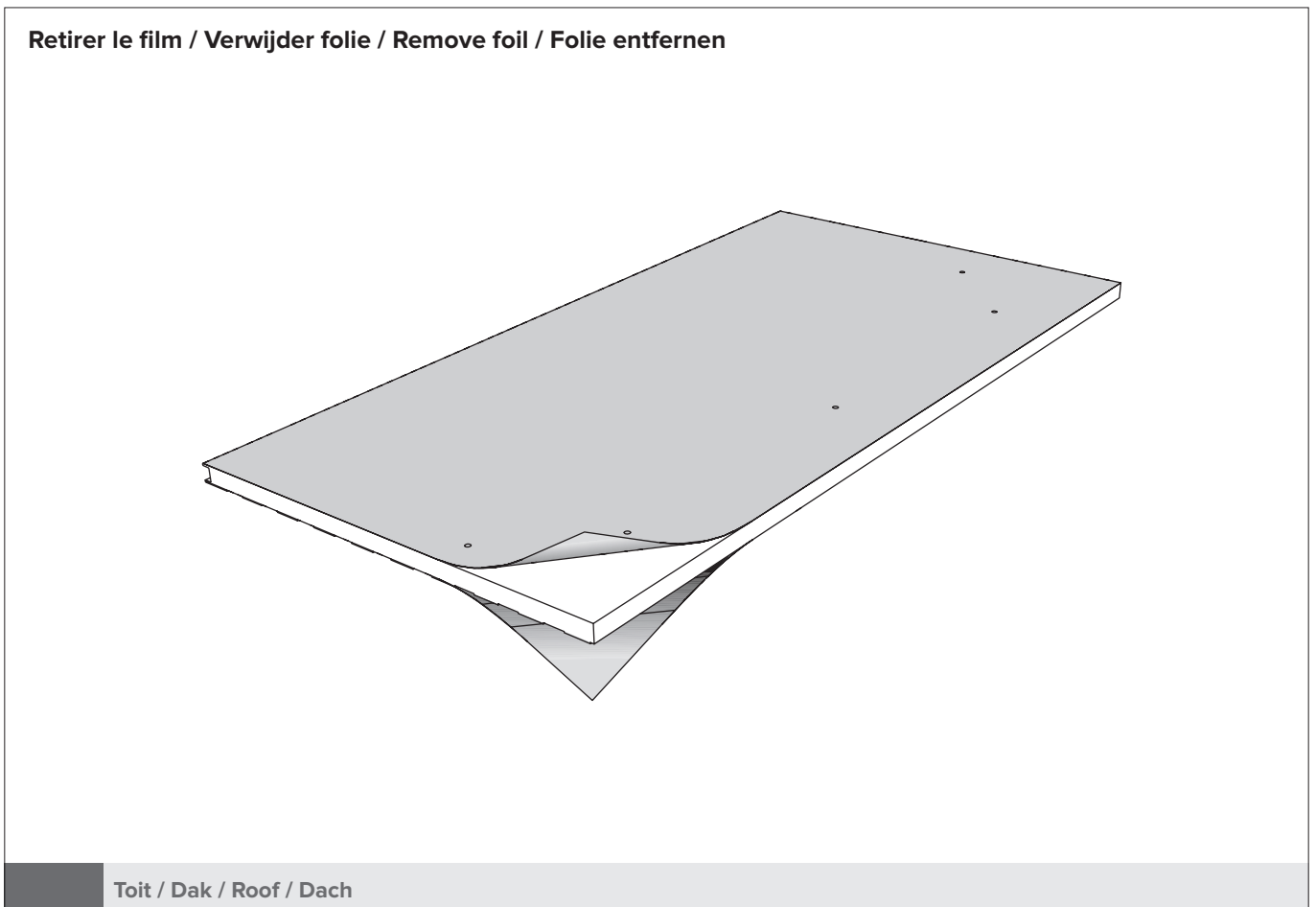

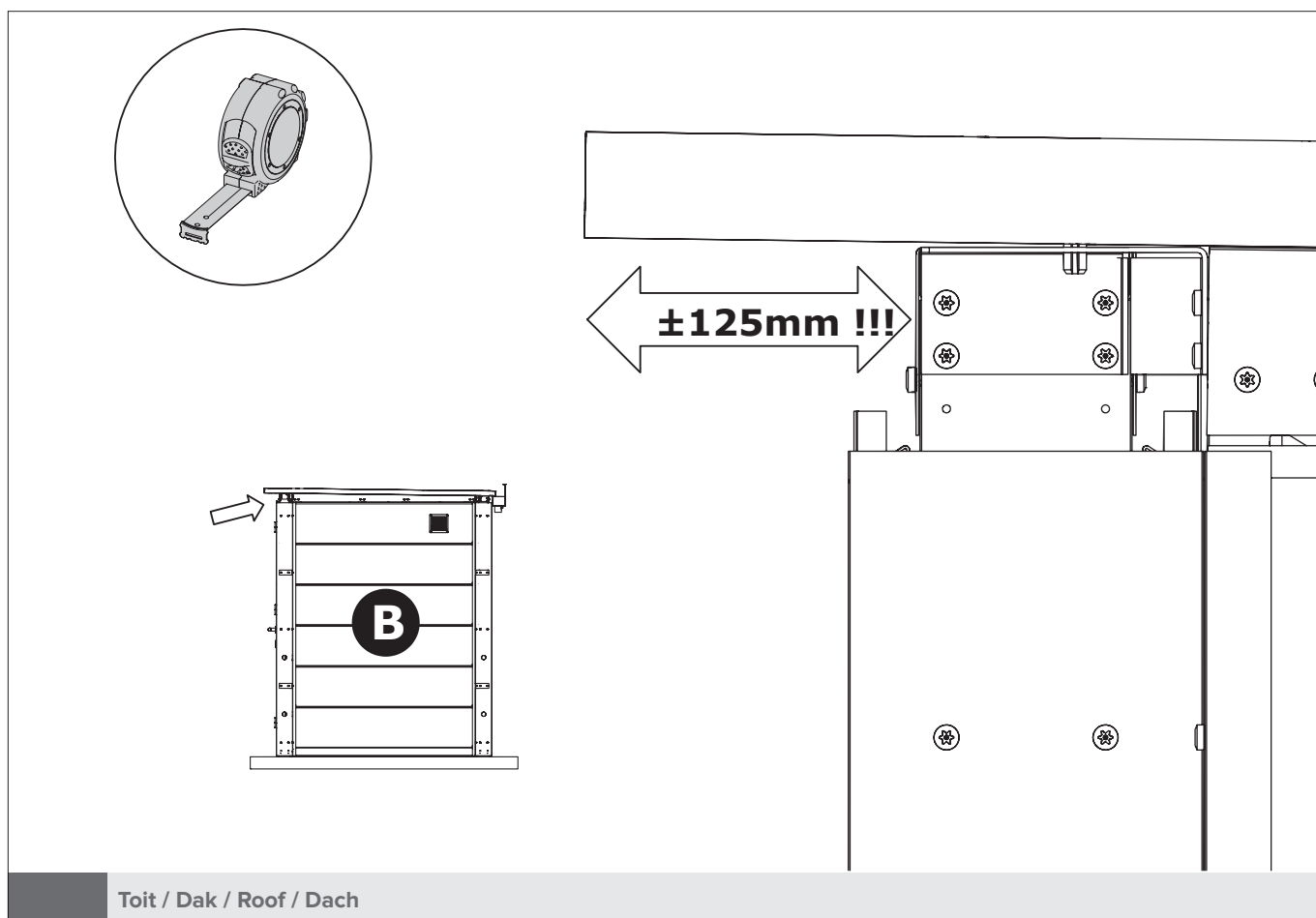
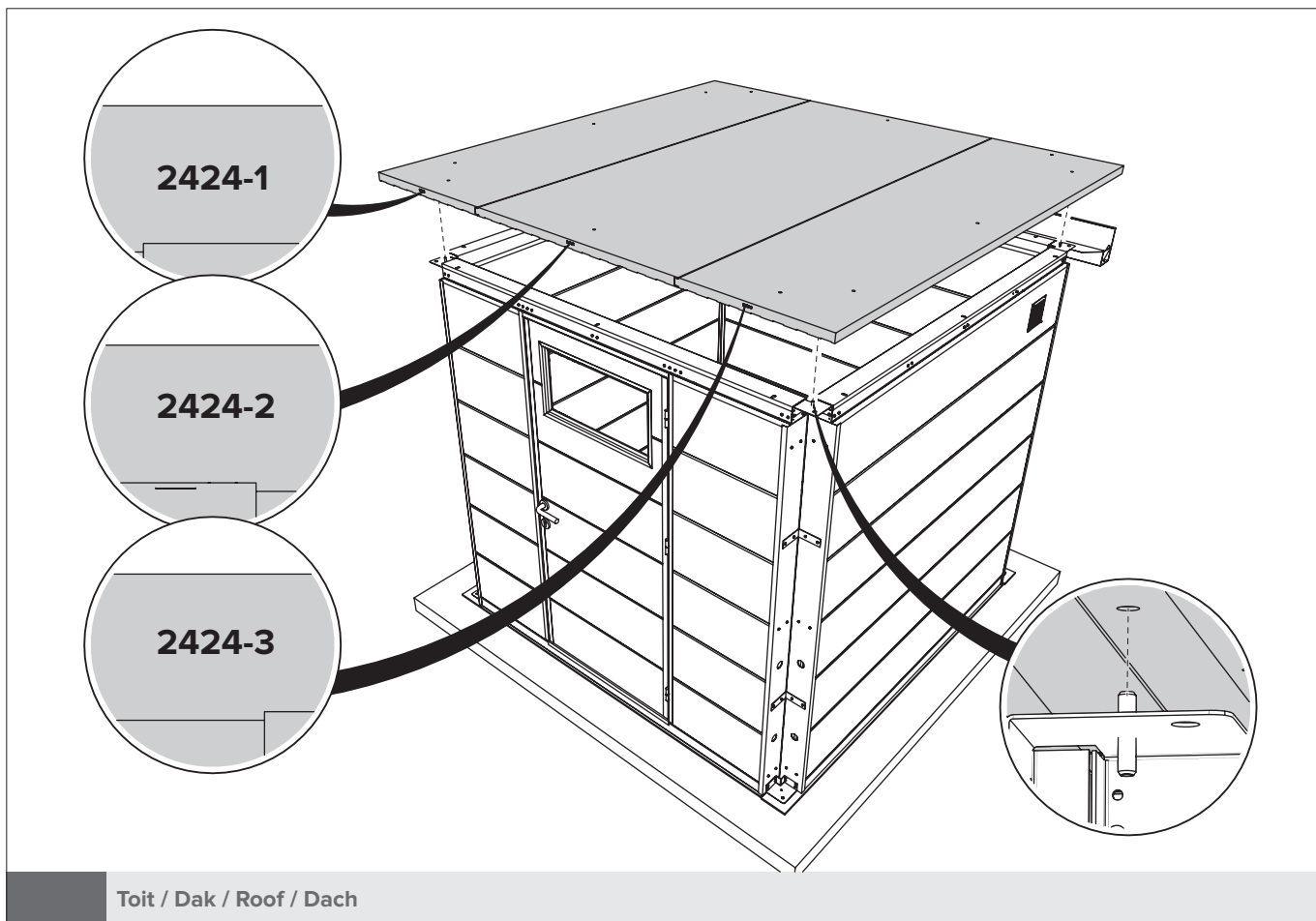

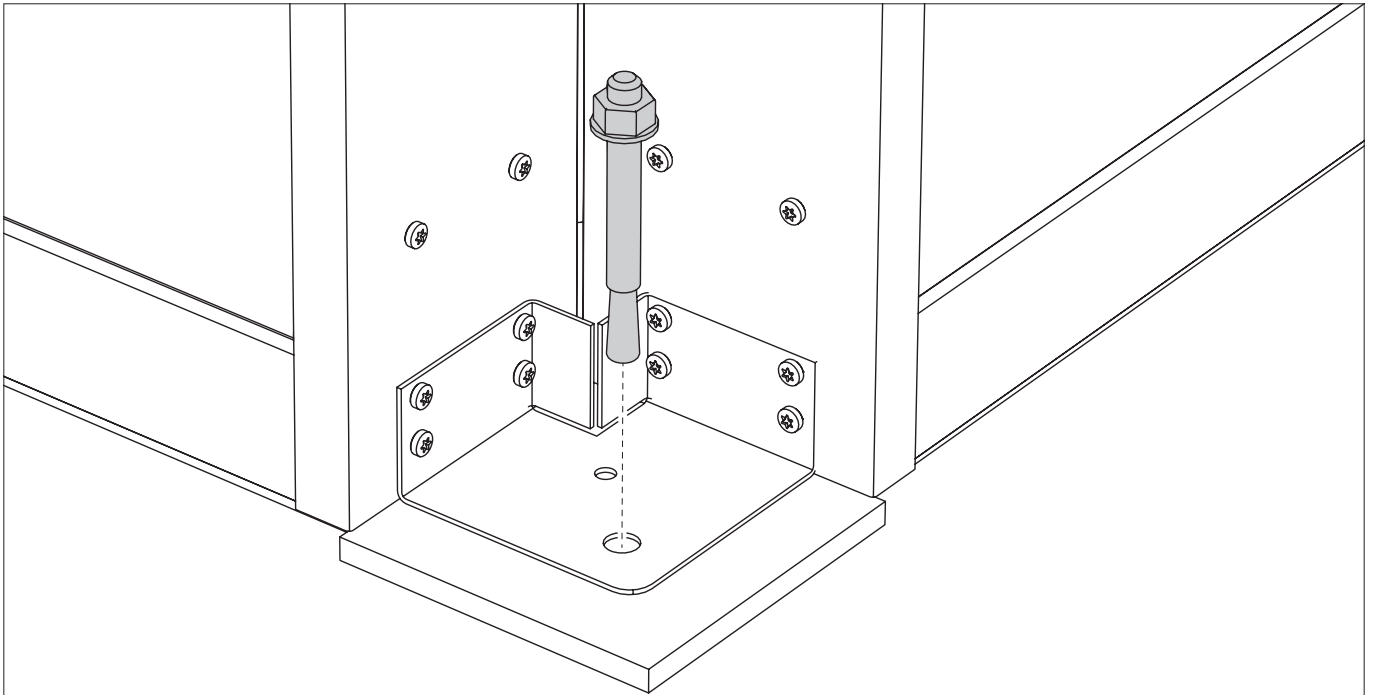

Exemple donné pour un sous-sol en béton. Fixer l'abri de jardin dans les règles de l'art.
 Voorbeeld is voor beton-ondergrond. Tuinhuisje fixeren volgens de regels van de kunst.
 Example is for concrete substrate. Fix the garden shed in accordance with good practise.
 Beispiel ist für Betonuntergrund. Fachgerechte Befestigung des Gartenhäuschens.

Ancrage / Verankering / Anchoring / Verankerung

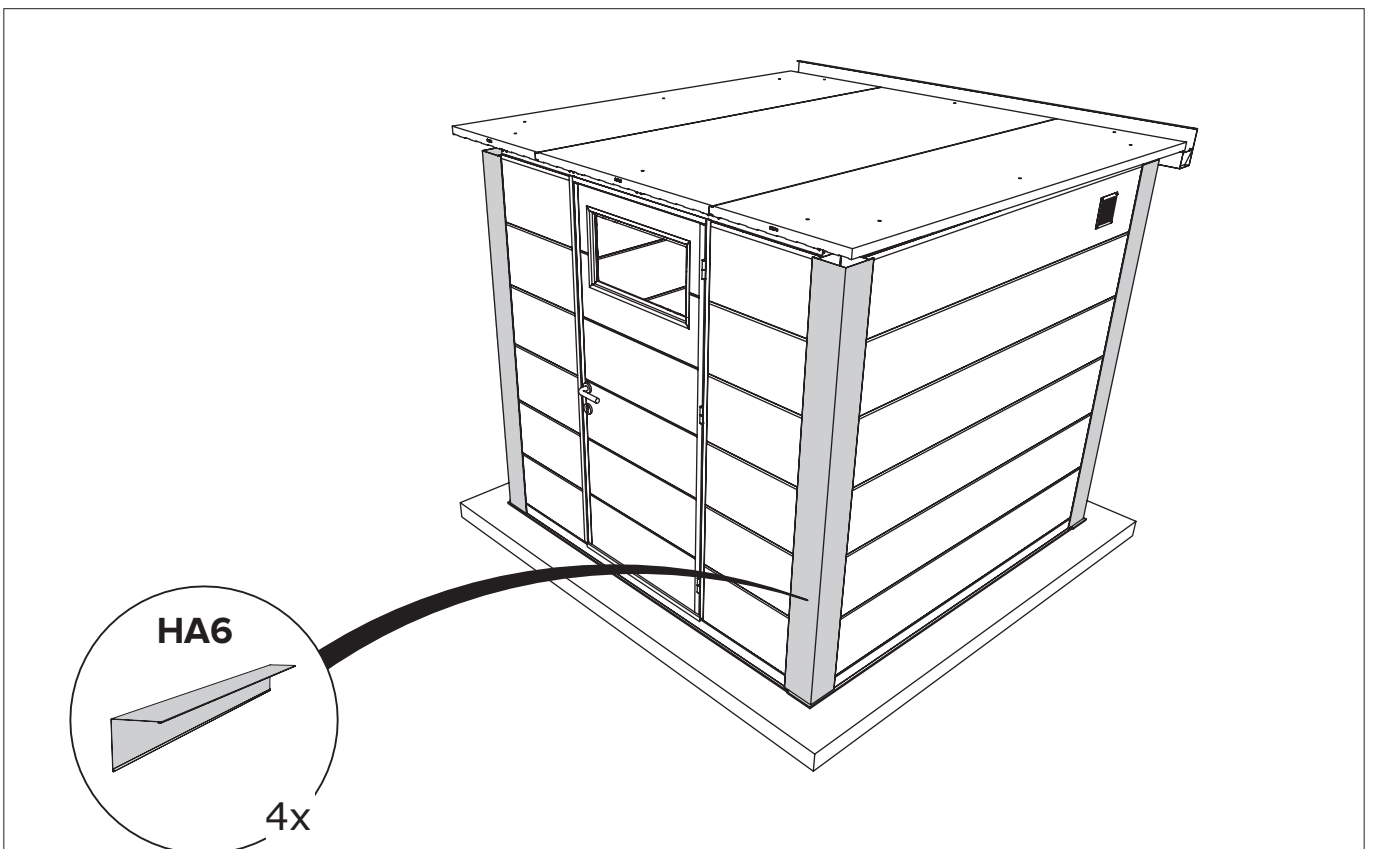

Angle / Hoek / Corner / Ecke

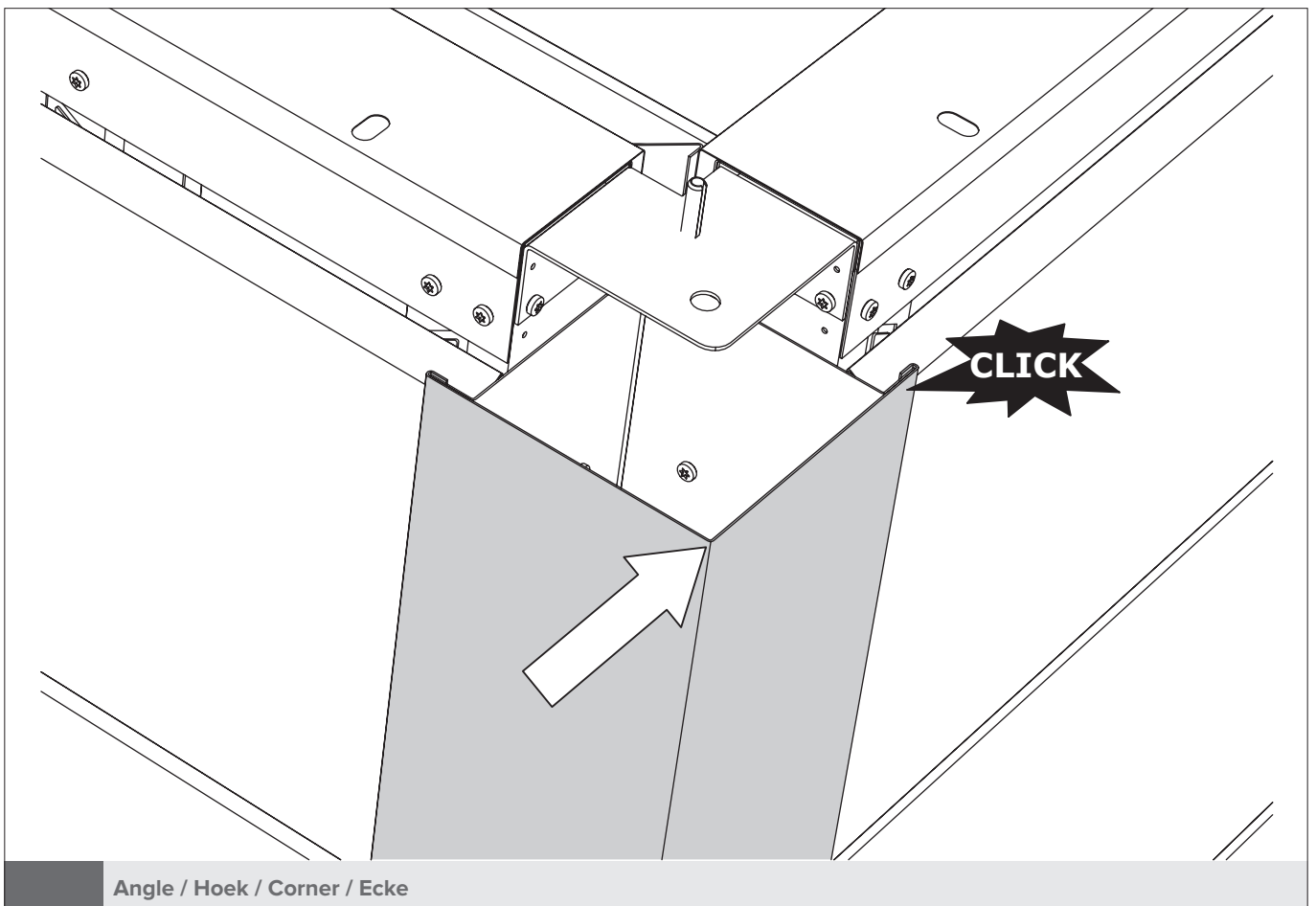
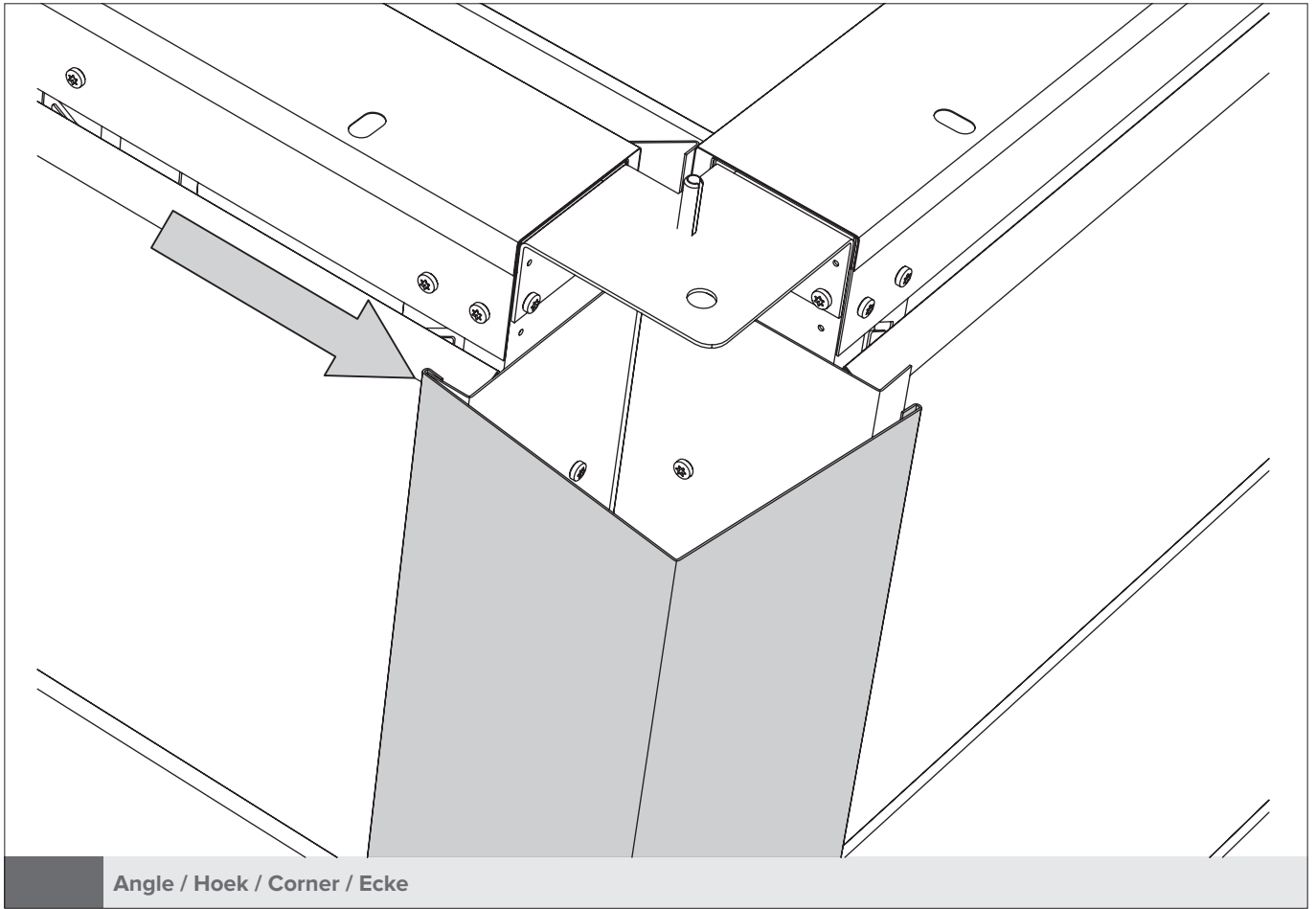

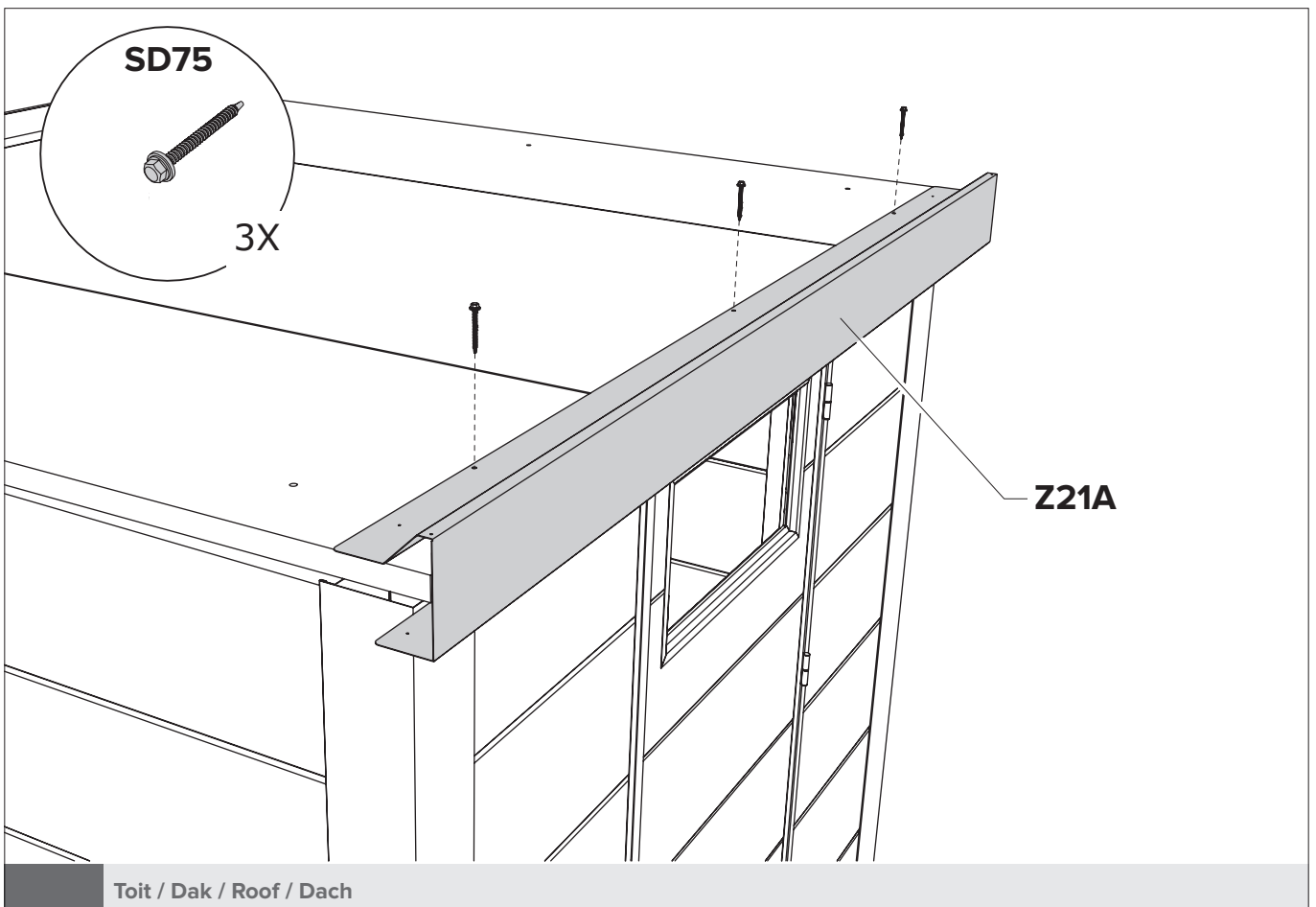
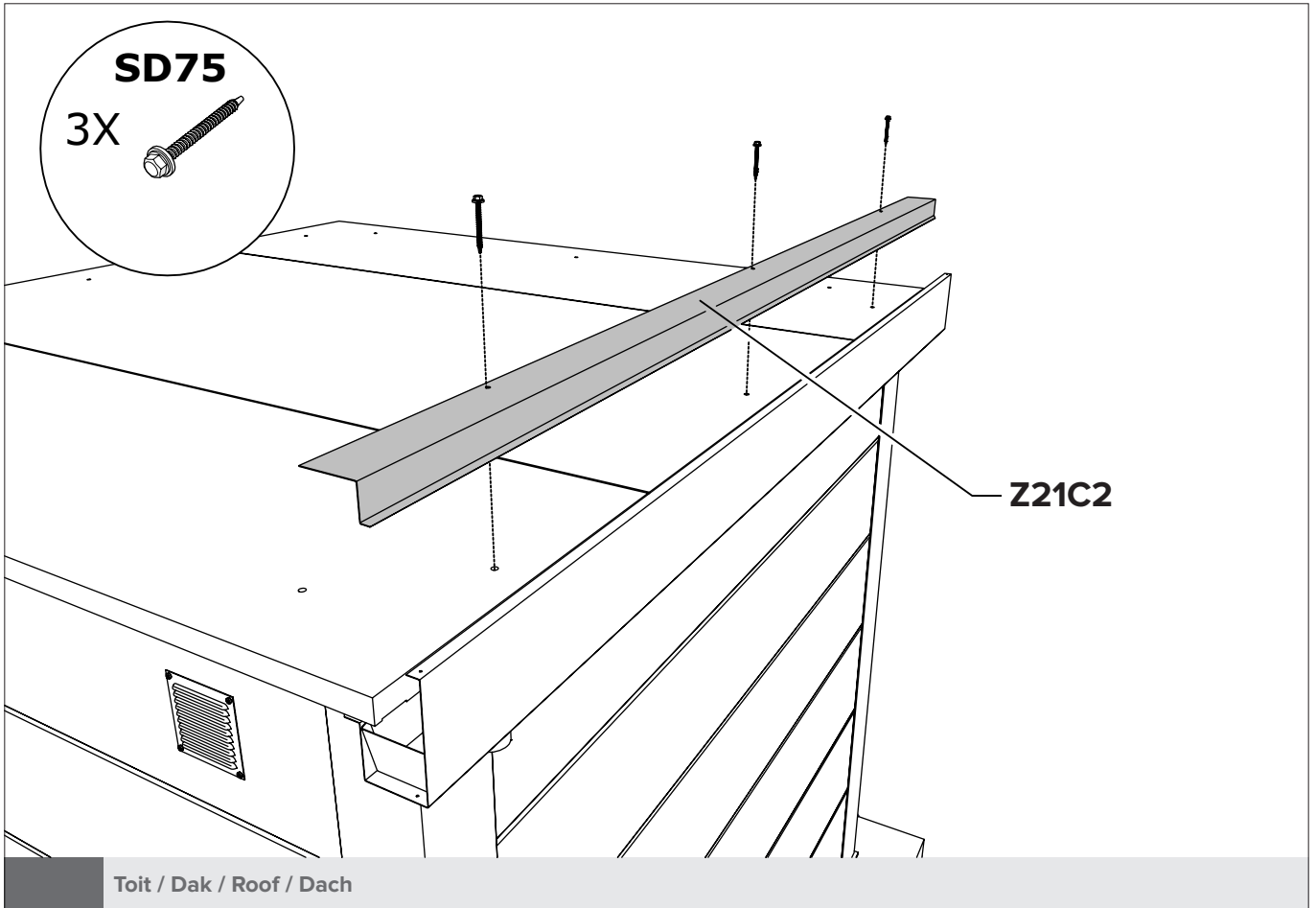

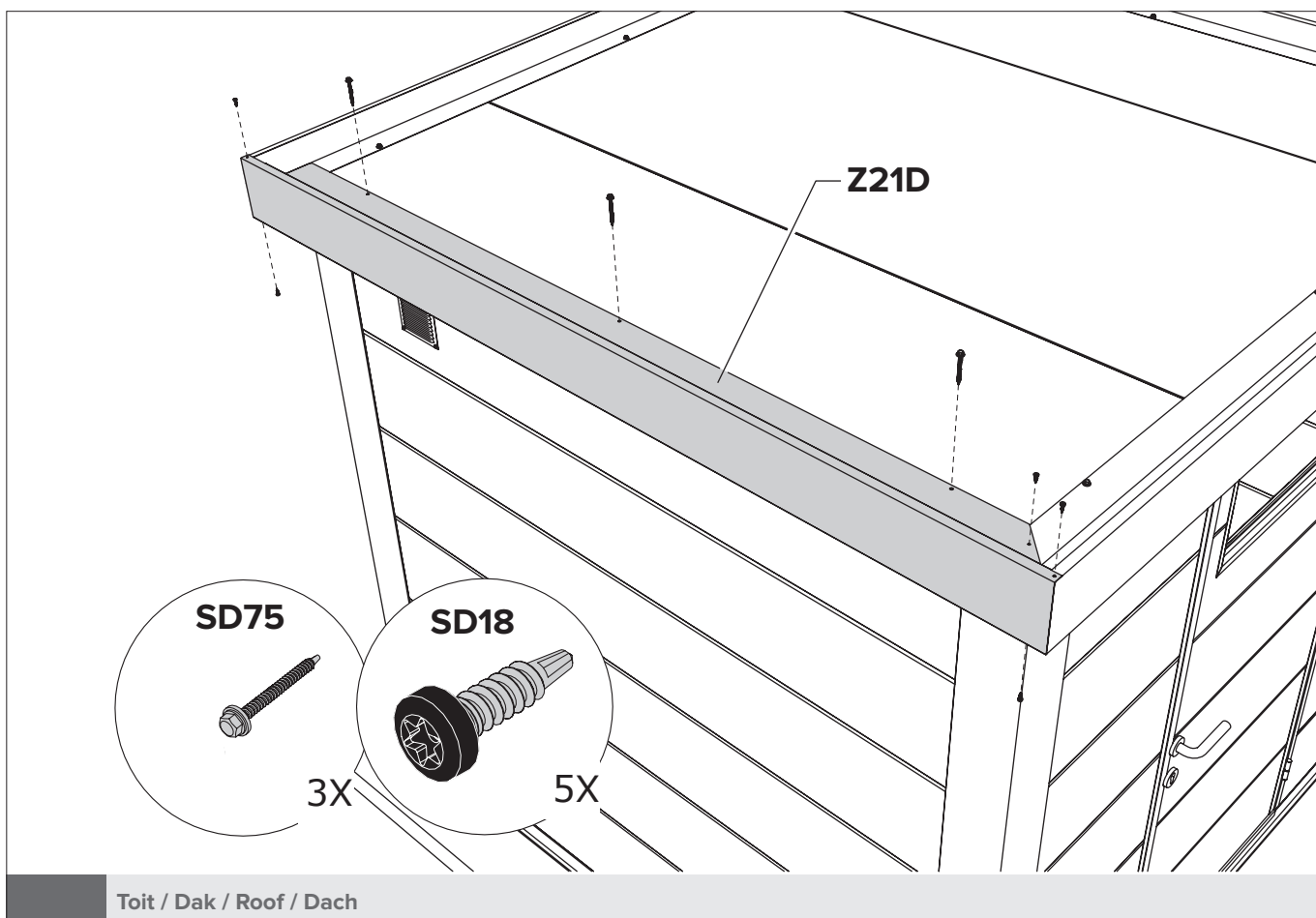
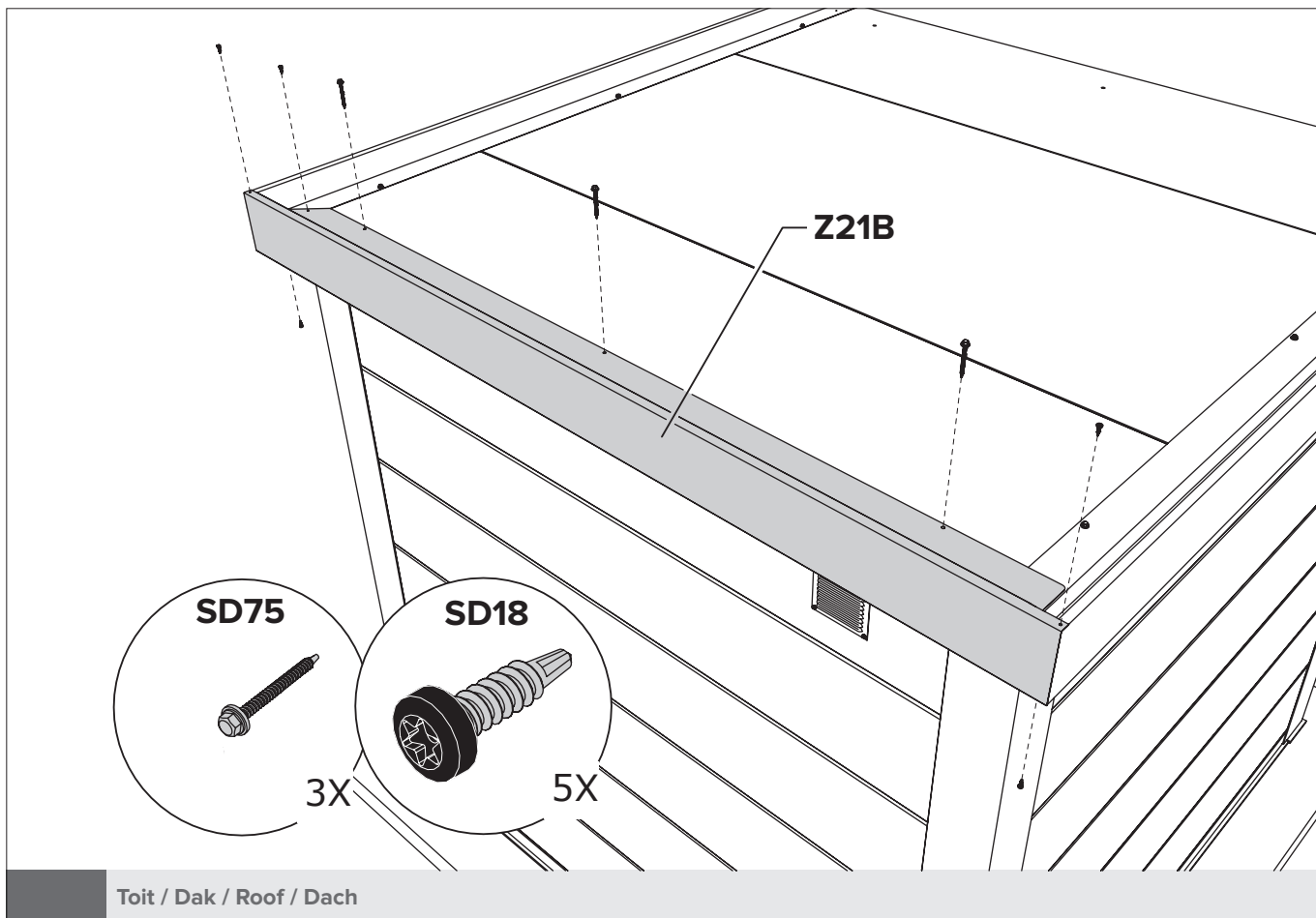

Préparation du ruban auto-adhésif:

1. Bien nettoyer la surface afin qu'il n'y ai ni poussière, ni humidité.
2. Chauffer la surface dans le cas d'une température extérieure $<15^{\circ}\text{C}$.

Vorbereitung zelfklevende tape:

1. Oppervlak stof- en vochtvrij maken".
2. Bij $<15^{\circ}\text{C}$ is opwarmen ondergrond d.m.v. warmtepistool (Föhn) vereist".

Preparation of self-adhesive tape:

1. Make the surface dust-free and moisture-free.
2. Heat up the surface in case of $<15^{\circ}\text{C}$ outside temperature.

Vorbereitung des Klebebandes:

1. Machen Sie die Oberfläche staubfrei und feuchtigkeitsfrei.
2. Erwärmen Sie Oberfläche bei einer Außentemperatur von $<15^{\circ}\text{C}$.

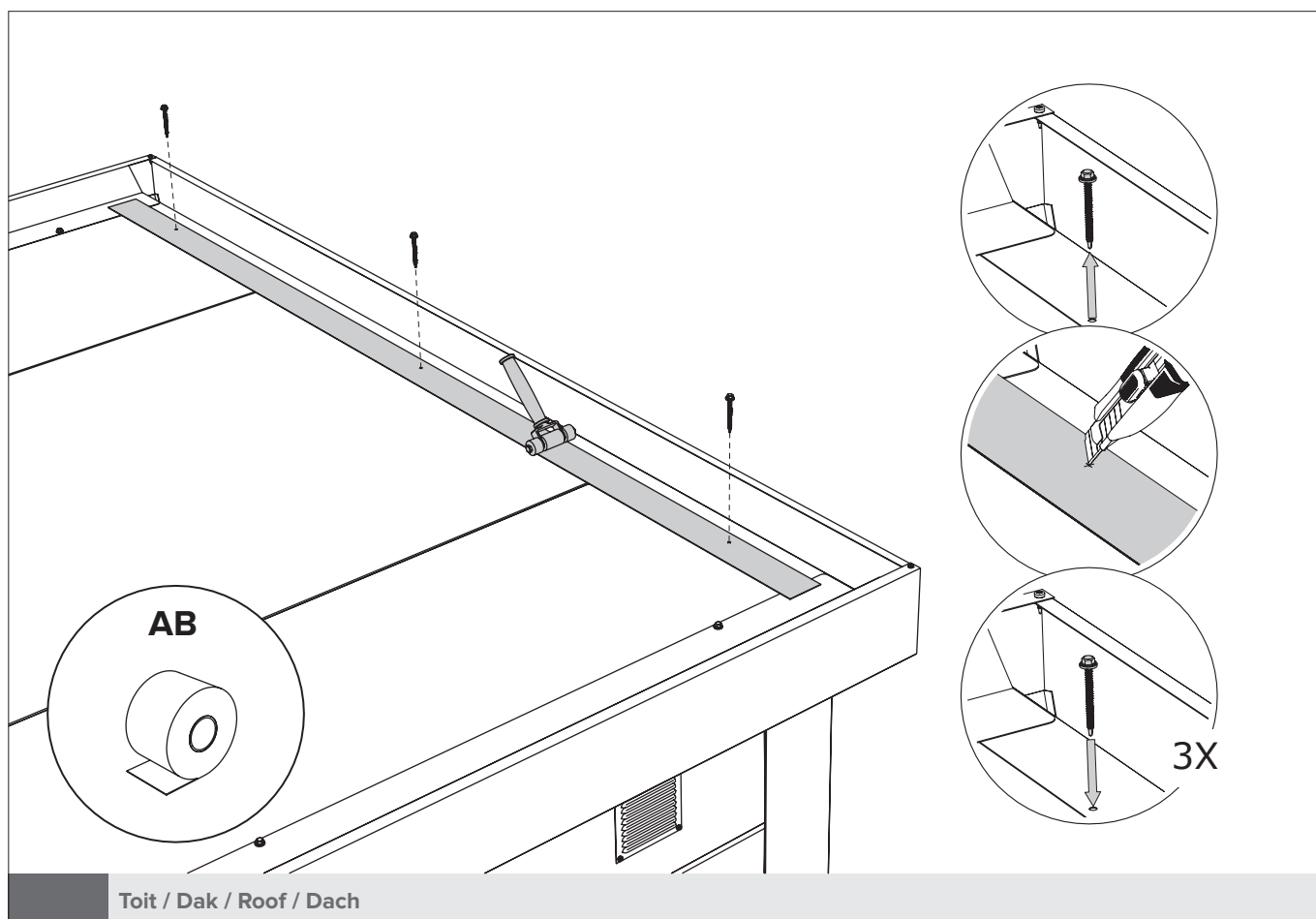

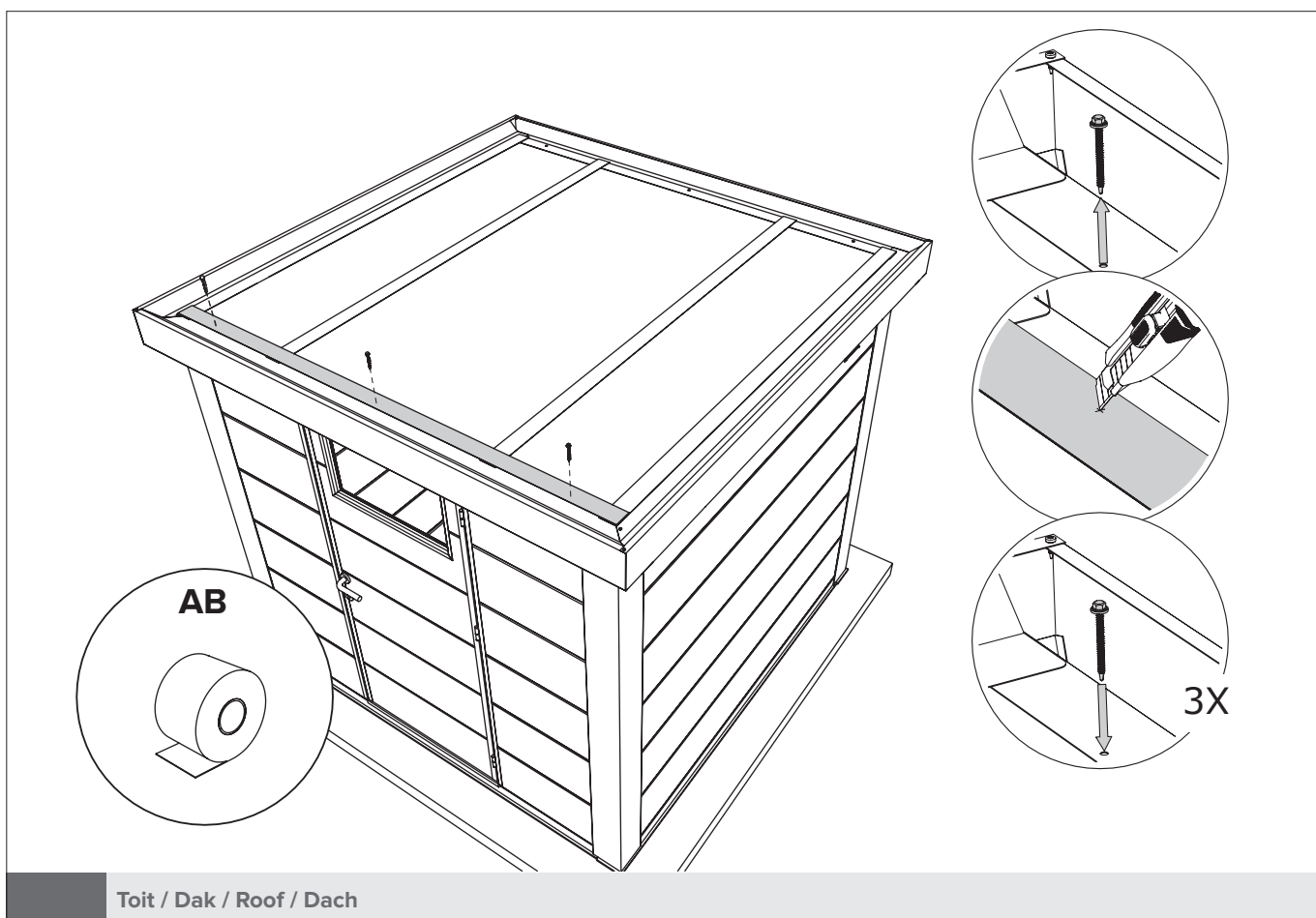
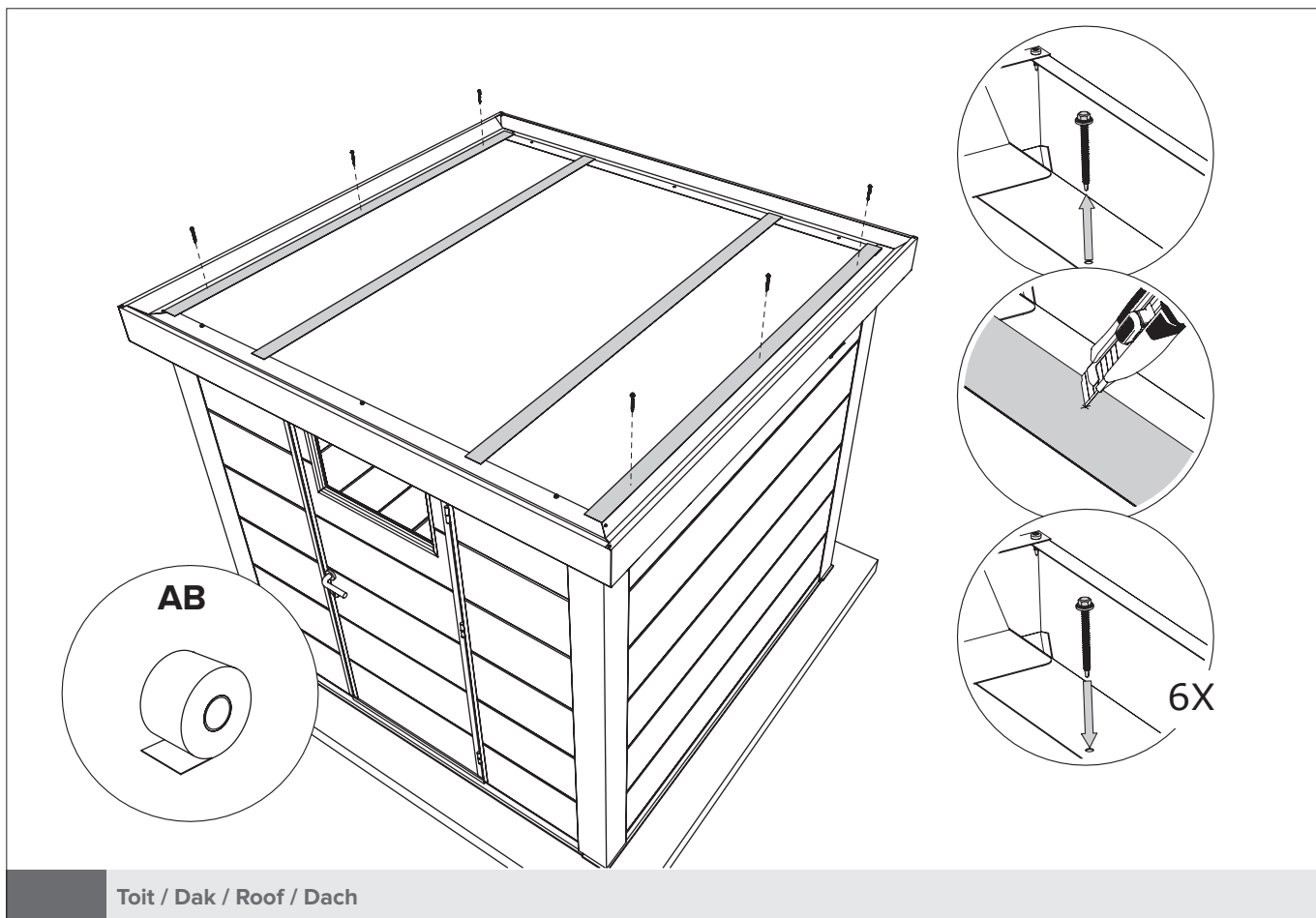

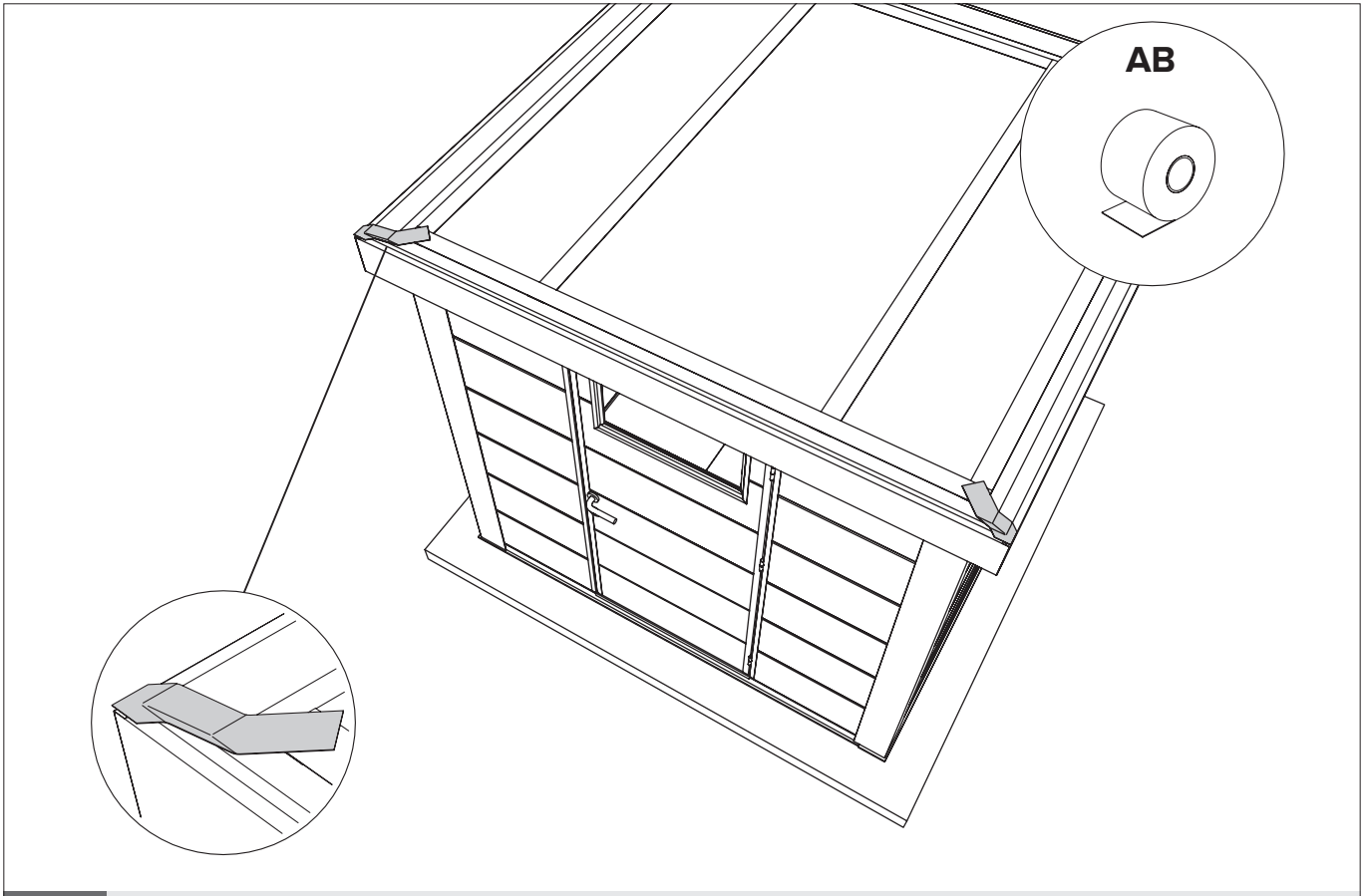

Toit / Dak / Roof / Dach

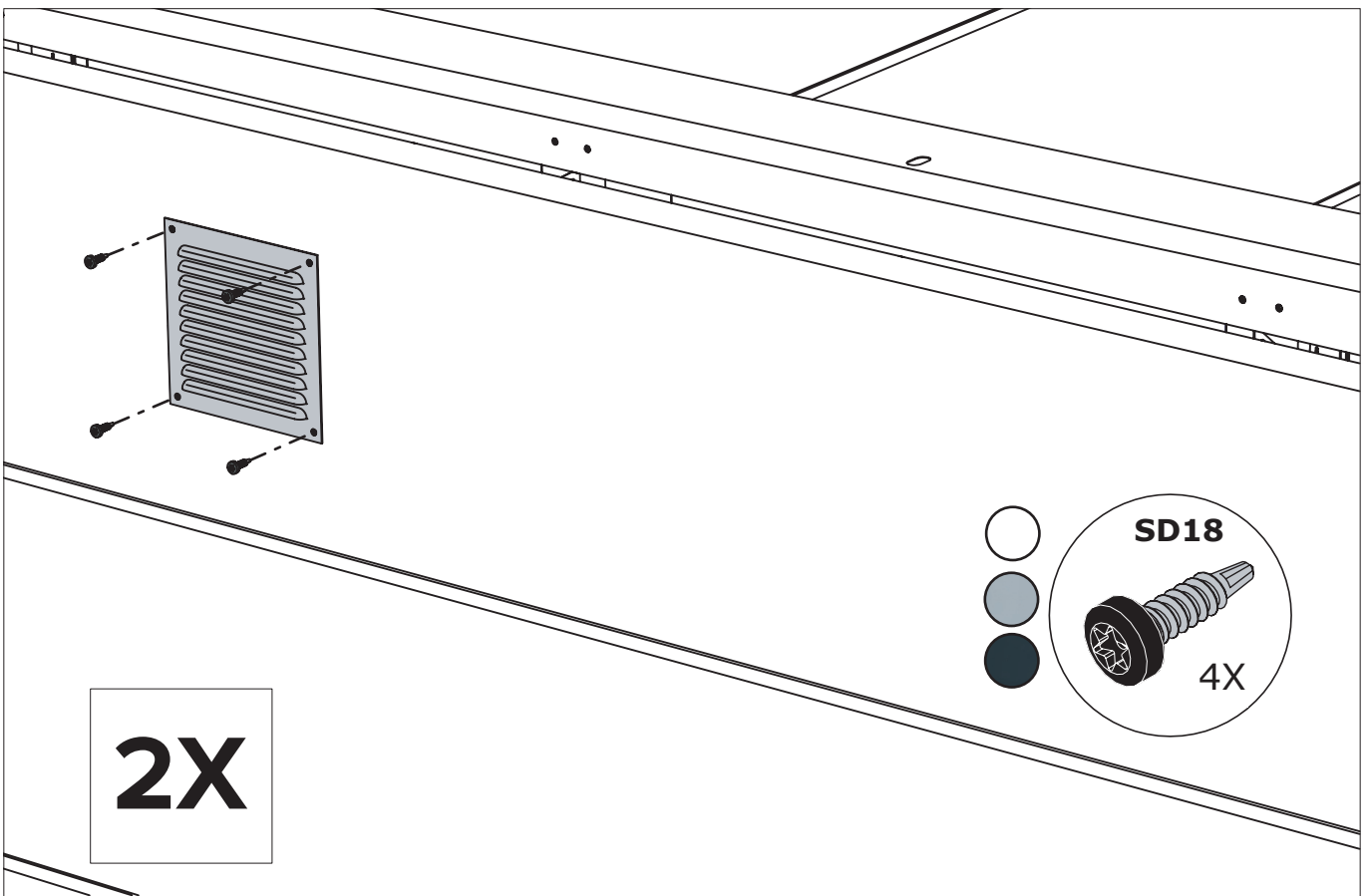

2X

Drain / Afwatering / Drainage / Drainage

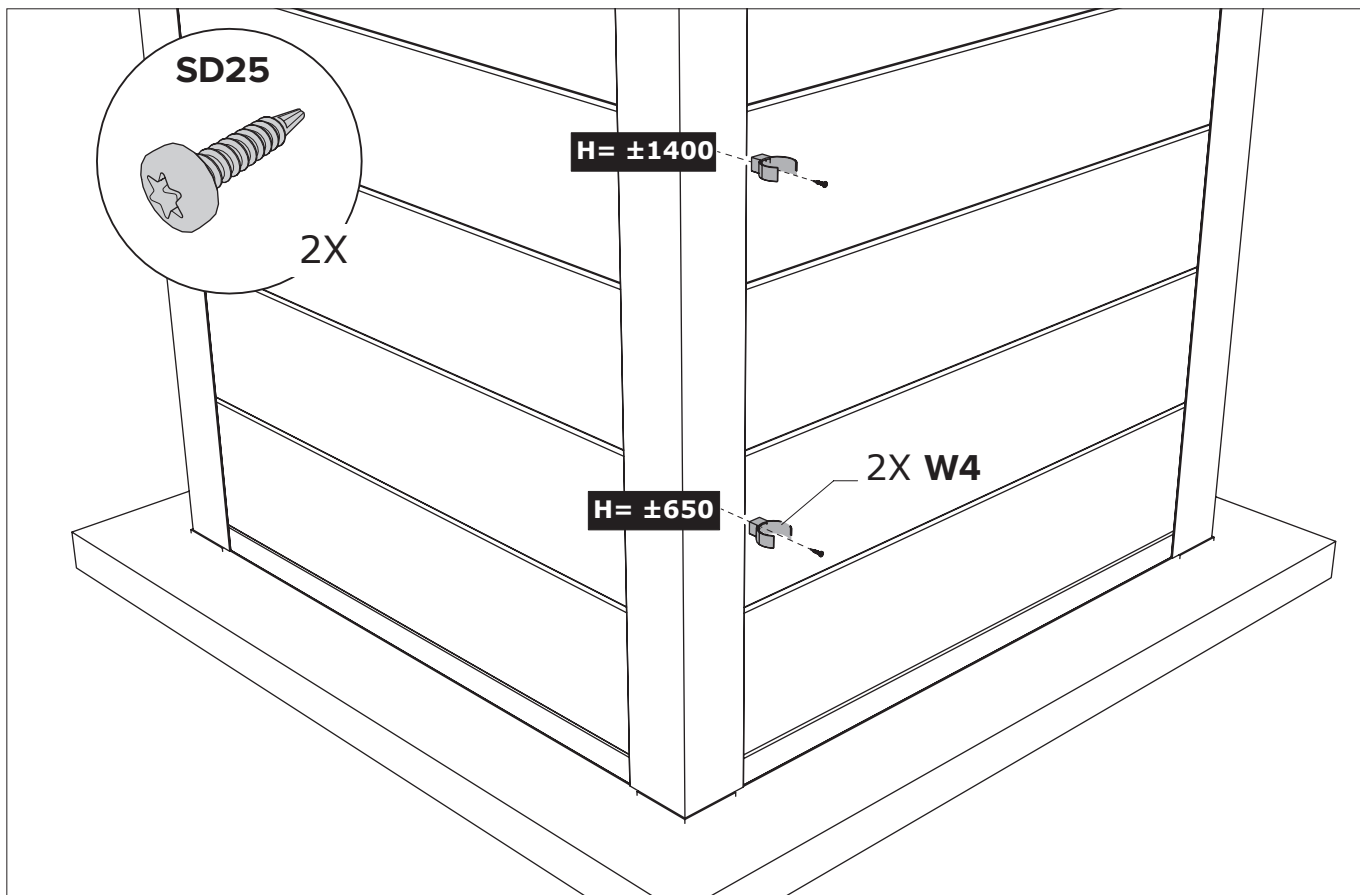

Drain / Afwatering / Drainage / Drainage



Drain / Afwatering / Drainage / Drainage

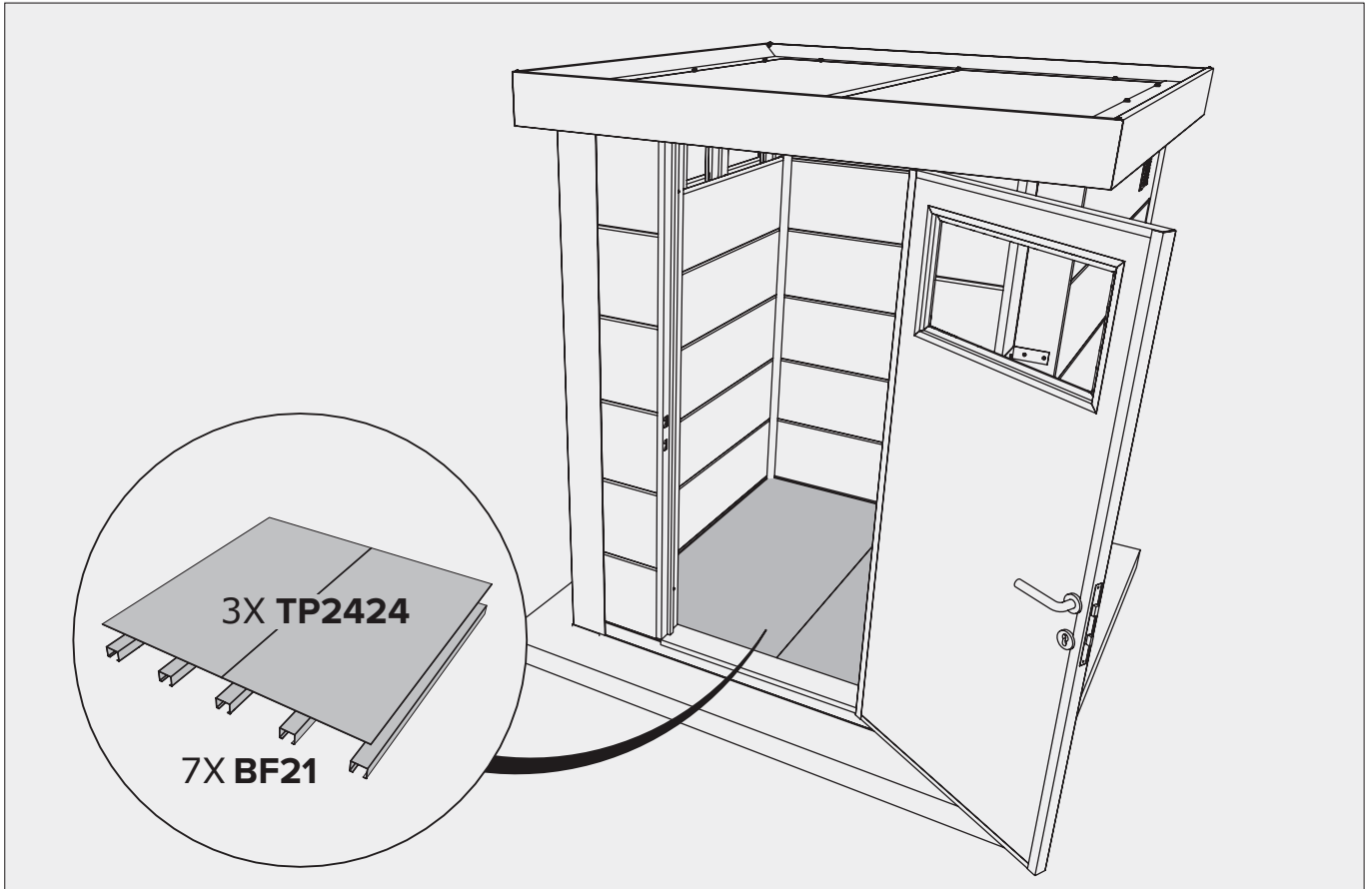

Sol / Vloer / Floor / Boden

Option / Optie / Option / Option

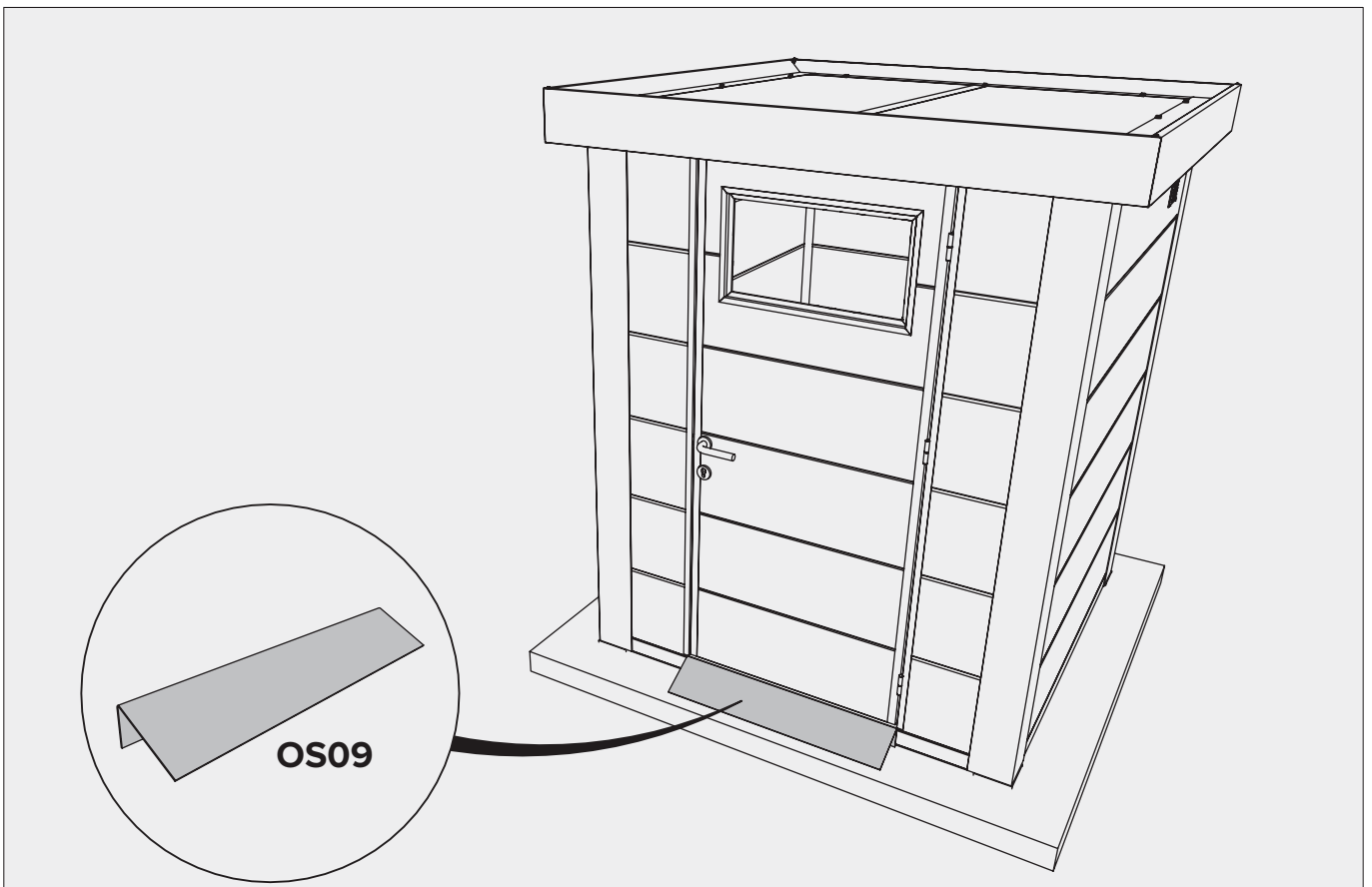

Rampe / Oprijplaat / Ramp / Rampe

Option / Optie / Option / Option

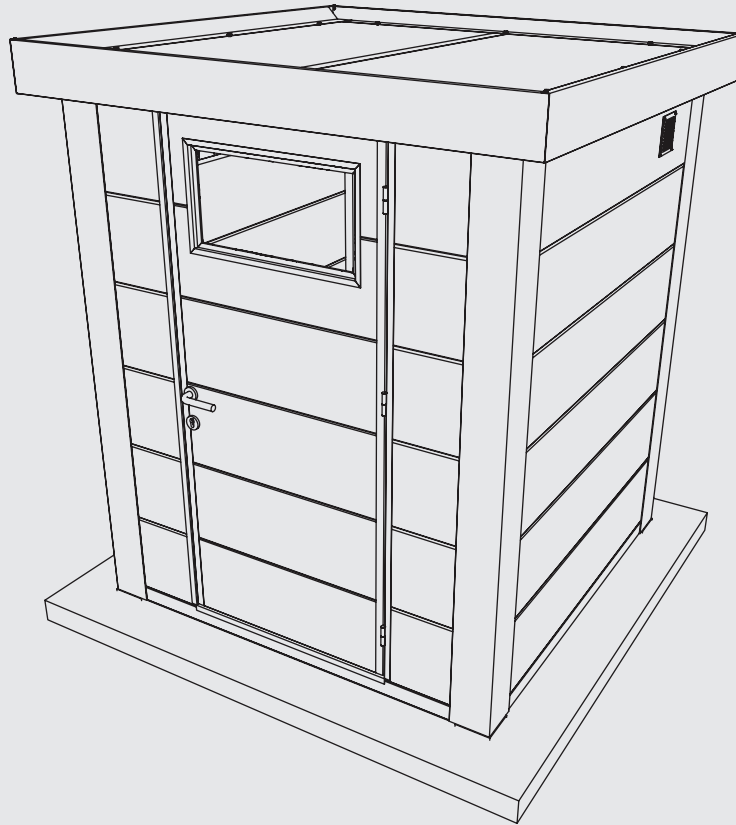

Merci de respecter l'environnement !

Pour une élimination correcte des déchets, il faut trier les différents matériaux conformément à la législation en vigueur.
Droits d'auteur Telluria. Tous droits réservés. Aucun élément de la présente publication ne peut être reproduit ou diffusé sans l'autorisation écrite de Telluria. Les informations figurant dans la présente publication sont, pour des raisons techniques et/ou commerciales, sujettes à modification sans avis préalable.

Draag zorg voor het milieu!

Voor een correcte afvalverwijdering moeten de verschillende materialen volgens de toepasselijke regelgeving worden gescheiden.
Auteursrechten Telluria. Alle rechten voorbehouden. Niets in deze publicatie mag worden gereproduceerd of verdeeld zonder de schriftelijke toestemming van Telluria.
De gegevens in deze publicatie zijn, omwille van technische en/of commerciële redenen, onderhevig aan wijziging zonder voorafgaande kennisgeving.

Protect the environment!

To ensure waste is disposed of correctly, the different materials must be separated according to the applicable regulations.
Copyright Telluria. All rights reserved. Nothing in this publication may be reproduced or distributed without written permission from Telluria. The information in this publication is subject to change for technical and/or commercial reasons at any time and without notice.

Achten Sie auf die Umwelt!

Um eine ordnungsgemäße Entsorgung zu gewährleisten, müssen die verschiedenen Materialien entsprechend den geltenden Vorschriften getrennt werden.
Copyright Telluria. Alle Rechte vorbehalten. Kein Teil dieser Publikation darf ohne schriftliche Genehmigung von Telluria vervielfältigt oder verbreitet werden.
Aus technischen und/oder kommerziellen Gründen können sich die in dieser Publikation enthaltenen Informationen ohne vorherige Ankündigung ändern.

VOUS AVEZ DES QUESTIONS SUR CE PRODUIT:

Mail du service clientèle: CLASSICO-service@telluria.eu

HEEFT U VRAGEN OVER DIT PRODUCT:

Mailadres klantendienst: CLASSICO-service@telluria.eu

DO YOU HAVE QUESTIONS ABOUT THIS PRODUCT:

Customer Service Mail: CLASSICO-service@telluria.eu

SIE HABEN FRAGEN ZU DIESEM PRODUKT:

Kundendienst-Mail: CLASSICO-service@telluria.eu



COMPLAINT FORM BESCHWERDEFORMULAR

Customer's first name/Vorname des Kunden

Customer's surname/Name des Kunden

Address/Anschrift

Town/city/Ort

Tel.

Mail

Order number/Bestellnummer*

** you can find this number on the parts list and the packing box/diese Nummer ist auf der Stückliste und auf dem Verpackungskarton zu finden.*

Date of receipt/Eingangsdatum

Date the complaint was discovered/
Datum, an dem der Beschwerdegrund
festgestellt wurde

Damaged part/Beschädigtes Teil*

** you can find the item number on the parts list/die Artikelnummer finden Sie in der Stückliste*

Missing part/Fehlendes Teil*

Brief description of the complaint, if any/ Ggf. kurze Beschreibung der Beschwerde

Please add photos/Bitte Fotos hinzufügen

All this info may be emailed to classico-service@telluria.eu/Alle diese Informationen können per E-Mail an classico-service@telluria.eu gesendet werden.



KLACHTENFORMULIER FORMULAIRE DE RECLAMATION

Voornaam klant/Prénom client

Naam klant/Nom client

Adres/Adresse

Gemeente/Ville

Tel.

Mail

Ordernummer/Numéro d'ordre*

** dit nummer vindt u op de stuklijst, alsook op de verpakingskist/ce numéro se trouve sur la liste des pièces ainsi que sur la boîte d'emballage.*

Datum van ontvangst/Date de réception

**Datum waarop de klacht ontdekt werd/
Date à laquelle la plainte a été découverte**

Beschadigd onderdeel/Pièce endommagé*

** u vindt het artikelnummer terug op de stuklijst/vous trouverez le numéro d'article sur la liste des pièces*

Ontbrekend onderdeel/Pièce manquante*

Eventueel korte omschrijving van de klacht/ Eventuellement une brève description de la plainte

Graag foto's toevoegen/Veuillez ajouter des photos

Al deze info mag gemaild worden naar classico-service@telluria.eu/Toutes ces informations peuvent être envoyées par email à classico-service@telluria.eu.