

# CHAMBERY PANADERO



## MAßE

MAßE H x B x T	755x629x478 mm
GEWICHT BRUTTO/NETTO	113/98 kg
MAßE FEUERRAUMTÜR	482x351 mm
DURCHMESSER DES ABGASSTUTZEN	Ø 150-153 mm Hinten
GLASDIAGONALE	600 mm

## EIGENSCHAFTEN

ROST UND TÜR AUS GUSSEISEN	
NENNLEISTUNG	7,4 KW
WIRKUNGSGRAD	80,7 %
CO – EMISSIONEN	0,12 %
HITZESCHUTZANSTRICH	800°C
GLASKERAMIKSCHEIBE HITZEBESTÄNDIG BIS	750°C

EAN 8426964186703  
REF. 18670

## PRODUKT PLUS

### ECODESIGN

-  RAUMHEIZVERMÖGEN
-  SCHEIBENSPÜLUNG
-  DREIFACHVERBRENNUNG
-  SCHEITLÄNGE 50 CM
-  DOPPELBLECHGEHÄUSE  
4 + 4 MM

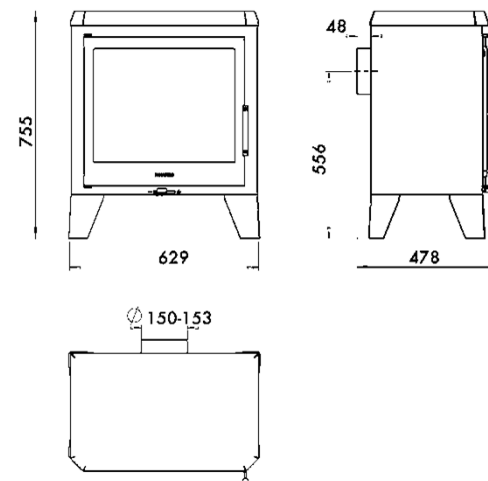

CHAMBERY DE