

TOPAZE

PANADERO



MAßE

MAßE H x B x T	788x567x482 mm
GEWICHT BRUTTO/NETTO	106/91 kg
MAßE FEUERRAUMTÜR	479x351 mm
DURCHMESSER DES ABGASSTUTZEN	Ø 150-153 mm Hinten
GLASDIAGONALE	600 mm

EIGENSCHAFTEN

ROST UND TÜR AUS GUSSEISEN	
NENNLEISTUNG	7,4 KW
WIRKUNGSGRAD	80,7 %
CO – EMISSIONEN	0,12 %
HITZESCHUTZANSTRICH	800°C
GLASKERAMIKSCHEIBE HITZEBESTÄNDIG BIS	750°C

EAN 84269641868826
REF. 18682

PRODUKT PLUS

ECODESIGN

-  RAUMHEIZVERMÖGEN
-  SCHEIBENSPÜLUNG
-  DREIFACHVERBRENNUNG
-  SCHEITLÄNGE 50 CM
-  DOPPELBLECHGEHÄUSE
4 + 3 MM

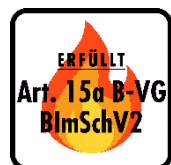
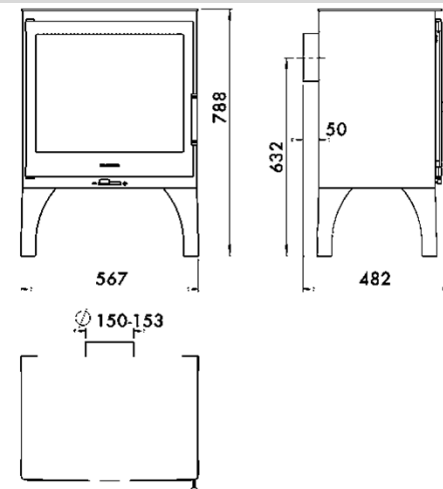

TOPAZE DE