

109302

6W LED / 6W Total
incl.LED Board:QL7001431
110-240V~ 50/60Hz

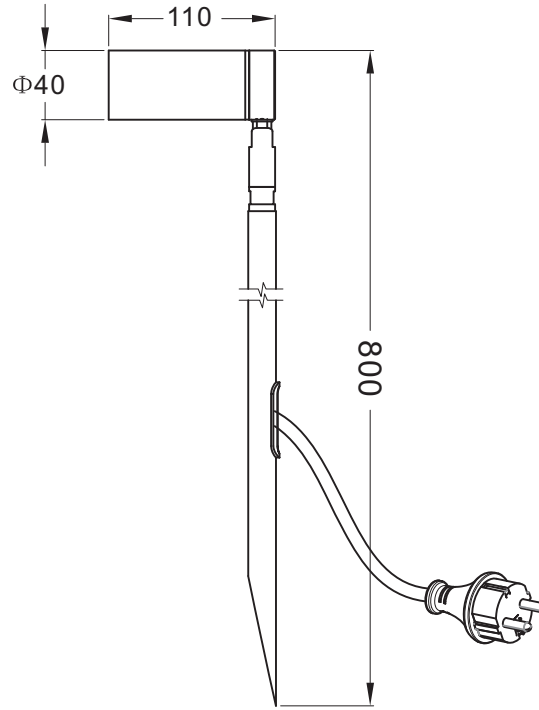

Unit of measure/ Maßeinheit/ Unité de mesure: mm

(EN) Intended use (DE) Bestimmungsgemäße Verwendung	
(FR) Utilisation conforme (NL) Beoogd gebruik (PL) Stosowanie zgodnie z przeznaczeniem (NO) Riktig bruk (DK) Korrekt brug (SE) Avsedd användning (FI) Määräystenmukainen käyttö (IT) Impiego appropriato (ES) Uso prescrito (CZ) Použití v souladu s určením (PT) Utilização correta (GR) Ενδεδειγμένη χρήση (SK) Predpokladané použitie (EE) Eeldatav kasutus (LV) Paredzams lietojums (LT) Numatomas naudojimas (RO) Utilizare intenționată (SI) Predvidena uporaba (HR) Namjenska upotreba (HU) Tervezett felhasználás (BG) предназначена употреба (AL) Përdorimi i parashikuar (MK) Предвидена употреба (TR) Amaçlı kullanım (UK) Призначене використання (BA,ME,RS) Namjenska upotreba	
(GB) Portable light for use outdoors on paths or in flowerbeds	(DE) Ortsveränderliche Verwendung an Wegen/in Beeten im Außenbereich
(FR) Pose amovible le long des allées/des parterres de plantes, à l'extérieur	(NL) Verplaatsbaar en te gebruiken langs paden en bloembedden buitenshuis
(PL) Do montażu przenośnego na zewnątrz przy drogach/grządkach	(NO) Transportabel bruk på veier og i bedd utendørs
(DK) Transportabel brug på veje og i bed udendørs	(SE) Bärbar användning vid stigar/rabatter utomhus
(FI) Paikasta riippumaton käyttö ulkotilojen kulkureiteillä/kukkapenkeissä	(IT) Impiego mobile su sentieri/aiuole in ambienti esterni
(ES) Empleo ambulante en caminos / jardineras en el exterior	(CZ) Mobilní použití u cestiček / v záhonech v exteriéru
(PT) Aplicação móvel para caminhos/ canteiros em exteriores	(GR) Κινητή χρήση σε διαδρόμους/παρτέρια σε εξωτερικό χώρο
(SK) Prenosné svetlo na použitie vonku na cestách alebo v záhonech	(BG) Преносима светлина за използване на открито на пътеки или в цветни лехи
(EE) Kaasaskantav valgusti kasutamiseks õuealal radadel või lillepeenardes	(LV) Pārnēsājama gaisma izmantošanai ārpus telpām uz ceļiņiem vai puķu dobēs
(LT) Nešiojamas šviestuvas, skirtas naudoti lauke ant takų ar gėlynuose	(RO) Lumină portabilă pentru utilizare în exterior pe alei sau în straturile de flori
(SI) Prenosna luč za uporabo na prostem na poteh ali cvetličnih gredah	(HR) Prijenosna svjetiljka za korištenje vani na stazama ili u gredicama
(HU) Hordozható fény kültéri használatra utakon vagy virágágyásokban	(AL) Dritë portative për përdorim jashtë në rrugë ose në kopshte
(MK) Преносна светлина за надвор на патеки или во цветни градини	(TR) Yollarda veya çiçek yataklarında kullanılan taşınabilir ışık
(UK) Портативне світло для використання на вулицях або в квіткових клумбах	(BA) Prenosno svjetlo za upotrebu na stazama ili u cvjetnjacima
	(ME)
	(RS)

(EN) Package contents		
(DE) Lieferumfang (FR) Contenu de la livraison (NL) Bij de levering inbegrepen (PL) Zakres dostawy (NO) Levering (DK) Leveringsomfang (SE) Leveransomfattning (FI) Toimitussisältö (IT) Fornitura (ES) Volumen de suministro (CZ) Rozsah dodávky (PT) Material fornecido (GR) Παράδοτος εξοπλισμός (SK) Obsah balenia (EE) Pakendi sisu (LV) Pakas saturs (LT) Pakuotės turinys (RO) Conținutul pachetului (SI) Vsebina paketa (HR) Sadržaj paketa (HU) A csomag tartalma (BG) обхват на доставката (AL) Përbajtja e dorëzimit (MK) Содржина на испорака (TR) Teslimat içeriği (UK) Зміст доставки (BA,ME,RS) Sadržaj isporuke		
(GB) 1 Ground spike light Installation hardware Mounting instructions	(DE) 1 Spießleuchte Montagematerial Montageanleitung	(FR) 1 Lampe à piquer en terre Matériel de montage Instructions de montage
(NL) 1 Prikspot Monteringsmateriale Montagehandleiding	(PL) 1 Lampa z grotem ziemnym Elementy montażowe Instrukcja montażu	(NO) 1 Lampe med spyd Monteringsmateriale Brukerveiledning
(DK) 1 Lampe med spyd Monteringsmateriale Brugervejledning	(SE) 1 Markspett Monteringsmaterial Monteringsanvisning	(FI) 1 Maapiikki Asennus materiaali Asennusohjeet
(IT) 1 Picchetto Materiale di montaggio Istruzioni di montaggio	(ES) 1 Estaca Material de montaje Instrucciones de montaje	(CZ) 1 Zapichovací svítidlo Materiál pro montáž Návod k montáži
(PT) 1 Luminária tipo espeto Material de montagem Instruções de montagem	(GR) 1 Πάβδος γείωσης Υλικό συναρμολόγησης Οδηγίες συναρμολόγησης	(SK) 1 svetlo s hrotom na zem Inštalčný hardvér Inštalčná príručka
(BG) 1 Светлина за заземяване на шипове материали за монтаж инструкции за монтаж	(EE) 1 maapealne valgusti Paigaldustarvikud Paigaldusjuhend	(LV) 1 zemes smailes gaisma Instalācijas aparatūra Uzstādīšanas instrukcija
(LT) 1 žemės smaigalio šviestuvus Montavimo aparatinė įranga Montavimo instrukcija	(RO) 1 Lampă cu vârf de pământ Hardware de instalare Instrucțiuni de montare	(SI) 1 svetilka za prižiganje na tleh Namestitvena strojna oprema Navodila za montažo
(HR) 1 Šiljasto svjetlo za tlo Instalacijski hardver Upute za montažu	(HU) 1 földi tűskés lámpa Telepítési hardver Szerelési útmutató	(AL) 1 Dritë për tokë Materiali i montimit Udhëzuesi i montimit
(MK) 1 Светло за земја Монтажен материјал Упатство за монтажа	(TR) 1 Zemin ışığı Montaj malzemesi Montaj kılavuzu	(UK) 1 Земельний прожектор Монтажний матеріал Інструкція з монтажу
(BA) 1 Svjetlo za zemlju (ME) Montažni materijal (RS) Uputstvo za montažu		

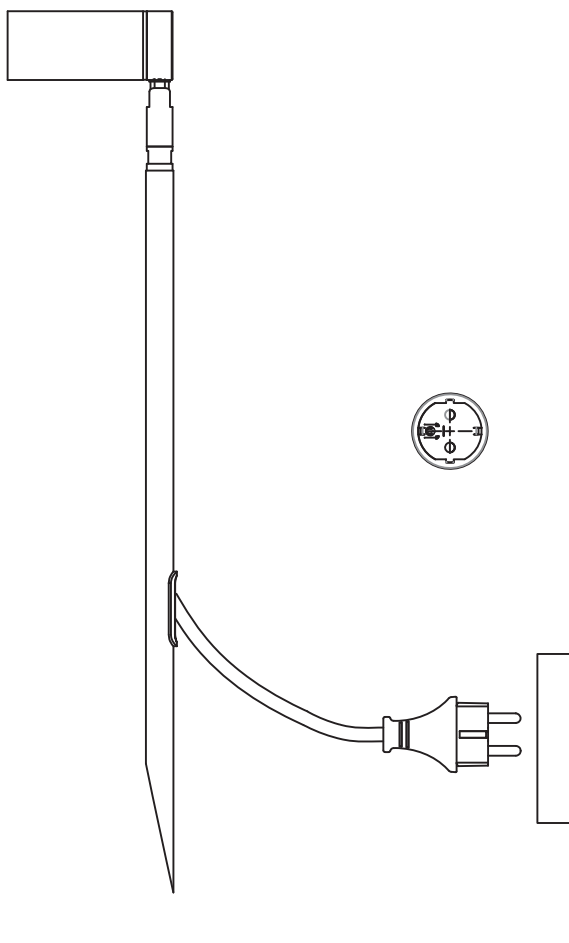
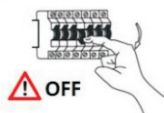

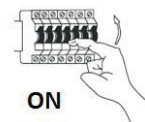

Spike led spot light
incl.LED QL7001431
380lm Module
260lm Lamp
6W LED Module
6W Lamp
110V-240~ 50/60Hz
3000K
CRI>80
20000 h
10000 ON/OFF

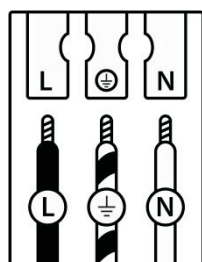

	(EN)	(DE)	(FR)	(NL)	(PL)	(NO)
L	Live conductor	Stromführender Leiter	Conducteur	Spanningvoerende draad	Przewód prądowy	Strømførende leder
	Earth conductor	Schutzleiter	Conducteur de protection (terre)	Aardkabel	Przewód uziemiający	Jordledningen
N	Neutral conductor	Neutralleiter	Conducteur neutre	Nulleider	Przewód zerowy	Nøytralleider

	(DK)	(SE)	(FI)	(IT)	(ES)	(CZ)
L	Strømførende leder	Strömförande ledare	Virtajohdin	Conduttore sotto tensione	Conductor de corriente	Vodič pod napětím
	Jordledningen	Skyddsledare	Suojajohdin	Conduttore di terra	Conductor de protección	Ochranný vodič
N	Neutralleider	Neutralledare	Nollajohdin	Conduttore neutro	Conductor neutro	Neutrální vodič



	(PT)	(GR)	(SK)	(EE)	(LV)	(LT)
L	Condutor vivo	Ρευματοφόρος αγωγός	Živý vodič	Faasijuht	Dzīvais vadītājs	Gyvas dirigentas
	Condutor de terra	Αγωγός γείωσης	Zemný vodič	Maandusjuht	Zemes vadītājs	Žemės dirigentas
N	Condutor neutro	Ουδέτερος αγωγός	Neutrálny vodič	Neutraaljuht	Neitrālais vadītājs	Neutrinis dirigentas

	(RO)	(SI)	(HR)	(HU)	(BG)	(AL)
L	Conductor viu	Živi dirigent	Živi dirigent	Élő vezető	проводник под напряжение	Kondaktor i gjallë
	Conductor de împământare	Zemeljski dirigent	Uzemljeni dirigent	Földvezető	защитен проводник	Dirigjent i tokës
N	Conductor neutru	Neutralni dirigent	Neutralni dirigent	Semleges vezető	нулев проводник	Kondaktor neutral

	(MK)	(TR)	(UK)	(BA)(ME)(RS)
L	Жив кондуктор	Canlı yönetici	Живий диригент	Živi dirigent
	Земјен проводник	Toprak iletkeni	Земельний провідник	Zemaljski provodnik
N	Неутрален проводник	Nötr iletken	Нейтральный провідник	Neutralni provodnik

(EN) Safety Precautions

(DE) Verwendete Symbole | (FR) Symboles utilisés | (NL) Gebruikte symbolen | (PL) Stosowane symbole | (NO) Brukte symboler | (DK) Brugte symboler | (SE) Använda symboler | (FI) Käytetyt symbolit | (IT) Simboli usati | (ES) Símbolos empleados | (CZ) Použité symboly | (PT) Símbolos utilizados | (GR) Χρησιμοποιούμενα σύμβολα | (SK) Bezpečnostné opatrenia | (EE) Ohutusabinõud | (LV) Drošības pasākumi | (LT) Saugos priemonės | (RO) Măsuri de precauție | (SI) Varnostni ukrepi | (HR) Mjere opreza | (HU) Használt szimbólumok | (BG) Мерки за безопасност | (AL) Simbolet e përdorura | (MK) Користени симболи | (TR) Kullanılan semboller | (UK) Використовувані символи | (BA,ME,RS) Korišteni simboli

IP65

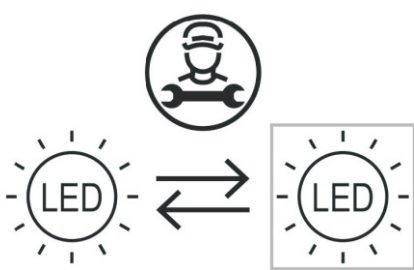

<p>(EN) This product contains a light source of energy efficiency class G (DE) Dieses Produkt enthält eine Lichtquelle der Energieeffizienzklasse G (FR) Ce produit comprend une source de lumière de classe d'efficacité énergétique G (NL) Dit product bevat een lichtbron van energie-efficiëntieklasse G (PL) Produkt ten zawiera źródło światła o klasie efektywności energetycznej G (NO) Dette produktet inneholder en lyskilde i energieeffektivitetsklasse G (DK) Dette produkt indeholder en lyskilde af energieeffektklasse G (SE) Denna produkt innehåller en ljuskälla i energieffektivitetsklass G (FI) Tämä tuote sisältää energiatehokkuusluokan G valonlähteen (IT) Questo prodotto contiene una sorgente luminosa della classe di efficienza energetica G (ES) Este producto contiene una fuente de luz de la clase de eficiencia energética G (CZ) Tento výrobek obsahuje světelný zdroj třídy energetické účinnosti G (PT) Este produto contém uma fonte de luz da classe de eficiência energética G (GR) Αυτό το προϊόν περιέχει μια φωτεινή πηγή ενεργειακής απόδοσης κλάσης G (SK) Tento výrobok obsahuje zdroj svetla triedy energetickej efektivity G (EE) See toode sisaldab energiatõhususklassi G valgusallikat (LV) Šis produkts satur enerģijas efektivitātes klases G gaismas avotu (LT) Šis gaminys turi energijos efektyvumo klasės G šviesos šaltinį (RO) Acest produs conține o sursă de lumină de clasă de eficiență energetică G (SI) Ta izdelek vsebuje svetlobni vir energijskega razreda G (HR) Ovaj proizvod sadrži izvor svjetlosti energetske učinkovitosti klase G (HU) Ez a termék egy G energiahatékonysági osztályú fényforrást tartalmaz (BG) Този продукт съдържа източник на светлина с клас на енергийна ефективност: G (AL) Ky produkt përmban një burim drite të klasës së efikasitetit të energjisë G (MK) Овој производ содржи извор на светлина од класа на енергетска ефикасност G (TR) Bu ürün, enerji verimliliği sınıfı G olan bir ışık kaynağı içerir (UK) Цей продукт містить джерело світла класу енергоефективності G (BA)(ME)(RS) Ovaj proizvod sadrži izvor svjetlosti energetske klase G</p>	<p>QR</p> 	<p>EAN</p> <p>8718881178306</p>
--	---	---------------------------------

	<p>(EN) Replaceable (LED only) light source by a professional. (DE) Durch einen Fachmann austauschbare Lichtquelle (nur LED). (FR) Source de lumière remplaçable (LED uniquement) par un professionnel. (NL) Lichtbron (alleen led) te vervangen door een professional. (PL) Wymienne (tylko LED) źródło światła wykonane przez profesjonalistę. (NO) Utskiftbar (kun LED) lyskilde av en profesjonell. (DK) Udskiftelig lyskilde (kun LED), udskiftes af en elektriker. (SE) Ljuskälla (endast LED) utbytbar genom fackman. (FI) Ammattilainen voi vaihtaa vaihdettavan (vain LED) valonlähteen. (IT) Sorgente luminosa (solo LED) sostituibile da un professionista. (ES) Fuente de luz (solo LED) sustituible por un profesional. (CZ) Vyměnitelný (pouze LED) světelný zdroj odborníkem. (PT) Luz LED (apenas LED) substituível por um profissional. (GR) Η πηγή φωτός (μόνο LED) να αντικαθίσταται από επαγγελματία. (SK) Zdroj svetla (iba LED) vymeniteľný prostredníctvom odborníka. (EE) Spetsialisti poolt vahetatav valgusallikas (ainult LED). (LV) Speciālista maināms gaismas avots (tikai LED). (LT) Specialisto keičiamas šviesos šaltinis (tik LED). (RO) Sursă de lumină schimbabilă de către un specialist (doar LED). (SI) Svetlobni vir, ki ga lahko zamenja strokovnjak (samo LED). (HR) Izvor svjetlosti koji može zamijeniti stručnjak (samo LED). (HU) Szakember által cserélhető (csak LED) fényforrás. (BG) Светлинен източник, който може да се смени от специалист (само LED). (AL) Burim drite i zëvendësueshëm (LED vetëm) nga një profesionist. (MK) Изворот на светлина (само LED) се заменува од професионалец. (TR) Değiştirilebilir (yalnızca LED) ışık kaynağı bir profesyonel tarafından değiştirilir. (UK) Замінний (тільки LED) джерело світла замінюється фахівцем. (BA)(ME)(RS) Zamjenjiv (samo LED) izvor svjetlosti zamjenjuje profesionalac.</p>
---	--

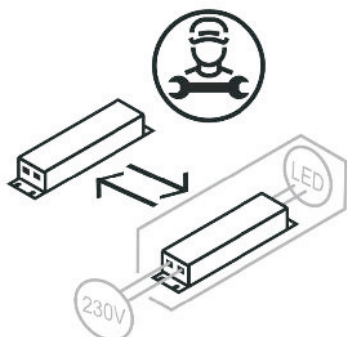

- (EN) Replaceable control gear by a professional.
 (DE) Durch einen Fachmann austauschbares Betriebsgerät.
 (FR) Contrôleur remplaçable par un professionnel.
 (NL) Voorschakelapparatuur te vervangen door een professional.
 (PL) Wymienny układ sterujący przez profesjonalistę.
 (NO) Utskiftbar kontrollutstyr av en profesjonell.
 (DK) Udskiftelig igangsætter, udskiftes af en elektriker.
 (SE) Styrdon utbytbart genom fackman.
 (FI) Ammattilainen voi vaihtaa vaihdettavat ohjauslaitteet.
 (IT) Dispositivo di controllo sostituibile da un professionista.
 (ES) Dispositivo de control sustituible por un profesional.
 (CZ) Vyměnitelný předřadník odborníkem.
 (PT) Dispositivo de controlo substituível por um profissional.
 (GR) Ο εξοπλισμός ελέγχου να αντικαθίσταται από επαγγελματία.
 (SK) Predradník vymeniteľný prostredníctvom odborníka.
 (EE) Spetsialisti poolt vahetatav juhtseade.
 (LV) Speciālista maināma vadības iekārta.
 (LT) Specialisto keičiamas valdymo įrenginys.
 (RO) Aparat de comandă schimbabil de către un specialist.
 (SI) Nadomestna krmilna naprava, ki jo lahko zamenja strokovnjak.
 (HR) Zamjenjivi upravljački sklop koji može zamijeniti stručnjak.
 (HU) Szakember által cserélhető vezérlőszerkezet.
 (BG) Уред, който може да се смени от специалист.
 (AL) Pajisje kontrolli e zëvendësueshme nga një profesionist.
 (MK) Заменлива контролна опрема од страна на професионалец.
 (TR) Profesyonel tarafından değiştirilebilir kontrol donanımı.
 (UK) Замінний контрольний пристрій фахівцем.
 (BA)(ME)(RS) Zamjenjiva kontrolna oprema od strane profesionalca.