

**INSTRUCTION MANUAL/BEDIENUNSANLEITUNG/NOTICE D'UTILISATION/
MANUAL DE INSTRUCCIONES DE USO/MANUALE DI ISTRUZIONI**

! WARNING!

Adults assembly required.
During assembly, keep all parts away from children.
Check regularly to ensure all fasteners are tight.

! WARNUNG!

Die Montage ist von Erwachsenen durchzuführen.
Halten Sie während der Montage alle Teile von Kindern fern.
Überprüfen Sie regelmäßig den festen Sitz der Schrauben.

! Attention!

Montage à effectuer par des adultes.
Pendant le montage, tenez les éléments éloignés des enfants.
Vérifiez régulièrement que toutes les vis soient serrées.







! ¡Atención!

Se requiere que el montaje sea llevado a cabo por un adulto.
Durante el montaje, mantenga todas las piezas fuera del alcance de los niños.
Verifique regularmente que todos los tornillos estén correctamente apretados.

! Avvertimento!

L'assemblaggio deve essere effettuato da adulti.
Durante il montaggio mantenere tutti i pezzi lontano dalla portata dei bambini.
Controllare regolarmente per assicurarsi che tutte le chiusure siano ben strette.

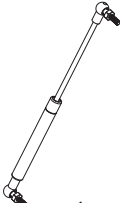
PARTS LIST/STÜCKLISTE/PARTS LIST/LISTA DE PIEZAS/LISTA DEI PEZZI

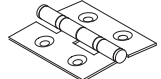
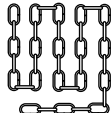
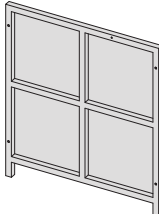
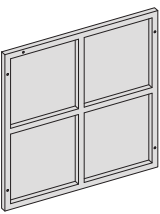
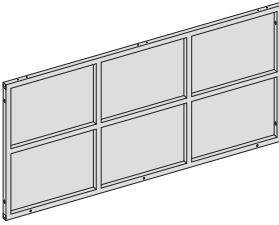
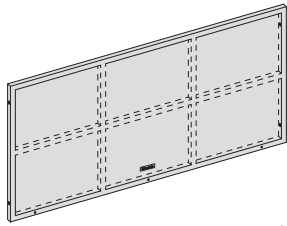
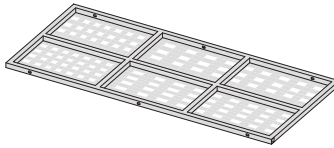
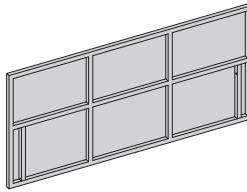
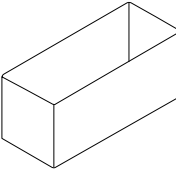
<p>A</p>  <p>M6x40 14pcs</p>	<p>B</p>  <p>M4x16 7pcs</p>	<p>M</p>  <p>1pc</p>	<p>C</p>  <p>M6 14pcs</p>	<p>D</p>  <p>12MM 2pcs</p>	<p>E</p>  <p>1pc</p>	<p>D1</p>  <p>12MM 1pc</p>
<p>D2</p>  <p>EN: pre-assembled DE: vormontiert FR: préassemblée ES: Preensamblado IT: preassemblato</p> <p>50x35mm 3pcs</p>		<p>D3</p>  <p>EN: pre-assembled DE: vormontiert FR: préassemblée ES: Preensamblado IT: preassemblato</p> <p>240mm 1pc</p>		<p>F</p>  <p>505x610mm 1pc</p>	<p>G</p>  <p>505x610mm 1pc</p>	<p>H</p>  <p>1125x555mm 1pc</p>
<p>I</p>  <p>1125x555mm 1pc</p>		<p>J</p>  <p>1065x555mm 1pc</p>		<p>K</p>  <p>1165x545mm 1pc</p>	<p>L</p>  <p>1050x460x530mm 1pc</p>	

ASSEMBLY/MONTAGE/ASSEMBLAGE/MONTAJE/ASSEMBLAGGIO

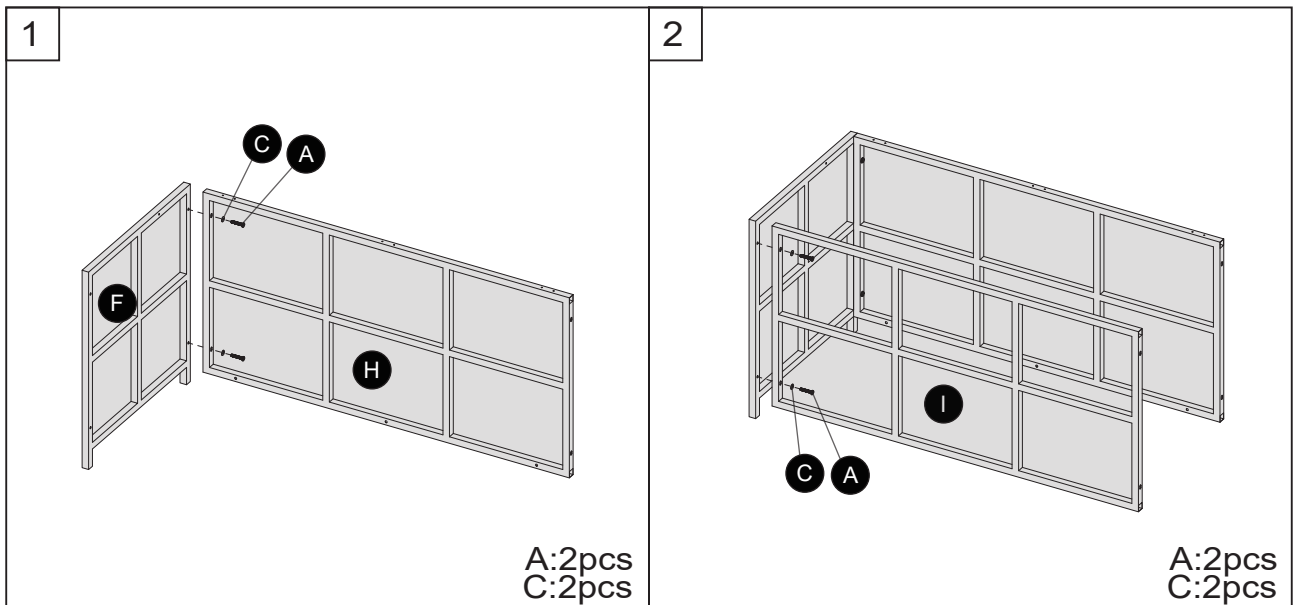

**RETAIN FOR FUTURE REFERENCE
FÜR KÜNFTIGE VERWENDUNG AUFBEWAHREN
A CONSERVER POUR UNE UTILISATION FUTURE
CONSERVAR PARA SER LEÍDO POR CADA NUEVO USUARIO
ANTES DE UTILIZAR EL ARTÍCULO POR PRIMERA VEZ
CONSERVARE PER CONSULTAZIONI FUTURE**



Warning!
Warnung!
Attention !
Atención!
Avvertimento!

Tight all the screws to 60% first then tight to 100%.
Während der Montage alle Schrauben zuerst 60% anziehen, dann zu 100%.
Serrez toutes les vis à 60% d'abord puis serrez à 100%.
Primero apriete los tornillos al 60% y después al 100%.
Stringere le viti dapprima al 60% e successivamente completamente al 100%.

3

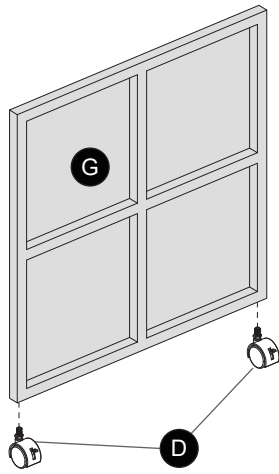

D:2pcs

4

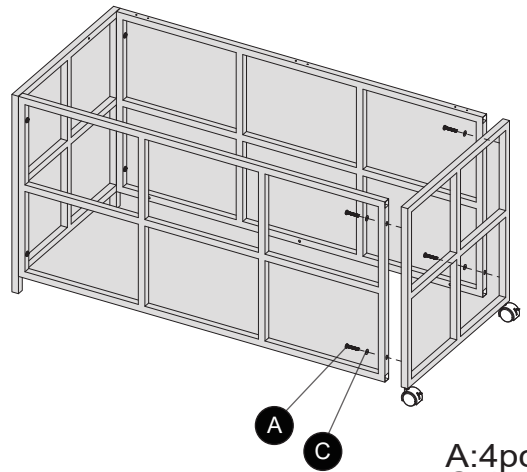

A:4pcs
C:4pcs

5

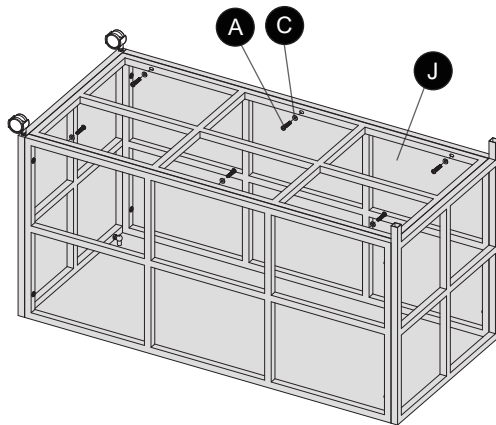

A:6pcs
C:6pcs

6

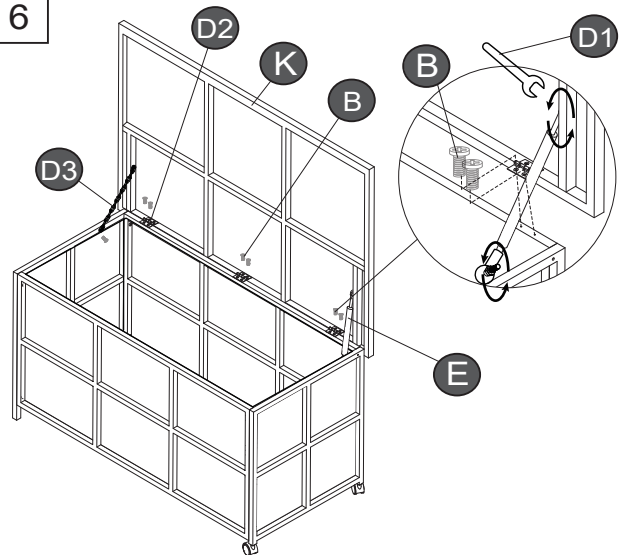

B:7pcs

7

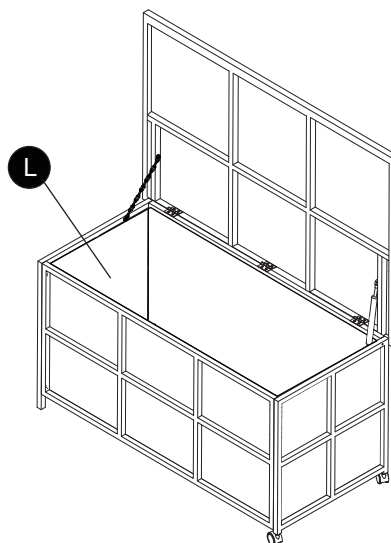

Contact person
tectake Ltd.
Mappin House
4 Winsley Street
W1W 8HF London ,UK
Telephone: +44 203488 4565
www. tectake.co.uk
mail@tectake.co.uk

Ansprechpartner
tectake GmbH
Tauberweg 41
97999 Igersheim
Telefon: +49 7931 991 920
www.tectake.de
E-Mail: verkauf@tectake.de

Personne de contact
Made4Home SAS
137 av. Gustave Eiffel
ZI Rognac Nord
13340 Rognac (France)
téléphone au: +33 4 42 81 81 80
www.tectake.fr
E-Mail: contact@tectake.fr

Persona de contacto
Ibérica de Distribuciones online del Hogar,
SLU,
Méndez Álvaro 20,
Madrid 28045,
Teléfono: +34 912907933
www.tectake.es
correo electrónico: mail@idoh.es

Persona di contatto
tenulodi S.r.l.
Via Manzano 70
33040 Premariacco (UD)
Numero di telefono: +39 0471 1800175
www.tectake.it
E-Mail: mail@tectake.it

Kontaktní osoba
TecTake s.r.o.
se sídlem na adrese Lidická 700 / 19, Veverčí,
602 00 Brno, Česká republika
+420 538 880 441
www.tectake.cz
E-Mail: mail@tectake.cz