

# INSTRUCTION MANUAL

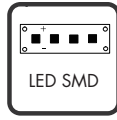

## Climo Square CL Black Smart 105773

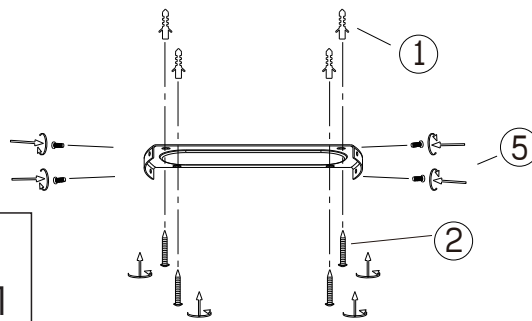
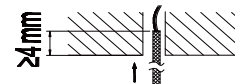
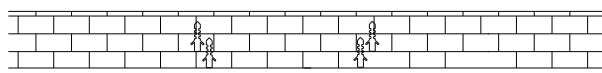
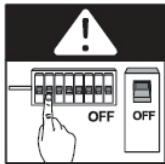

Ceiling Fan lamp  
incl. LED QL7001231  
4x1020lm Module  
1300lm Lamp  
4x9.9W LED Module  
40W Lamp  
220-240V~50Hz  
3000-6500-4000K  
CRI > 80  
30000 h  
15000 ON/OFF

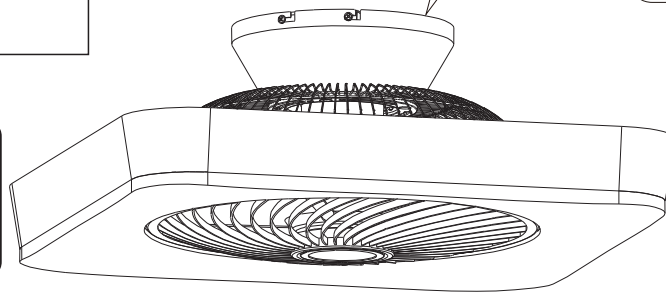
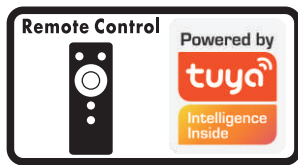
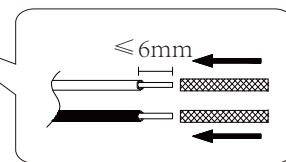
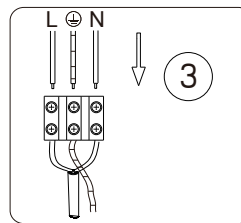

Overall Sizes:

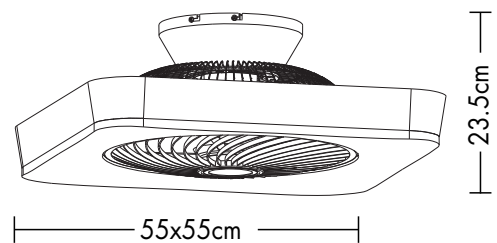
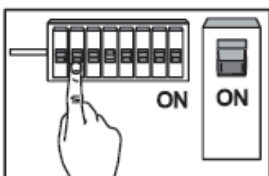

**FitinQ B.V.**

Smaragdweg 52, 5527 LB Hapert, The Netherlands  
www.qazqa.nl

QAZQA

# 105773

4x 9.9W LED

incl. LED Board: QL7001231

220-240V~50Hz

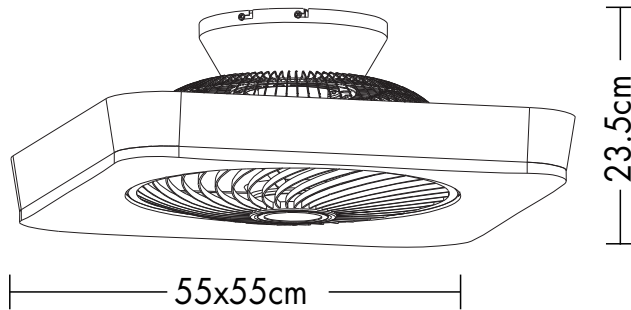

	QR	EAN
<p>(DE) Dieses Produkt enthält eine Lichtquelle der Energieeffizienzklasse F (EN) This product contains a light source of energy efficiency class F (FR) Ce produit comprend une source de lumière de classe d'efficacité énergétique F (NL) Dit product bevat een lichtbron van energie-efficiëntieklasse F (PL) Produkt ten zawiera źródło światła o klasie efektywności energetycznej F (NO) Dette produktet inneholder en lyskilde i energieeffektivitetsklasse F (DK) Dette produkt indeholder en lyskilde af energieeffektklasse F (SE) Denna produkt innehåller en ljuskälla i energieffektivitetsklass F (FI) Tämä tuote sisältää energiatehokkuusluokan F valonlähteen (IT) Questo prodotto contiene una sorgente luminosa della classe di efficienza energetica F (ES) Este producto contiene una fuente de luz de la clase de eficiencia energética F (CZ) Tento výrobek obsahuje světelný zdroj třídy energetické účinnosti F (PT) Este produto contém uma fonte de luz da classe de eficiência energética F (GR) Αυτό το προϊόν περιέχει μια φωτεινή πηγή ενεργειακής απόδοσης κλάσης F (SK) Tento výrobok obsahuje zdroj svetla triedy energetickej efektivity F</p>		8718881141119

	<p>(DE) Durch einen Fachmann austauschbare Lichtquelle (nur LED) (EN) Replaceable (LED only) light source by a professional. (FR) Source de lumière remplaçable (LED uniquement) par un professionnel. (NL) Lichtbron (alleen led) te vervangen door een professional. (PL) Wymienne (tylko LED) źródło światła wykonane przez profesjonalistę. (NO) Utskiftbar (kun LED) lyskilde av en profesjonell. (DK) Udskiftelig lyskilde (kun LED), udskiftes af en elektriker. (SE) Ljuskälla (endast LED) utbytbar genom fackman. (FI) Ammattilainen voi vaihtaa vaihdettavan (vain LED) valonlähteen. (IT) Sorgente luminosa (solo LED) sostituibile da un professionista.I (ES) Fuente de luz (solo LED) sustituible por un profesional. (CZ) Vyměnitelný (pouze LED) světelný zdroj odborníkem. (PT) Luz LED (apenas LED) substituível por um profissional. (GR) Η πηγή φωτός (μόνο LED) να αντικαθίσταται από επαγγελματία. (SK) Zdroj svetla (iba LED) vymeniteľný prostredníctvom odborníka.</p>
--	--

	<p>(DE) Durch einen Fachmann austauschbares Betriebsgerät. (EN) Replaceable control gear by a professional. (FR) Contrôleur remplaçable par un professionnel. (NL) Voorschakelapparaat te vervangen door een professional. (PL) Wymienny układ sterujący przez profesjonalistę. (NO) Utskiftbar kontrollutstyr av en profesjonell. (DK) Udskiftelig igangsætter, udskiftes af en elektriker. (SE) Styrdon utbytbar genom fackman. (FI) Ammattilainen voi vaihtaa vaihdettavat ohjauslaitteet. (IT) Dispositivo di controllo sostituibile da un professionista. (ES) Dispositivo de control sustituible por un profesional. (CZ) Vyměnitelný předřadník odborníkem. (PT) Dispositivo de controlo substituível por um profissional. (GR) Ο εξοπλισμός ελέγχου να αντικαθίσταται από επαγγελματία. (SK) Predradník vymeniteľný prostredníctvom odborníka.</p>
--	--

**FitinQ B.V.**

Smaragdweg 52, 5527 LB Hapert, The Netherlands  
www.qazqa.nl

QAZQA

# CONNECTION MANUAL

## 1. REMOTE CONTROL

The remote control included with the lamp is already connected and ready to use once the batteries are installed.

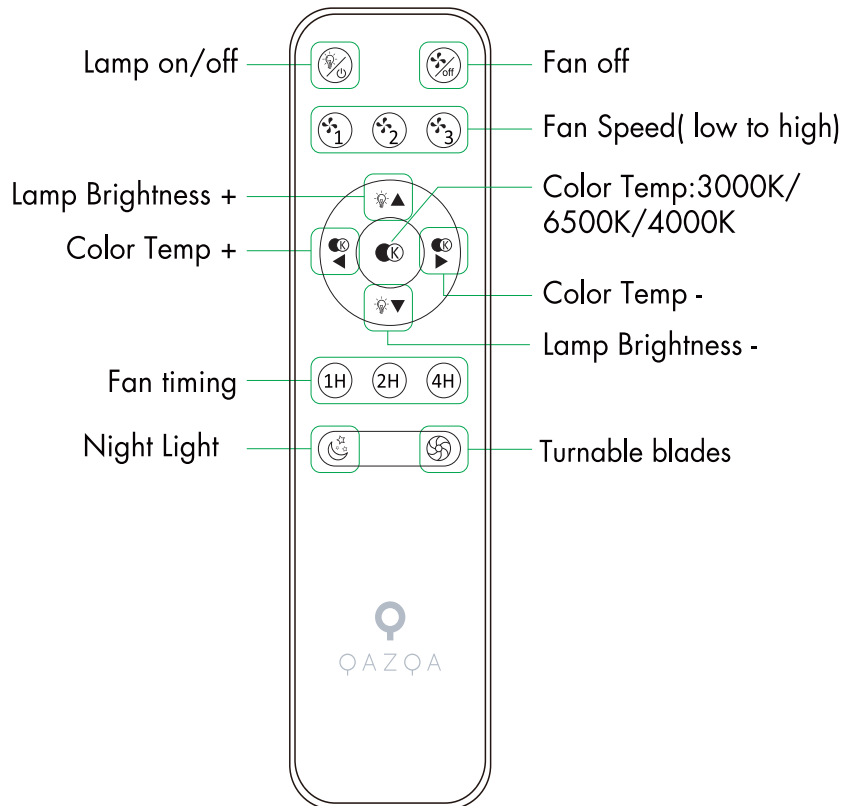

## 2. APP TUYA SMART PREPARATION

- Connect the mobile phone to the Wi-Fi network. (2.4GHz band)

- Download "Tuya APP". Available in IOS and Android or scan the attached QR code.

if you are a new APP user, you can register by clicking the "Register" button and following the registration instructions. If you already have an account registered under "Tuya", you can access the login page by clicking on the "Login with an existing username" button.



### HOW TO CONFIGURE THE LIGHTING FIXTURE

1. First network configure: After the Fan lamp is powered on, it needs to be paired with the network for the first time. Once the Fan lamp is powered on, it will blink. And then turn on the Bluetooth on the mobile phone, wait a few seconds, the device will pop up in the App, then follow the App prompts to connect the network.

The lighting fixture stops flashing. The mobile App and remote control can control the Fan lamps at the same time

2. When the Fan lamp have to reconfigure the network with TUYA Smart, it needs to turn on/off at the wall switch for three times (switch on or off once every second), the Fan lamp will blink, access the pairing state, turn on the Bluetooth at the mobile phone, wait a few seconds, the device will pop up in the App, and then configure the network according to the App prompt.

1. If the pairing is successful, the Fan lamp will be stop flashing, the mobile phone and remote control will be controlled at the same time.

2. If not matched, the Fan lamp will be blink for one minute and stop blinking by itself. The Fan lamp can be controlled by remote only.

3. The fan lamp with the air guide wheel can be controlled by remote only, and the Tuya smart app cannot control the air guide wheel.

Note: Do not operate the remote control while the Fan lamp has been flashing process, otherwise the pairing will be fail, repeat the steps

### HOW TO LINK THE LIGHTING FIXTURE IF THE LIGHT FLASHES RAPIDLY:

(1) Start the application, click "Add Device" or "+" in the upper right corner of the screen.

(2) Select "Small Home Appliances" on the device list page, then "Fan Devices(Wi-Fi)".

(3) Click the orange button confirming that the fan flashes quickly.

(4) Select your Wi-Fi connection. Enter your Wi-Fi password and click "Confirm" to proceed to the next step.

(5) At this point the fan will attempt to connect to your wi-fi network.

(6) If the fan connects correctly, simply click the "Done" button. But first it would be convenient to "rename" the fan as you wish(e.g. Bedroom).

## FittinQ B.V.

Smaragdweg 52, 5527 LB Hapert, The Netherlands  
www.qazqa.nl



# SAFETY INSTRUCTION

Please study the instruction manual and below information carefully before installing or using this product.  
Please keep this user manual for further reference

1. The luminaires may only be installed by authorized and qualified technicians according the valid regulations for electrical installation.
2. Maintenance of the luminaires is limited to their surfaces. During maintenance no moisture can come into contact with any areas of the terminal connections or voltage control parts.
3. The electrical supply must be switched off at the outset, preferably by means of a switch in the distribution box, before any installation, maintenance or repair work is undertaken.
4. Exterior lighting must not be installed during rain.
5. Take account of the minimal separation distance from other objects and the room required around the fitting.
6. If in any doubt, consult a professional, taking local installation requirements into account. Some countries stipulate that lighting may be installed only by registered installers.
7. Clamping screws in electrical connections must be adequately tightened. This is particularly the case with 12V low voltage conductors.
8. Clean with a clean, dry cloth or brush, use no solvents or abrasives. Avoid dampness on all electrical components
9. Take account of all available technical information.
10. Meaning of symbols:



For indoor use only, where direct contact with water is impossible



This icon indicates the level of water-proof and dust-proof



Protection Class I: the fitting must be earthed



Protection Class II: the fitting is doubled insulated and does not require earthing



Protection Class III: the fitting is low voltage



Minimum distance from lighted objects (meters)



The type of lamp and maximum size and wattage indicated in each lighting unit must not be exceed; different items require different kind of light sources with different bulb icons



The armature is designed to work only with the indicated voltage. Different items require different working voltage.



The luminaire can be used in combination with a dimmer



The reference light angle and light space of the luminaire



This luminaire cannot be disposed together with normal domestic waste in standard rubbish can, but you have to bring it to a staging area for electrical waste

11. Take note of the symbols when connecting wires:

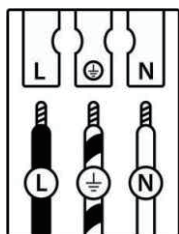

	(DE)	(GB)	(FR)	(NL)	(PL)	(NO)	(DK)
<b>L</b>	Stromführender Leiter	Live conductor	Conducteur	Spanningvoerende draad	Przewód prądowy	Strømførende leder	Strømførende leder
	Schutzleiter	Earth conductor	Conducteur de protection (terre)	Aardkabel	Przewód uziemiający	Jordledningen	Jordledningen
<b>N</b>	Neutralleiter	Neutral conductor	Conducteur neutre	Nulleider	Przewód zerowy	Nøytralleider	Neutralleider

	(SE)	(FI)	(IT)	(ES)	(CZ)	(PT)	(GR)
<b>L</b>	Strömförande ledare	Virtajohdin	Conduttore sotto tensione	Conductor de corriente	Vodič pod napětím	Condutor vivo	Ρευματοφόρος αγωγός
	Skyddsledare	Suojajohdin	Conduttore di terra	Conductor de protección	Ochranný vodič	Condutor de terra	Αγωγός γείωσης
<b>N</b>	Neutralledare	Nollajohdin	Conduttore neutro	Conductor neutro	Neutrální vodič	Condutor neutro	Ουδέτερος αγωγός

**FittinQ B.V.**

Smaragdweg 52, 5527 LB Hapert, The Netherlands  
www.qazqa.nl

QAZQA

