

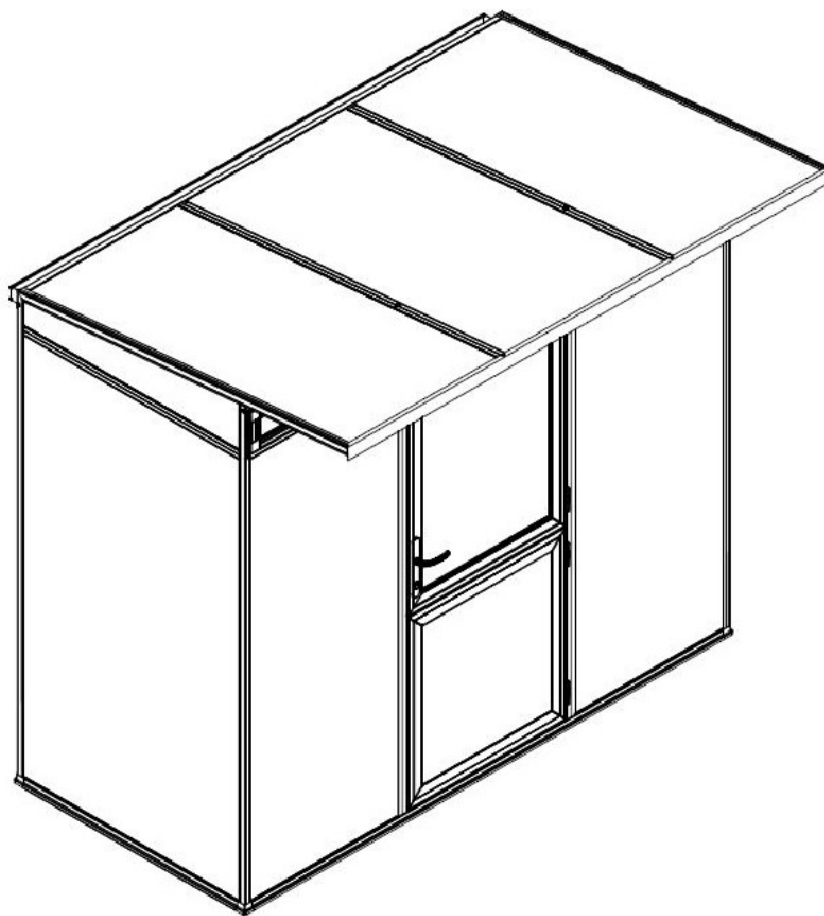

MONTAGEANLEITUNG
INSTALLATION INSTRUCTIONS
INSTRUCTIONS DE MONTAGE
MONTAGE-INSTRUCTIE

GEWÄCHSHAUS / GREENHOUSE / SERRE LINEA I



BITTE VOR DEM AUFBAU LESEN

PLEASE READ BEFORE SETTING UP
S'IL VOUS PLAÎT LIRE AVANT DE MONTER
LEES DIT VOORDAT U HET INSTELT

Technische Änderungen vorbehalten



DEUTSCH

Liebe Garten- und Pflanzenfreunde,
erst einmal möchten wir Sie zum Kauf eines Qualitäts-Produkts "Made in Germany" aus unserem Angebot beglückwünschen und Ihnen für Ihr Vertrauen in unsere Arbeit danken.

Montage

Die Montage des Gewächshauses ist einfach und kann größtenteils von einer Person durchgeführt werden. Bei bestimmten Schritten ist jedoch eine zweite Person zwingend erforderlich.

Der Zeitaufwand hängt von vielen Faktoren ab. Wichtig ist hierbei, dass das Endergebnis stimmt und Sie zufrieden sind.

Sollten Sie die Montage nicht selbst durchführen wollen, finden Sie im Servicebereich unter

www.kgt-gmbh.de

einige Montagepartner, die die Montage gern für Sie ausführen.
Sie können bei Rückfragen auch gern unseren Kundenservice telefonisch kontaktieren:

Tel. (0049) 0 49 56/40 75-0.

Sie erreichen uns von Mo. bis Fr. von 07:00 - 17:00 Uhr.

Lieferumfang

Bitte arbeiten Sie die einzelnen Arbeitsschritte in der Reihenfolge der Montageanleitung ab. Bitte nicht alle Kartons gleichzeitig öffnen! Lassen Sie sich nicht durch die Vielzahl der Einzelteile verwirren.

Bevor Sie mit der Montage beginnen, prüfen Sie anhand der Stücklisten, ob alle Teile vorhanden und unverstört sind. Jeder Karton durchläuft eine strenge Qualitätskontrolle, bevor er verschlossen wird. Durch diese und andere Maßnahmen können wir Fehlerteile nahezu ausschließen. Sollte dennoch etwas nicht in Ordnung sein, geben Sie uns eine Information unter der

Tel. (0049) 0 49 56/40 75-0 bzw. per e-mail: info@kgt-gmbh.de

Wir kümmern uns dann kurzfristig um Ersatz.

Beachten Sie bitte, dass bei einer pressblanken Konstruktion leichte Kratzer bzw. Schieferspur an den Aluminiumprofilen herstellungsbedingt nicht vermeidbar sind und keinen Reklamationsgrund darstellen. Bei Fragen hierzu können Sie uns gern kontaktieren.

Sicherheitshinweise

Das Gewächshaus sollte möglichst an einer windgeschützten Stelle und nicht bei stürmischem Wetter aufgestellt werden. Es ist gefährlich, ein teilweise montiertes Gewächshaus ungeschützt der Witterung auszusetzen.

Bei vorschriftsmäßiger Montage widersteht dieses Gewächshaus auch heftigem Wind. Bei Unwettern müssen Sie die Fenster und Türen schließen und ggf. zusätzlich sichern. Das Gewächshaus ist von Schneelasten höher als 10 cm zu befreien. Keine offene Feuerstelle im Gewächshaus errichten. Arbeiten Sie mit sicheren, handwerksgerechten Werkzeugen. Achten Sie bei der Montage auf einen sicheren Stand der Leiter (Unfallgefahr!). Grundsätzlich nur mit Handschuhen arbeiten (Verletzungsgefahr, Schnittgefahr!). Das Gewächshaus ist zur ortsfesten Nutzung vorgesehen und muss daher auf einem geeigneten Untergrund verankert werden.

⚠️ Warnung!!! ⚠️

Lebens-/Unfallgefahr für Kleinkinder und Kinder

Bitte lassen Sie Ihre Kinder niemals unbeaufsichtigt mit dem Verpackungsmaterial spielen.
Es besteht Erstickungsgefahr. Während der Montage des Produktes sollten Sie Ihre Kinder vom Aufbauort fernhalten, da im Lieferumfang Kleinteile mit Erstickungsgefahr und scharfkantige Profile enthalten sind.

Das Produkt ist kein Kletter- oder Spielgerät, daher lassen Sie Ihre Kinder nicht unbeaufsichtigt. Stellen Sie sicher, dass sich Personen, besonders Kinder, nicht auf das Produkt stellen/hochziehen oder hineinklettern, da Kipp-/Erstickungsgefahr besteht. Es ist sicherzustellen, dass das Produkt auf einem festen und ebenen Untergrund steht. Verletzungen und/oder Sachschäden können die Folge bei Nichtbeachtung der o. g. Punkte sein.

Für den Aufbau benötigen Sie folgende Werkzeuge:

- 1 Stück Kreuzschlitzschraubendreher PH 2
- 1 Stück Maul- bzw. Gabelschlüssel 10 mm
- 1 Stück Schlitzschraubendreher
- 1 Stück Innensechskantschlüssel 3 mm (im Zubehörbeutel Dachfenster)
- 1 Stück Feile, um evtl. Grat an den Profilen zu entfernen
- 1 Stück Stehleiter
- 1 Stück Wasserwaage
- 1 Stück Gummihammer
- 1 Stück Maßband
- 1 Stück Schere/Messer

ENGLISH

Dear friends of gardening and planting

Advice on safety

First of all we want to congratulate you for the purchase of our quality product "made in germany". Our team thanks you for trusting us.

Montage

The setup of the house is simple and can be done by one person most of the time. To fulfill certain steps, two people are required.

The duration of building depends on various factors. In the end, it is very important, that you are happy with the result.

If you do not want to assemble the greenhouse by yourself, you will find mechanics in our service section:

www.kgt-gmbh.de

who will help you build it or do it all by themselves.

In the case of questions, you may contact our customer service by dialing:

Tel. (0049) 0 49 56/40 75-0.

You may reach us from monday to friday, 07:00 - 17:00 o'clock.

Scope of supply

Please build the greenhouse according to the steps in the manual. Do not open all the boxes simultaneously. Do not be confused by the variety of parts. By following the instructions you will understand.

Please check the parts by using the parts-list. Be sure that there are all the parts listed. Also check for errors and damages. The boxes are being controlled before they get sealed. By doing this, we can almost certainly rule out missing parts. Should there be a missing piece or damages, you can always contact us using:

tel. (0049) 0 49 56/40 75-0 or e-mail: info@kgt-gmbh.de

We shall deliver replacement as soon as possible.

Please be aware, that there may be scratches or marks on aluminium coloured greenhouses due to production processes. If you may have any questions on that, you can always contact us.

You should build the greenhouse in an area, where it is protected by wind and it should not be assembled during stormy weather. It is dangerous to subject a partly assembled house to weathering. If the house is build in accordance to the instruction, it can resist even strong winds. You need to safeguard the doors and windows during violent storms. The manufacturer will not take responsibility for damages due to higher forces. If there is snow higher than 10cm on the roof, you need to remove it. Do not start a fire (fireplace) in the house! Assemble the house only using safe tools. While using the ladder, be sure it stands safely on the ground. Do use gloves during the montage (risk of injury, cut accidents!). The house is supposed to be build in one place and not to be replaced afterwards. Make sure it anchored according to the regulations.

⚠️ Warning!!! ⚠️

Risk of injury/death for infants and children

Please do not let your children play with the packaging because of the risk of choking. During the setup of the house, make sure your children stay within a safe distance, due to small pieces and sharp edges. The product is no climbing frame, nor a playground, so make sure your children are supervised. Do not stand on the house or pull yourself up, because it could collapse or fall. You need to make sure, that the product stands on solid ground. By disregarding the advice from above, there might be injuries or material damages.

For the construction you will need the following tools:

- 1 x cross-slotted screwdrivers PH 2
- 1 x fork wrench 10 mm
- 1 x slotted screwdrivers
- 1 x allen key 3 mm (in the accessory bag for roof window)
- 1 x file
- 1 x ladder
- 1 x spirit level
- 1 x mallet
- 1 x measuring tape
- 1 x scissors / knife
- 1 x drill

FRANCAIS

Chers amis du jardin et des plantes,

Tout d'abord, nous tenons à vous féliciter pour l'achat d'un produit de qualité "Made in Germany" parmi notre sélection et à vous remercier pour votre confiance en notre travail.

Assemblage

L'assemblage du carré potager surélevé en aluminium est simple et peut être effectué par une personne. La durée dépend de nombreux facteurs et peut être estimée dans une fourchette d'une heure à trois heures environ. Il est important que le résultat final soit satisfaisant et que vous soyez content.

Si vous ne souhaitez pas réaliser le montage vous-même, vous trouverez dans la rubrique service

www.kgt-gmbh.de

quelques partenaires d'assemblage qui seront ravis d'effectuer le montage pour vous.
En cas de questions, vous pouvez également contacter notre service client par téléphone :

Tel. (0049) 0 49 56/40 75-0.

Vous pouvez nous joindre du lundi au vendredi de 07h00 à 17h00.

Contenu de la livraison

Veillez suivre les étapes de montage dans l'ordre indiqué dans le mode d'assemblage. N'ouvrez pas tous les cartons en même temps ! Ne vous laissez pas perturber par le grand nombre de pièces détachées.

avant de commencer le montage, vérifiez à l'aide des listes de pièces si tous les éléments sont présents et intacts. Chaque carton fait l'objet d'un contrôle qualité rigoureux avant d'être scellé. Grâce à ces mesures et d'autres encore, nous pouvons pratiquement exclure les pièces manquantes. Si toutefois quelque chose ne va pas, veuillez nous en informer au numéro suivant:

Tel. (0049) 0 49 56/40 75-0 bzw. per e-mail: info@kgt-gmbh.de

Nous nous occupons ensuite rapidement du remplacement.

Veillez noter que dans le cas d'une construction brute de presse, de légères rayures ou traces de meulage sur les profils en aluminium sont inévitables en raison du processus de fabrication, et ne constituent pas un motif de réclamation. Si vous avez des questions à ce sujet, n'hésitez pas à nous contacter.

Consignes de sécurité

L'aluminium-Hochbeet devrait être placé de préférence dans un endroit à l'abri du vent et non exposé à des conditions météorologiques venteuses. Il est dangereux de laisser un aluminium-Hochbeet partiellement assemblé exposé aux intempéries. En cas de montage conforme aux consignes, cet aluminium-Hochbeet résistera également aux vents violents. Le fabricant décline toute responsabilité pour les dommages causés par la force majeure. Ne pas construire de foyer ouvert dans l'aluminium-Hochbeet. Utilisez des outils sûrs et adaptés à l'artisanat. Assurez-vous d'avoir une position stable sur l'échelle lors du montage (risque d'accident!). Travailler toujours avec des gants (risque de blessure, risque de coupure!).

⚠️ Avertissement!!! ⚠️ Danger de mort / d'accident pour les tout-petits et les enfants

Veillez ne jamais laisser vos enfants jouer sans surveillance avec le matériel d'emballage. Risque d'étouffement. Pendant le montage du produit, éloignez vos enfants du lieu de montage, car des petites pièces présentant un risque d'étouffement et des profils tranchants sont inclus dans le contenu de la livraison. Le produit n'est pas conçu pour l'escalade ou le jeu, veillez donc à ne pas laisser vos enfants sans surveillance. Assurez-vous que les personnes, en particulier les enfants, ne montent pas sur le produit ni ne l'utilisent comme support, car il y a un risque de basculement. Assurez-vous que le produit repose sur une surface solide et plane. Le non-respect des points mentionnés ci-dessus peut entraîner des blessures et/ou des dommages matériels.

Pour la construction, vous aurez besoin des outils suivants:

- 1 x Tournevis cruciforme PH 2
- 1 x Clé à mâchoire ou à fourche 10 mm
- 1 x Tournevis à fente
- 1 x Clé hexagonale intérieure 3 mm (dans le sac d'accessoires de fenêtre de toit)
- 1 x Fichier pour ajouter éventuellement des bords sur les profils supprimer
- 1 x Échelle
- 1 x Balance à eau
- 1 x Marteau en caoutchouc
- 1 x Ruban à mesurer
- 1 x Ciseaux/couteaux

NEDERLANDS

Beste tuin- en plantenvrienden,

Allereerst willen wij u feliciteren met de aankoop van een kwaliteitsproduct "Made in Germany" uit ons aanbod en u bedanken voor uw vertrouwen in ons werk.

Vergadering

De montage van de technische ruimte is eenvoudig en kan meestal door twee personen worden gedaan.

De benodigde tijd is afhankelijk van vele factoren en kan worden geschat op een tijdsduur van één dag tot drie dagen. Het is belangrijk dat het eindresultaat klopt en dat je tevreden bent.

Als u de installatie niet zelf wilt uitvoeren, vindt u deze in het servic gedeelte onder

www.kgt-gmbh.de

enkele installatiepartners die de installatie graag voor u uitvoeren. Als u vragen heeft, neem dan gerust telefonisch contact op met onze klantenservice:

Tel. (0049) 0 49 56/40 75-0.

U kunt ons bereiken vanaf Mo. tot dat Fr. vanaf 07:00 - 17:00 klok.

Omvang van de levering

Doorloop de afzonderlijke werkstappen in de volgorde van de montage-instructies. Gelieve niet alle doos tegelijk te openen! Laat u niet in de war brengen door de verscheidenheid aan afzonderlijke onderdelen.

Controleer voordat u begint met monteren de stuklijsten om er zeker van te zijn dat alle onderdelen aanwezig en intact zijn. Elke doos ondergaat een strenge kwaliteitscontrole voordat deze wordt verzegeld. Door deze en andere maatregelen kunnen we onbrekende onderdelen vrijwel elimineren. Als er echter iets mis is, laat het ons dan weten op het volgende adres:

Tel. (0049) 0 49 56/40 75-0 bzw. per e-mail: info@kgt-gmbh.de

Wij zorgen dan op korte termijn voor vervangingen.

Houd er rekening mee dat bij een gepolijste constructie lichte krassen of schuursporen op de aluminium profielen door het fabricageproces niet kunnen worden vermeden en geen reden tot reclamatie vormen. Als u vragen heeft, aarzel dan niet om contact met ons op te nemen.

Veiligheid

Indien mogelijk moet het object op een plaats worden geplaatst die beschermd is tegen de wind en niet bij stormachtig weer. Het is gevaarlijk om een gedeeltelijk gemonteerd model zonder bescherming bloot te stellen aan weersinvloeden. Wanneer dit object volgens de voorschriften wordt geïnstalleerd, is het ook bestand tegen harde wind. Bij slecht weer moet u de ramen en deuren sluiten en indien nodig extra beveiligen. De fabrikant aanvaardt geen aansprakelijkheid voor schade veroorzaakt door overmacht. Het ultrating compartiment moet worden vrijgemaakt van sneeuwbelasting hoger dan 10 cm. Bouw geen open haard in de technische ruimte. Werk met veilig gereedschap dat geschikt is voor het ambacht. Zorg er bij de montage voor dat de ladder stevig is gepositioneerd (gevaar voor ongevallen!). Werk in principe alleen met handschoenen (gevaar voor letsel, risico op snijwonden!). De technische ruimte is bedoeld voor stationair gebruik en moet daarom op een geschikte ondergrond worden verankerd.

⚠️ Waarschuwing!!! ⚠️

Levensgevaar/ongeval voor zuigelingen en kinderen

Laat uw kinderen nooit zonder toezicht met het verpakkingsmateriaal spelen. Er bestaat verstikkingsgevaar. Tijdens de montage van het product dient u uw kinderen uit de buurt van de montageplaats te houden, aangezien de leveringsomvang kleine onderdelen met verstikkingsgevaar en scherpe profielen omvat. Het product is geen klim- of speeltoestel, dus laat uw kinderen niet zonder toezicht achter. Zorg ervoor dat mensen, vooral kinderen, niet bovenop het product gaan staan, ze niet omhoog trekken of erin klimmen, aangezien er een risico op kantelen/stikken bestaat. Er moet voor worden gezorgd dat het product op een stevige en vlakke ondergrond wordt geplaatst. Letsel en/of materiële schade kan leiden tot het niet naleven van de bovengenoemde punten.

Je hebt de volgende tools nodig om het in te stellen:

- 1 Stück Kruiskopschroevendraaier PH2
- 1 Stück Steeksleutel 10 mm
- 1 Stück Platte schroevendraaier
- 1 Stück Inbussleutel 3 mm
- 1 Stück Vijl om eventuele bramen op de profielen te verwijderen
- 1 Stück Trapladder
- 1 Stück Niveau
- 1 Stück Mallet
- 1 Stück Scharen/messen
- 1 Stück Schere/Messer

DEUTSCH

Identifizieren der Profile

1. Querschnitt beachten
2. Abmessungen nehmen

Hinweise zur Verglasung

Auf keinen Fall gleich nach dem Auspacken die Folien abziehen, damit die Platten nicht verkratzen, etc.

Die ISO-Hohlkammerplatten sprich Verglasung wird immer mit der Seite mit dem UV-Schutz außen eingebaut. Die Platten haben auf der Schutzfolie einen entsprechenden Hinweis bzw. eine farbige Folie.

Die Schutzfolien sollten Sie zunächst immer nur im Randbereich lösen und erst nach der fertigen Montage komplett entfernen. Setzen Sie die ISO-Hohlkammerplatten mit der Folie auf keinen Fall längere Zeit der Sonneneinstrahlung aus. Die Folie könnte unter Umständen auf den Platten einbrennen und nur noch schwer lösbar sein.

Bestimmungsgemäße Verwendung

Das von Ihnen erworbene Gewächshaus ist für die nicht gewerbliche Aufzucht von Pflanzen konstruiert und sollte auch ausschließlich dafür genutzt werden. Nicht zur Lagerung ätzender oder brennbarer Chemikalien oder Produkte empfohlen. Bei anderweitiger Nutzung ist jegliche Haftung ausgeschlossen.

Dichtungen

Die meisten Keildichtungen werden als Doppelstrang geliefert. Sie müssen diesen Strang deshalb in der Mitte auseinanderziehen, um zwei einzelne Dichtungen zu erhalten.

Da die Dichtungen, je nach Temperatur (im Sommer dehnt sie sich aus; im Winter zieht sie sich zusammen) arbeiten, beim Zuschneiden eine Zugabe lt. Zusatzblatt berücksichtigen.

Beispiel:
Türprofillänge x 5% Zugabe = X
748 mm x 1,05 = 785 mm

Wichtig ist, dass die Dichtungen "gestaucht" eingearbeitet werden. Durch Scannen des QR-Codes können Sie Details zum Einsetzen der Dichtungen einsehen.



Alternativ finden Sie den Montagehinweis unter folgendem Link:

<https://www.kgt-gmbh.de/service/download/oeffentlich/>

Standort

Wählen Sie, soweit möglich, einen sonnigen Platz für Ihr Gewächshaus. Meiden Sie den Schatten von Gebäuden und Bäumen. Für Gemüse, wie Tomaten, Gurken und Melonen, stellen Sie Ihr Gewächshaus möglichst in Nord-Süd-Richtung auf. Blumen und Topfpflanzen bevorzugen die Ost-West-Richtung.

Wasser und Kondensat

Wir weisen darauf hin, dass das Gewächshaus nicht mit einem Wintergarten zu vergleichen ist. Je nach Wetterlage bzw. Niederschlägen können Undichtigkeiten auftreten sowie Kondensatbildung an den Hausinnenseiten und im Inneren der Hohlkammerplatten. Dieser Effekt tritt auf, da die ISO-Hohlkammerplatten nicht "wasserdampf-diffusionsfest" sind, d. h. Feuchtigkeit tritt in Form von Wasserdampf in die Platte ein und führt u. a. zu einer "beschlagenen" Optik. Dies ist ein rein optischer Effekt und lässt sich bei korrekter Ausführung der Verglasung nicht vermeiden. Die Platten können dadurch keinen Schaden nehmen, auch nicht bei Frost.

Sich evtl. ansammelndes Wasser in den Profilen und Hohlkammerplatten wird über die Kunststoff-Eckverbinder im Bodenprofil abgeleitet. Es muss gewährleistet sein, dass das Wasser sowohl nach innen als auch nach außen ungehindert abfließen kann.

Pflege - Instandhaltung

Das Gewächshaus nur mit viel Wasser, z. B. weicher, nicht kratzender Autowaschbürste abwaschen. Die Verwendung eines Hochdruckreinigers wird nicht empfohlen. Bei stärkerer Verschmutzung können Sie zusätzlich eine milde Seifenlauge (keine Bleiche, Ammoniak oder alkalische Reiniger!) zur Unterstützung der Reinigung verwenden. Achten Sie in solchen Fällen auf die Verwendungshinweise des verwendeten Mittels. Wir übernehmen keine Haftung für Schäden, die im Rahmen unsachgemäßer Anwendung falscher Reinigungsmittel auftreten. Schrauben, Muttern, Bolzen usw. regelmäßig prüfen und gegebenenfalls nachziehen/schmieren.

Versicherung

Wir weisen Sie darauf hin, dass nicht alle Versicherungen automatisch Gewächshäuser abdecken. Bitte erfragen Sie dies bei Ihrer Versicherung.

ENGLISH

Identification of the profiles

1. Consider cross-section
2. Take dimensions

Information regarding glazing

Do not tare of the foil right after unpacking, so the plates do not get scratched or damaged.

The ISO-hollow-chamber-plates do always have two sides. One has UV-protection, which is stated on the plates. This is the outside.

Only remove the foil on the edges of the plate before setting the house up. After the assembly is completed, remove the rest. Protect the plates from solar radiation. The reason: The foil could burn into the plates, which would leave marks. Also, it could be very hard to remove.

Use as intended

The greenhouse you just purchased was constructed for gardening and planting and should be used as such. It is not suited to be used as storage for chemicals or flammable substances. We do not take liability for improper use.

Seals

The most of the wedge seals are delivered in double strands. You have to pull the strands apart to get two separated seals. Due to weaving temperatures the seal subjects to length extension. As a result you need to cut the seal like it is shown in the following example:

door profile x 5% addition = X
748 mm x 1,05 = 785 mm

It is important, that the seals are being compressed, when set in. By scanning the QR-Code you will get further information regarding this subject:



Alternatively you can follow the link below for more setup advice:

<https://www.kgt-gmbh.de/service/download/oeffentlich/>

Location

Choose a sunny location for your greenhouse. Avoid the shadows thrown by buildings or trees. For vegetables, such as tomatoes, cucumbers or melons, align your house in a north-south-direction. Flowers and potplants prefer a east-west-directed house.

Water and condensate

In case of heavy rains or storm, leaks may occur. There might also be condensate on the inside of the house or the hollow-chamber-plates. This happens, because the plates are not diffusion proof, which means, that humidity enters the plate as vapour. This leads to fogged optics. This is an optical effect, which can not be avoided, even when the plates are set up correctly. The plates do not get damaged by this effect, neither when it is freezing. The right choice of location and regular ventilation can reduce said effect.

The water, that might have appeared inside of the plates is able to drain through the plastic corner connectors. It has to be guaranteed, that water can drain from the in- to the outside and the other way round.

Care - Maintenance

Only use soft brushes and lots of water to clean the house. It is not recommended to use high-pressure cleaners. In case of bigger pollution use mild soaps instead of chemicals, such as bleach, ammoniak or alkaline cleaners.

Follow the instructions given by the producer of such cleaners. We do not assume liability on damages caused by cleaners, which were inappropriate to use on aluminium or the colours.

Screws, Nuts, bolts etc. have to be checked in time and need to be tightened and lubricated regularly.

Insurance

We want to make you aware of the fact, that greenhouses are not necessarily included in insurance policies. You should have let this be checked by your insurance agency.

FRANCAIS

Identification des profils

1. Tenir compte de la section
2. Prendre les dimensions

Instructions concernant le vitrage

En aucun cas immédiatement après le déballage enlever les feuilles pour que les plaques ne les égratignent, etc.

Les plaques à chambre creuse ISO dire vitrage est toujours installé avec le côté avec la protection UV à l'extérieur. Les plaques portent une mention appropriée ou une feuille de couleur sur le film protecteur.

Vous devez d'abord toujours détacher les films de protection uniquement dans la zone périphérique et ne les retirer complètement qu'une fois le montage terminé. N'exposez en aucun cas les plaques à chambre creuse ISO avec le film pendant une période prolongée de temps au rayonnement solaire. Le film pourrait graver sur les plaques et être difficile à dissoudre.

Utilisation conforme

Le produit est destiné à une utilisation en extérieur et ne doit pas être utilisé à des fins commerciales. En cas d'utilisation incorrecte ou inappropriée, comme par exemple une surcharge due à des objets suspendus ou une modification du produit, cela peut entraîner des dommages au produit. Pour le remplissage correct du carré potager surélevé, veuillez vous référer au schéma à la page 25.

Joints d'étanchéité

La plupart des joints en coin sont livrés sous forme de double corde. Vous devez donc séparer cette corde en deux au milieu pour obtenir deux joints individuels. Comme les joints travaillent en fonction de la température (ils se dilatent en été ; ils se rétractent en hiver), veillez à prévoir une marge de coupe conformément à la feuille supplémentaire.

Exemple:

Longueur du profil de porte x 5% d'ajout = X
748 mm x 1,05 = 785 mm

"Il est important que les joints soient "comprimés." En scannant le code QR, vous pouvez consulter les détails concernant la mise en place des joints.



En alternative, vous trouverez les instructions de montage à l'adresse suivante :

<https://www.kgt-gmbh.de/service/download/oeffentlich/>

Emplacement

Choisissez, dans la mesure du possible, un emplacement ensoleillé pour votre carré potager surélevé en aluminium. Évitez l'ombre des bâtiments et des arbres. Pour les légumes tels que les tomates, les concombres et les melons, installez votre carré potager surélevé en aluminium de préférence dans la direction nord-sud. Les fleurs et les plantes en pot préfèrent la direction est ouest.

Eau et condensats

Nous attirons votre attention sur le fait que la serre n'est pas comparable à un jardin d'hiver. En fonction des conditions météorologiques ou des précipitations, des fuites et de la condensation peuvent se produire à l'intérieur de la maison et à l'intérieur des plaques à chambre creuse. Cet effet se produit parce que les plaques à chambre creuse ISO ne sont pas "résistantes à la diffusion de la vapeur d'eau", c'est-à-dire que l'humidité pénètre dans la plaque sous forme de vapeur d'eau et conduit, entre autres, à une optique "cachée". Il s'agit d'un effet purement optique qui ne peut être évité si le vitrage est correctement exécuté. Les plaques ne peuvent pas être endommagées, même en cas de gel.

L'eau éventuellement accumulée dans les profilés et les plaques creuses est évacuée par les connecteurs d'angle en plastique dans le profil de sol. L'écoulement de l'eau vers l'intérieur et vers l'extérieur doit être assuré.

Entretien - Maintenance

Laver la serre seulement avec beaucoup d'eau, par exemple une brosse de lavage de voiture douce et non rayeuse. L'utilisation d'un nettoyeur haute pression n'est pas recommandée. En cas de saletés plus importantes, vous pouvez également utiliser une solution savonneuse douce (pas d'eau de Javel, d'ammoniaque ou de nettoyants alcalins !) pour faciliter le nettoyage.

Dans de tels cas, respectez les instructions d'utilisation du produit utilisé. Nous déclinons toute responsabilité pour les dommages résultant de l'utilisation incorrecte de produits de nettoyage incorrects.

Vérifier régulièrement les vis, écrous, boulons, etc., et, le cas échéant, les remplacer/lubrifier.

Assurance

Nous attirons votre attention sur le fait que toutes les assurances ne couvrent pas automatiquement les carrés potagers surélevés. Veuillez vous renseigner auprès de votre assurance.

Clause de non-responsabilité

En cas d'utilisation non conforme et de non-respect des consignes de sécurité, nous déclinons toute responsabilité en cas de dommages consécutifs aux personnes ou aux éléments.

NETERLANDS

Identificatie van de profielen

1. Let op de doorsnede
2. Metingen uitvoeren

Opmerkingen over beglazing

De ISO-dubbelwandige panelen, d. w. z. beglazing, worden altijd met de kant met UV-bescherming aan de buitenkant geïnstalleerd. De platen zijn voorzien van een bijbehorend briefje op de beschermfolie of een gekleurde folie.

De folies mogen in geen geval onmiddellijk na het uitpakken worden verwijderd, zodat de platen geen krassen maken, hat!

In eerste instantie moet u de beschermfolies alleen aan de randen losmaken en pas volledig verwijderen nadat de installatie is voltooid. Plaats de beglazing niet op een Vermijd langdurige blootstelling aan zonlicht. Onder bepaalde omstandigheden kan de folie op de beglazing branden en moeilijk op te lossen zijn.

Beoogd gebruik

De kas die u hebt gekocht, is ontworpen voor de niet-commerciële teelt van planten en mag ook uitsluitend voor dit doel worden gebruikt. Niet aanbevolen voor het opslaan van bijtende of ontvlambare chemicaliën of producten. Bij ander gebruik is iedere aansprakelijkheid uitgesloten

Zeehonden

De meeste wigafdichtingen worden als dubbele streng geleverd. Je moet deze streng dus in het midden uit elkaar trekken om twee individuele zegels te krijgen.

Omdat de afdichtingen werken volgens de temperatuur (in de zomer zet het uit; in de winter trek het samen), moet bij het snijden rekening worden gehouden met een toevoeging.

Voorbeeld:
Lengte deurprofiel x 5% Toegift = X
748 mm x 1,05 = 785 mm

Het is belangrijk dat de afdichtingen op een "gecomprimeerde" manier worden verwerkt. Door de QR-code te scannen, kunt u details zien over het plaatsen van de zegels.



U kunt de installatie-instructies ook vinden via de volgende link:

<https://www.kgt-gmbh.de/service/download/oeffentlich/>

Plaats

Kies indien mogelijk een zonnige plek voor uw kas. Vermijd de schaduw van gebouwen en bomen. Voor groenten, zoals tomaten, komkommers en meloenen, plaats je je kas indien mogelijk in noord-zuid richting. Bloemen en potplanten geven de voorkeur aan de oost-west richting.

Water en condensaat

Afnankelijk van de weersomstandigheden of neerslag kunnen lekkages optreden, evenals condensvorming aan de binnenkant van het huis en in de dubbelwandige panelen. Dit effect treedt op omdat de ISO-dubbelwandige panelen niet "waterdampdiffusiebestendig" zijn, d. w. z. vocht komt in de vorm van waterdamp de plaat binnen en leidt onder andere tot een "beslagen" uiterlijk. Dit is een puur visueel effect en kan niet worden vermeden als de beglazing correct is uitgevoerd. De platen kunnen hierdoor niet beschadigd raken, zelfs niet bij vorst. De keuze van de locatie en voldoende ventilatie kunnen dit effect verminderen.

Eventueel opgehoopt water in de profielen en dubbelwandige panelen wordt afgevoerd via de kunststof hoekverbinders in het vloerprofiel. Er moet voor worden gezorgd dat het water ongehinderd zowel naar binnen als naar buiten kan weglopen.

Verzorging - Onderhoud

Was het apparaatcompartiment alleen met veel water, bijv. een zachte, niet-krassende autowasborstel. Het gebruik van een hogedrukreiniger wordt niet aanbevolen. In geval van zwaardere vervuiling kunt u ook een mild sopje gebruiken (geen bleekmiddel, ammoniak of alkalische reinigingsmiddelen!) om te helpen bij het schoonmaken. Let in dergelijke gevallen op de gebruiksaanwijzing van de gebruikte remedie. Wij aanvaarden geen enkele aansprakelijkheid voor schade veroorzaakt door oneigenlijk gebruik van verkeerde reinigingsmiddelen. Controleer schroeven, moeren, bouten, enz. regelmatig en draai ze indien nodig vast/smeren.

Verzekering

Houd er rekening mee dat niet alle verzekeringen deze eigendommen automatisch dekken. Neem contact op met uw verzekeringsmaatschappij.

DEUTSCH

Versiegelung

Die waagerechten Übergänge von der Verglasung zum Profil sind mit neutral-vernetztem, transparentem Silikon zu versiegeln, damit möglichst wenig Wasser und damit auch wenig Schmutz in die Verglasungsaufnahmen gelangen kann. Vorteil: Das Gewächshaus sieht auf Dauer optisch besser aus. Die Neigung zur Algenbildung nimmt gerade in diesen Bereichen erheblich ab.

Dauerelastische Versiegelungsfugen sind Wartungsfugen und unterliegen daher nicht der Gewährleistung oder Garantie und müssen regelmäßig überprüft werden.

Achtung:

Zur Versiegelung nur "neutral vernetztes" Silikon einsetzen. Dies ist der gängigste Silikon-Dichtstoff. Er ist in jedem Baumarkt oder bei KGT für ca. 4 - 7 Euro pro 310 mm-Kartusche erhältlich. Eine Kartusche liegt dem Produkt bei.

Haftungsausschluss

Bei bestimmungswidriger Verwendung und bei Nichtbeachten der Sicherheitshinweise übernehmen wir keine Haftung für Schäden/Folgeschäden an Personen oder Elementen. Die Firma KGT - Kreative Gartentechnik GmbH übernimmt keine Haftung für die sich im Gewächshaus befindlichen Gegenstände. Es obliegt dem Endanwender den Inhalt regelmäßig zu überprüfen. Bitte beachten Sie, dass der Hersteller weder für die Folgen haftet, wenn das Gewächshaus nicht nach diesen Anweisungen aufgestellt wird, noch für Schäden aufgrund der Witterung oder höherer Gewalt.

Eine Bitte an Sie

Für unsere Werbemaßnahmen sind wir ständig auf der Suche nach neuem Bildmaterial.

Gern können Sie uns nach erfolgter Montage einige Aufnahmen Ihrer neuen Oase im Grünen zuschicken, idealerweise in digitaler Form. Richten Sie Ihre Nachricht einfach an:

info@kgt-gmbh.de

Wir bedanken uns vorab für Ihre Mühe und freuen uns auf Ihre Impressionen.

Symbolik



Dichtung auf Gehrung passend zuschneiden



Ansicht von innen



Ansicht von außen



Anzahl der zu wiederholenden Schritte



Ansicht um 180° gedreht



Ist im Lieferumfang des Bauteils enthalten!



Bauteil demontieren/entfernen



Bauteil eindrehen



Vereinfachte Darstellung



Hier Silikon benutzen!

(Verarbeitungshinweise seitens des Herstellers auf der Kartusche sind zu beachten!)

ENGLISH

Sealing

In principle, the house does not need to be sealed. But we strongly recommend to seal the transmissions between the profiles and the plates, so that no water or dirt might get in. The advantage is, that your house does look cleaner for a much longer time. Also it is way easier to clean! Only use neutral cross-linked silicone to do so.

Permanently elastic sealing joints are maintenance joints and are therefore not subjected to warranty. They need to be checked from time to time.

Attention:

For sealing, you do have to use neutral cross-linked silicone, because otherwise your hollow-chamber plates might crack out of tension.

There is one cartouche within the boxes.

Disclaimer

In case of damages, concerning elements, people or other, we do not assume liability due to unintended use of this product, nor disregarded safety notes. The company "KGT - Kreative Gartentechnik GmbH" does not assume liability for objects inside of the house or room. The end-user is in charge of checking the content inside of it. Please be aware of the fact, that the producer does not assume liability for damages resulting from wrong set up or higher forces.

A request to you

For advertising, we are always in search of new pictures, showing our products. If you want, you might send us a picture of your "green oasis", ideally digitally. Please send us a message:

info@kgt-gmbh.de

We thank you for your efforts and are looking forward to your homemade impressions!

Symbolism



Cut gasket to miter fitting



View from the inside



View from the outside



Number of repeating steps



Turn view



Is included in the delivery of the component!



Remove component!



Turn component



Simplified view



Use silicone!

(Processing instructions from the manufacturer on the cartridge must be observed!)

FRANCAIS

Scellage

Les passages horizontaux entre le vitrage et le profil doivent être scellés avec du silicone neutre et transparent, afin de réduire au minimum l'entrée d'eau et donc de saleté dans les vitrages.

Avantage: La serre a une meilleure apparence visuelle à long terme. C'est précisément dans ces zones que la propension à la formation d'algues diminue considérablement.

Les joints d'étanchéité élastiques durables sont des joints d'entretien et ne sont donc pas couverts par la garantie ou la garantie et doivent être vérifiés régulièrement.

Attention :

N'utiliser que du silicone "réticulant neutre" pour l'étanchéité. C'est le mastic silicone le plus commun. Elle est disponible dans tous les magasins de bricolage ou chez KGT pour environ 4 à 7 euros la cartouche de 310 mm. Une cartouche est fournie avec le produit.

Exclusion de responsabilité

En cas d'utilisation non conforme et de non-respect des consignes de sécurité, nous déclinons toute responsabilité pour les dommages consécutifs aux personnes ou aux éléments. La société KGT - Kreative Gartentechnik GmbH n'assume aucune responsabilité pour les objets se trouvant dans la serre. Il incombe à l'utilisateur d'en vérifier régulièrement le contenu. Veuillez noter que le fabricant n'est pas responsable des conséquences si la serre n'est pas installée conformément à ces instructions, ni des dommages dus aux intempéries ou à la force majeure.

Une demande de votre part

Pour nos campagnes publicitaires, nous sommes constamment à la recherche de nouveaux visuels.

Vous pouvez volontiers nous envoyer quelques photos de votre nouveau coin de paradis vert après avoir terminé le montage, de préférence sous forme numérique. Envoyez simplement votre message à :

info@kgt-gmbh.de

Hous vous remercions d'avance pour vos efforts et nous réjouissons de voir vos impressions.

Symbolique



Couper le joint d'étanchéité



Vue de l'intérieur



Vue de l'extérieur



Nombre d'étapes à répéter



Vue du dessous, pivotée à 180°



Est inclus dans la livraison du composant!



Démontage/retrait d'un composant



Serrer la vis / Visser le composant



Représentation simplifiée



Utilisez du silicone ici !

(Les instructions de manipulation indiquées par le fabricant sur la cartouche doivent être respectées!)

NEDERLANDS

Afdichting

In principe hoeft het koude frame niet te worden verzegeld. We raden echter aan om de overgangen van de beglazing naar het profiel af te dichten met neutraal vernetste, transparante siliconen, zodat er zo min mogelijk water en dus weinig vuil in de glasbakken kan komen. Voordeel: Het ontbijtbed ziet er op de lange termijn beter uit. Vooral in deze gebieden neemt de neiging tot algenvorming aanzienlijk af.

Blijvend elastische afdichtingsvoegen zijn onderhoudsvoegen en vallen daarom niet onder garantie of waarborg.

Aandacht:

Gebruik voor de afdichting alleen "neutrale crosslinking" siliconen, anders kunnen er spanningscheuren in de kunststof beglazing ontstaan. Dit is de meest voorkomende siliconenkit. Het is verkrijgbaar in elke bouwmarkt of bij KGT voor ongeveer 4 - 7 euro per 310 mm patroon. Bij het koude frame wordt een cartridge meegeleverd.

Disclaimer

Bij oneigenlijk gebruik en het niet in acht nemen van de veiligheidsinstructies aanvaardt u geen aansprakelijkheid voor schade/gevolgschade aan personen of elementen. Het bedrijf KGT - Kreative Gartentechnik GmbH aanvaardt geen aansprakelijkheid voor de zaken in het onroerend goed. Het is de verantwoordelijkheid van de eindgebruiker om de inhoud regelmatig te controleren. Houd er rekening mee dat de fabrikant niet aansprakelijk is voor de gevolgen als het model niet volgens deze instructies is ingesteld, noch voor schade als gevolg van weersomstandigheden of overmacht.

Een verzoek aan u

We zijn voortdurend op zoek naar nieuwe beelden voor onze reclameactiviteiten.

Na de installatie bent u van harte welkom om ons enkele foto's van uw nieuwe oase op het platteland te sturen, idealiter in digitale vorm. Stuur uw bericht naar:

info@kgt-gmbh.de

Wij danken u bij voorbaat voor uw inspanningen en kijken uit naar uw indrukken.

Symbolisme



Snijd de pakking om in de verstek te passen



Uitzicht van binnenuit



Uitzicht van buitenaf



Aantal te herhalen stappen



Weergave 180° gedraaid



Is bij de levering van het onderdeel inbegrepen!



Demonteren/verwijderen van het onderdeel



Draai het onderdeel totdat het kantelt!



Vereenvoudigde presentatie



Gebruik hier siliconen!

(Verwerkingsinstructies van de fabrikant op de Cartridges moeten in acht worden genomen!)

INHALTSVERZEICHNIS

list of contents / table des matières / inhoudsopgave

Linea I

Deckblatt / bract / cape / dekblad	1
Allgemeine Hinweise / general information / remarques générales / Algemene informatie	2 – 4
Symbolik / symbolism / symbolique / symboliek	4
Inhaltsverzeichnis / list of contents / table des matières / inhoudsopgave	5 – 6
Gründung des Gewächshauses (Fundamentrahmen) / Fundamental framework / Cadre général / Het Kader van de stichting	7
Gründung des Gewächshauses (Streifenfundament) / strip foundation / fond de bande / Strook fundering	8
Stückliste Fundamentrahmen / Parts list foundation frame / Liste des pièces cadres de fondation / Onderdelenlijst funderingsframe	9
Montage Fundamentrahmen / Assembly foundation frame / Montage des cadres de fondation / Installatie van funderingsframes	10 – 15
Stückliste Oberlicht / List of materials skylight / Liste des pièces Feu de tête / Onderdelenlijst dakraam	16 – 17
Montage Oberlicht / Mounting skylight / Montage du feu supérieur / Montage dakraam	18 – 27
Stückliste Tür oben / Parts list door top / Liste des pièces porte en haut / BOM Deur Top	28 – 29
Montage Tür oben / Mounting door top / Montage porte en haut / Montage van de deur aan de bovenkant	30 – 44
Stückliste Tür unten / Parts list door down / Liste des pièces porte en bas / BOM Deur Bodem	45 – 46
Montage Tür unten / Mounting door down / Montage porte en bas / Montagedeur aan de onderzijde	47 – 57
Stückliste Rückwandfenster / Parts list rear window / Liste des pièces Fenêtre du fond d'écran / Onderdelenlijst achterwandruit	58 – 59
Montage Rückwandfenster / Installation of rear wall windows / Montage des vitres arrière / Installatie van achterwandramen	60 – 70
Stückliste Rückwandgiebel / Parts list Rear wall gables / Liste des pièces des chevilles de paroi arrière / Onderdelenlijst achterwand gevel	71 – 72
Montage Rückwandgiebel / Installation of rear gable / Montage des chevilles de paroi arrière / Plaatsing van de achterwandgevel	73 – 82
Stückliste Türgiebel / Parts list door gable / Liste des pièces pignon de porte / Onderdelenlijst deurgevel	83 – 85
Montage Türgiebel / Installation of door gable / Montage des pignons de porte / Montage van de deurgevel	86 – 99
Stückliste Seitenelement / Parts list side element / Liste de pièces Élément latéral / Stuklijst zij-element	100 – 101

DEUTSCH

GRÜNDUNG A Fundamentrahmen zum Eingraben (Optional)

Dies ist die einfachste und sicherste Gründung eines Gewächshauses.

Achtung:

**Auf keinen Fall vorab montieren!
Montage erfolgt zusammen mit dem
Gewächshaus.**

Der Fundamentrahmen wird kraftschlüssig in das Bodenprofil des Gewächshauses eingehakt und in den Ecken mit einem Eckwinkel verschraubt.

Hinweis:

Das Fundamentrahmenprofil ist in der Länge kürzer als das Bodenprofil.

Aufstellen mit dem Fundamentrahmen

Einen kleinen Graben (Spatenstich, ca. 10 - 12 cm tief) in den Abmessungen des Fundamentrahmens ausheben. In den Ecken möglichst je einen Pflasterstein waagrecht zu den anderen einsetzen. Diese dienen dann der sicheren Auflage und verhindern ein evtl. Absacken des Gewächshauses. Das Gewächshaus mit dem Fundamentrahmen in diesen "Graben" stellen und mit Erde anfüllen.

Zweckmäßig ist auch das Anlegen von Gartenplatten oder einem Steinpflaster, damit das Gewächshaus (z. B. bei starkem Regen) nicht von Schmutzspritzern überzogen wird. Außerdem gestaltet sich so das Arbeiten rund um das Gewächshaus einfacher (Rasenmähen, etc.).

ENGLISH

FOUNDATION A foundation frame for digging (optional)

This is the easiest and safest way of foundation for your house.

Attention:

Do not assemble the frame in the beginning. You need to assemble it, while building the house!

The foundation frame is hooked into the groundprofile and screwed together in the corner using framing angles.

Note:

The foundation frame profiles are shorter than the groundprofiles of the house!

Set up with foundation frame

Dig a ditch, 10-12 cm deep, into the ground. In the edges, put a paving stone horizontally into the ditch, so the house can not subside. After that, you may put your house into the ditch and fill it up with soil.

You may now surface the soil with paving stones or terrace plates, so your house will not be soiled by mud, when it is raining heavily.

It also makes it easier to work around the house, for example when you are mowing the lawn.

FRANCAIS

ANCRAGE A Cadre de base pour l'enfouissement (facultatif)

C'est la création la plus simple et la plus sûre d'une serre.

Attention:

En aucun cas pré-assembler! Le montage se fait en même temps que la serre.

Le cadre de fondation est fermement accroché dans le profil de sol de la serre et vissé dans les coins avec un angle.

Note:

Le profil du cadre de fondation est plus court en longueur que le profil du sol.

Mise en place avec le cadre de base

Creuser une petite tranchée (piquée de spatule, environ 10-12 cm de profondeur) dans les dimensions du cadre de fondation. Placer un pavé dans les coins, si possible, horizontalement par rapport aux autres. Ceux-ci servent alors à la pose sûre et empêchent un éventuel effondrement de la serre. Placer la serre avec le cadre de fondation dans ces "fosses" et remplir avec la terre.

Il est également conseillé de poser des dalles de jardin ou un pavé en pierre afin que la serre ne soit pas recouverte par des éclaboussures de saleté (par exemple en cas de fortes pluies). En outre, cela facilite le travail autour de la serre (tondre le gazon, etc.)

NEDERLANDS

STICHTING A Funderingsframe voor begraven (Optioneel)

Dit is de eenvoudigste en veiligste manier om een kas op te zetten

Aandacht:

**Niet van tevoren monteren!
De montage wordt samen met de kas
uitgevoerd.**

Het funderingsframe is geforceerd in te passen. Het bodemprofiel van de kas wordt ingehaakt en in de hoeken geschroefd met een hoekbeugel.

Tip:

Het funderingsframeprofiel is in lengte korter dan het vierprofiel.

Opzetten met het funderingsframe

Graaf een kleine greppel (spade, ca. 10 - 12 cm diep) in de afmetingen van het funderingsframe. Plaats indien mogelijk een straatsteen in elke hoek horizontaal ten opzichte van de andere. Deze dienen dan als een veilige ondersteuning en voorkomen dat het gewas doorzakt.

Huis. Plaats de kas met het funderingsframe in deze "greppel" en vul deze met aarde.

Het is ook raadzaam om tuinplaten of een stenen bestrating te leggen, zodat de kas niet bedekt is met vuilspatten (bijvoorbeeld bij hevige regenval). Het maakt het ook gemakkelijker om rond de kas te werken (het gras maaien)



GRÜNDUNG B Streifenfundament

Sollten Sie keinen Fundamentrahmen gekauft haben, muss die sichere Gründung mittels Streifenfundament erfolgen.

Erstellen Sie dann bitte ein solches Fundament gemäß den in der Tabelle beigefügten Maßvorgaben.

Sie haben auch die Möglichkeit Ihr Gewächshaus auf Tiefbordsteinen z. B. 50 x 30 x 10 cm zu gründen.

Beachten Sie bitte, dass das Fundament gleichmäßig waagrecht hergestellt wird. Das Gewächshaus dann bitte mit den mitgelieferten Befestigungswinkeln (V15) sicher im Beton verankern.

Schrauben und Dübel gehören nicht zum Lieferumfang.

FOUNDATION B strip foundation

If you did not buy a foundation frame, you need to ground your house on a strip foundation.

Please make sure your foundation is done, like it says in the table below.

Also you have the possibility to do your foundation via kerbs.

Please make sure your foundation is done horizontally. After this you can fasten your house, using the angle of attachment (V15).

Screws and Plugs are not in the scope of supply!

ANCRAGE B Fond de bande

Si vous n'avez pas acheté de cadre de fondation, la fondation sûre doit être faite à l'aide d'une fondation en bandes.

Ensuite, s'il vous plaît construire une telle fondation conformément aux normes de mesure figurant dans le tableau ci-joint.

Vous avez également la possibilité de fonder votre serre sur des pierres peu profondes.

Veillez noter que la fondation est faite uniformément horizontalement. Ancrer la serre solidement dans le béton avec les angles de fixation et les chevilles de 8/10 mm (au moins 2 pièces par côté) fournis.

Les vis et chevilles ne sont pas inclus dans la livraison.

STICHTING B Strook fundering

Als u geen funderingsframe heeft gekocht, moet de veilige fundering worden uitgevoerd door middel van een strookfundering.

Maak dan zo'n fundering volgens de afmetingen die in de tabel zijn bijgevoegd.

U heeft ook de mogelijkheid om uw kas op lage stoepranden op te zetten, bijvoorbeeld 50 x 30 x 10 cm.

Houd er rekening mee dat de fundering gelijkmatig horizontaal is gemaakt. Veranker de kas dan stevig in het beton met behulp van de meegeleverde montagebeugels (V15).

Schroeven en pluggen zijn niet inbegrepen.

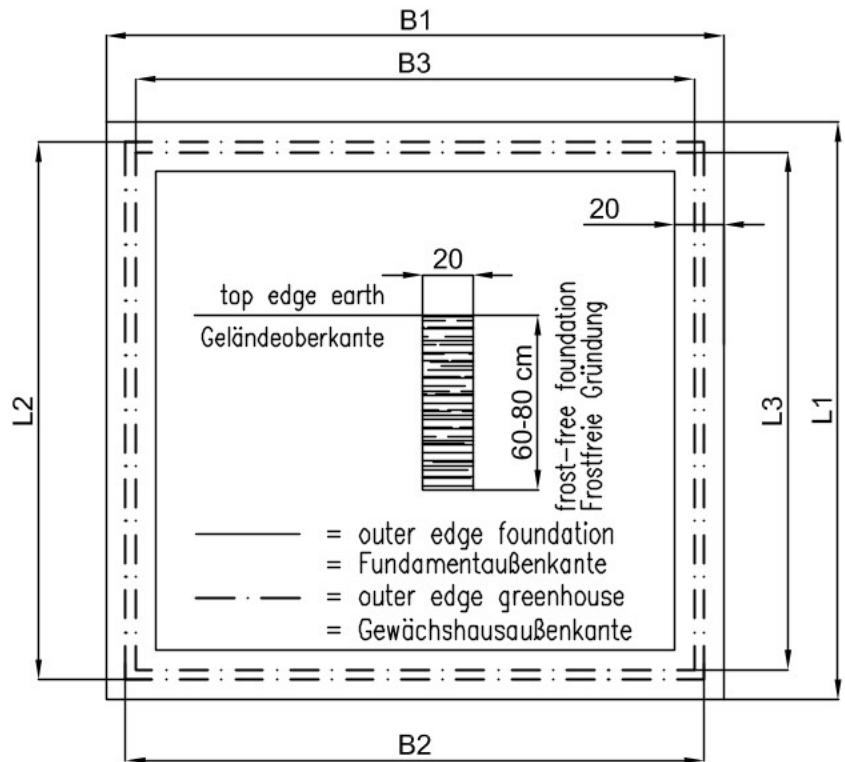







M6x12

V15

Modell	Fundament/ foundation		Gewächshaus/ greenhouse/ serre			
	B1	L1	B2	L2	B3	L3
Linea I	250	127	234	111	226	103
Alle Angaben in cm/ All data in cm/ Toutes les informations sont en cm.						

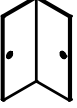
STÜCKLISTE

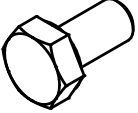
Fundamentrahmen Linea I

Pos.	Abbildung	Art.-Nr.	Bezeichnung	Anzahl	Bemerkung
1		P083-01-01-00-00-1	Fundamentrahmen (Giebel)	2	2188 mm
2		P083-13-01-00-00-1	Fundamentrahmen (Traufe)	2	964 mm
3		9999000078	Fundamentrahmen – Eckwinkel	4	
4		9999000267	Fundamentrahmen – Befestigungslasche	4	
5		9999000124	Sechskantschraube M6x12	16	DIN 933
6		9999000128	Sechskantmutter M6	16	DIN 934
7					
8					
9					
10					
11					
12					

I

VD

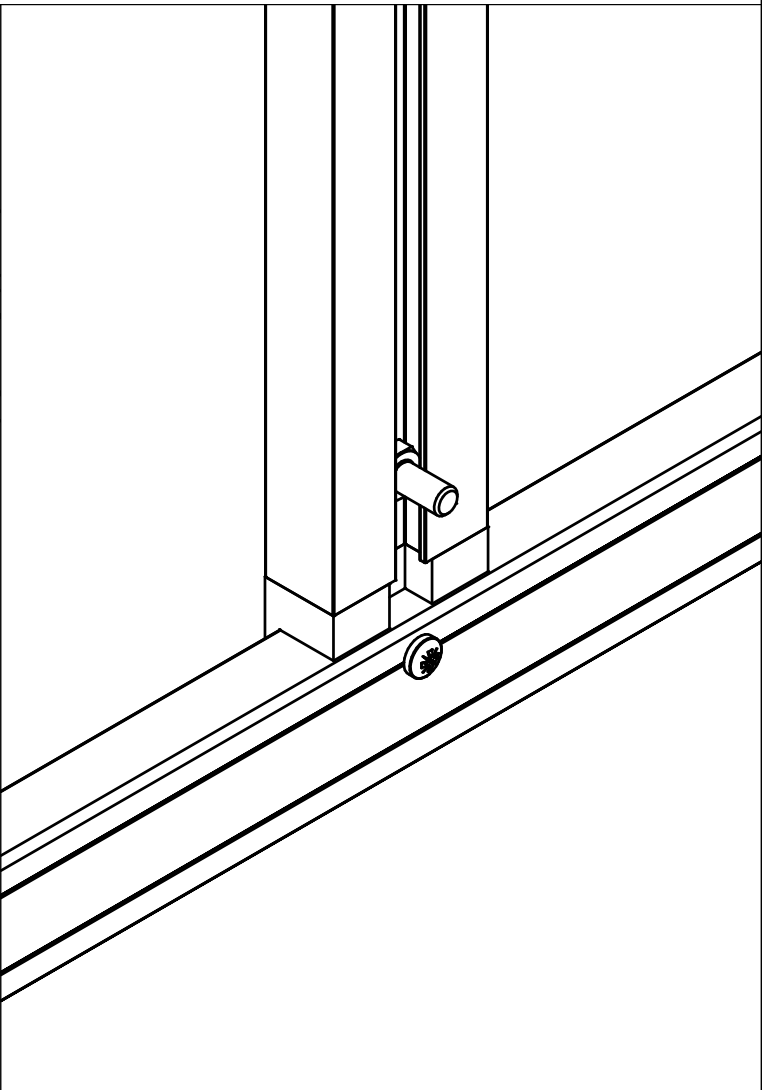
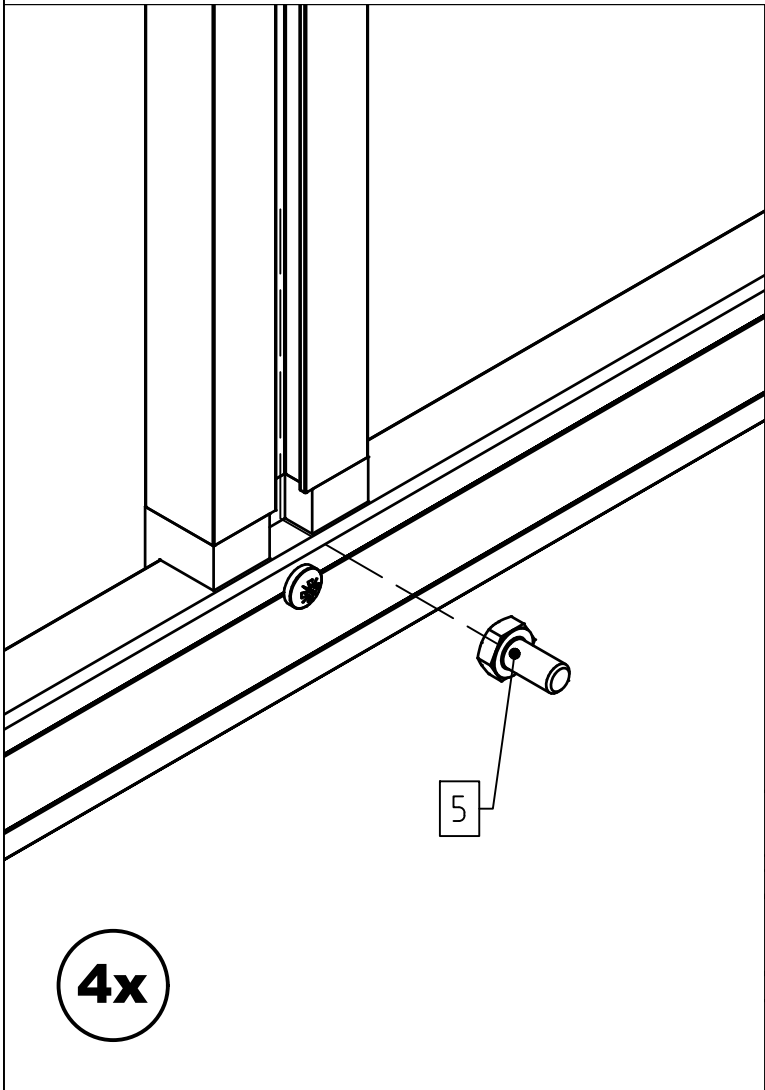
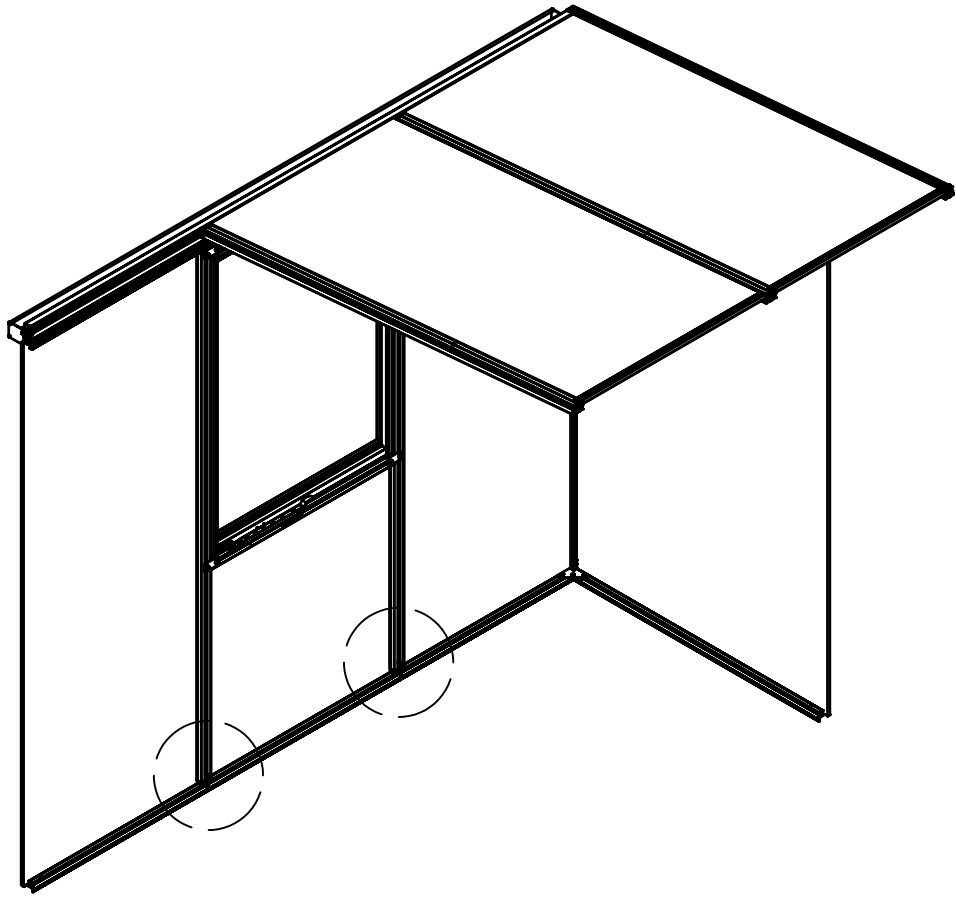

4x

VD

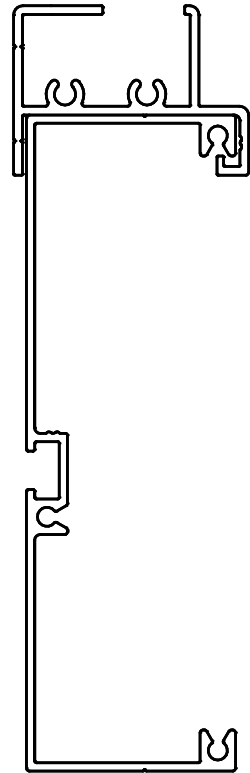
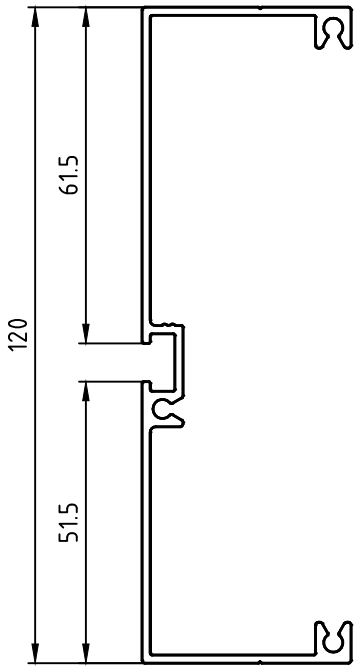
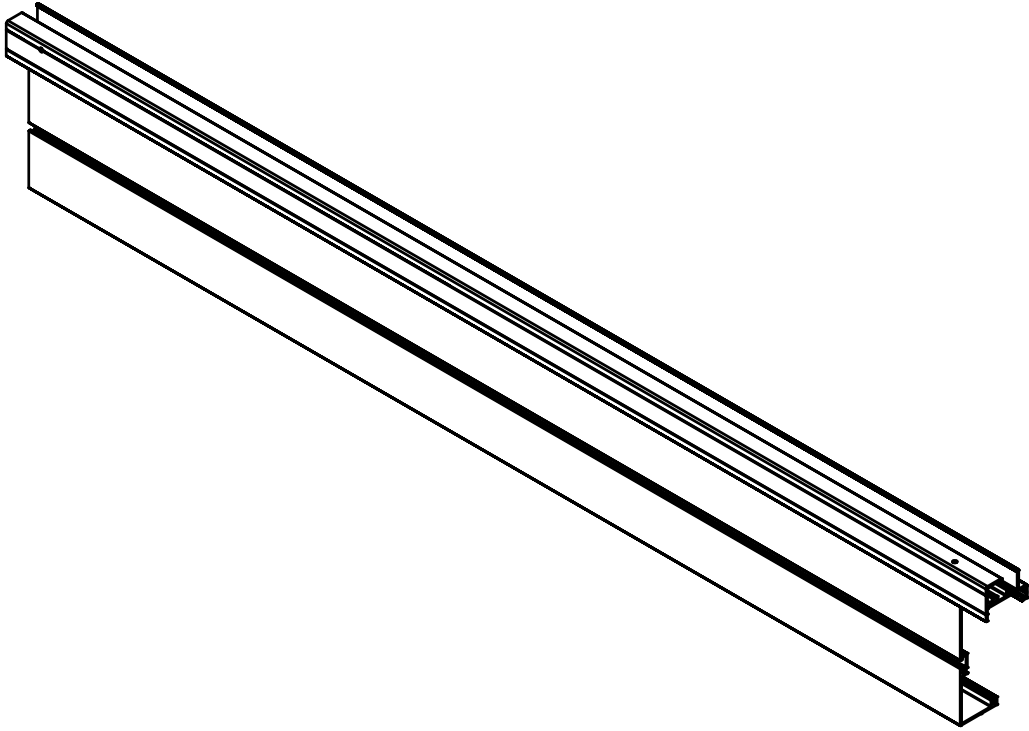

4x

I

VD

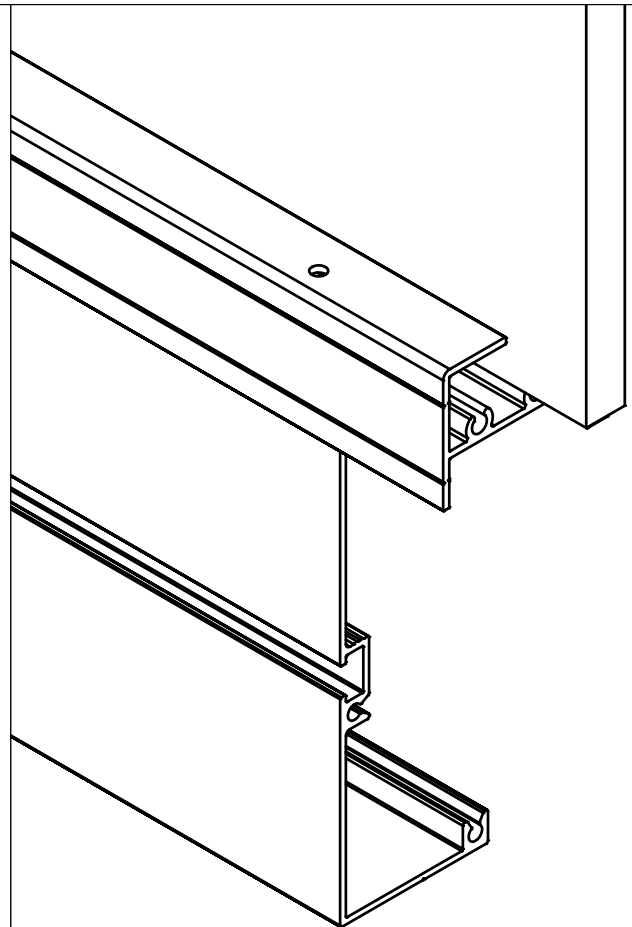
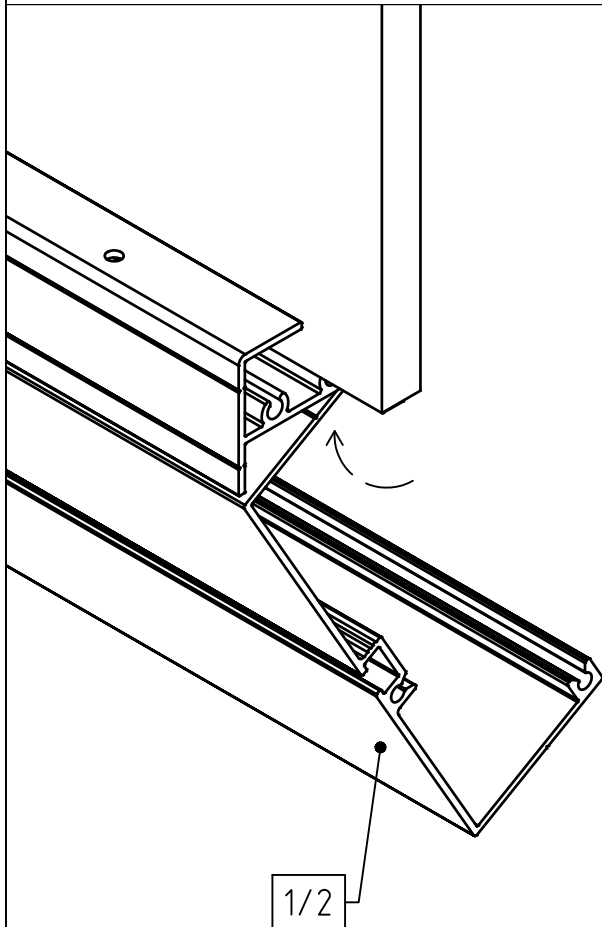
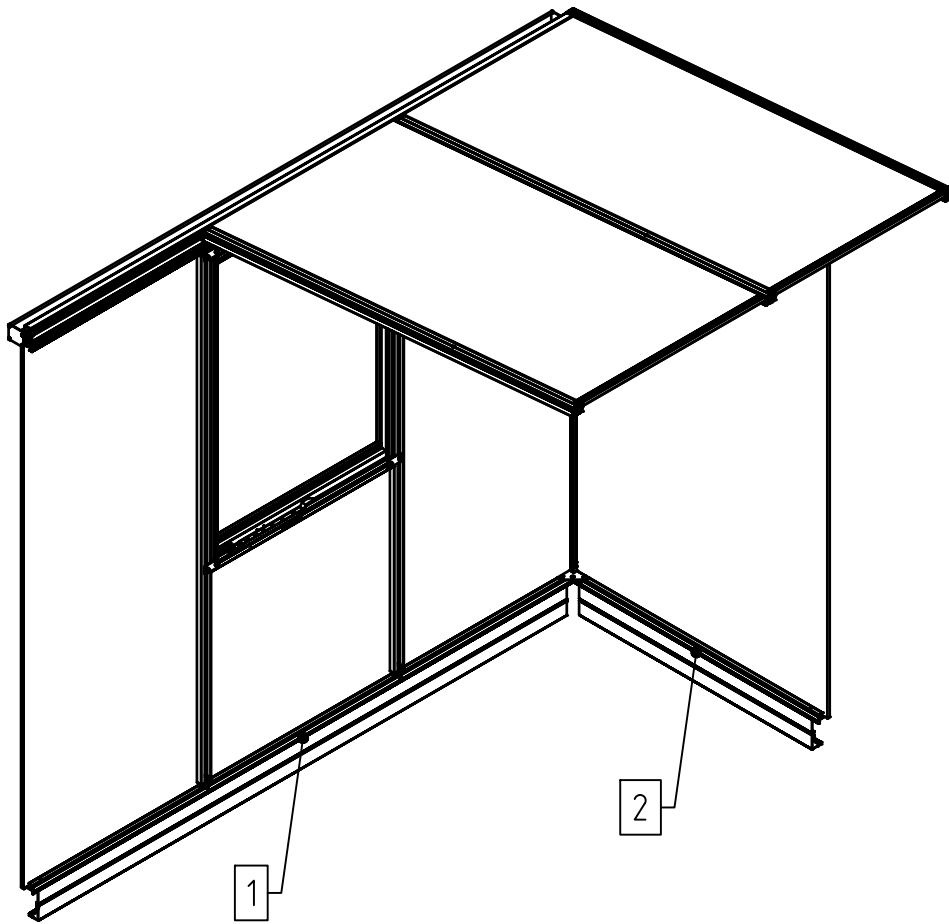

4x

I

VD

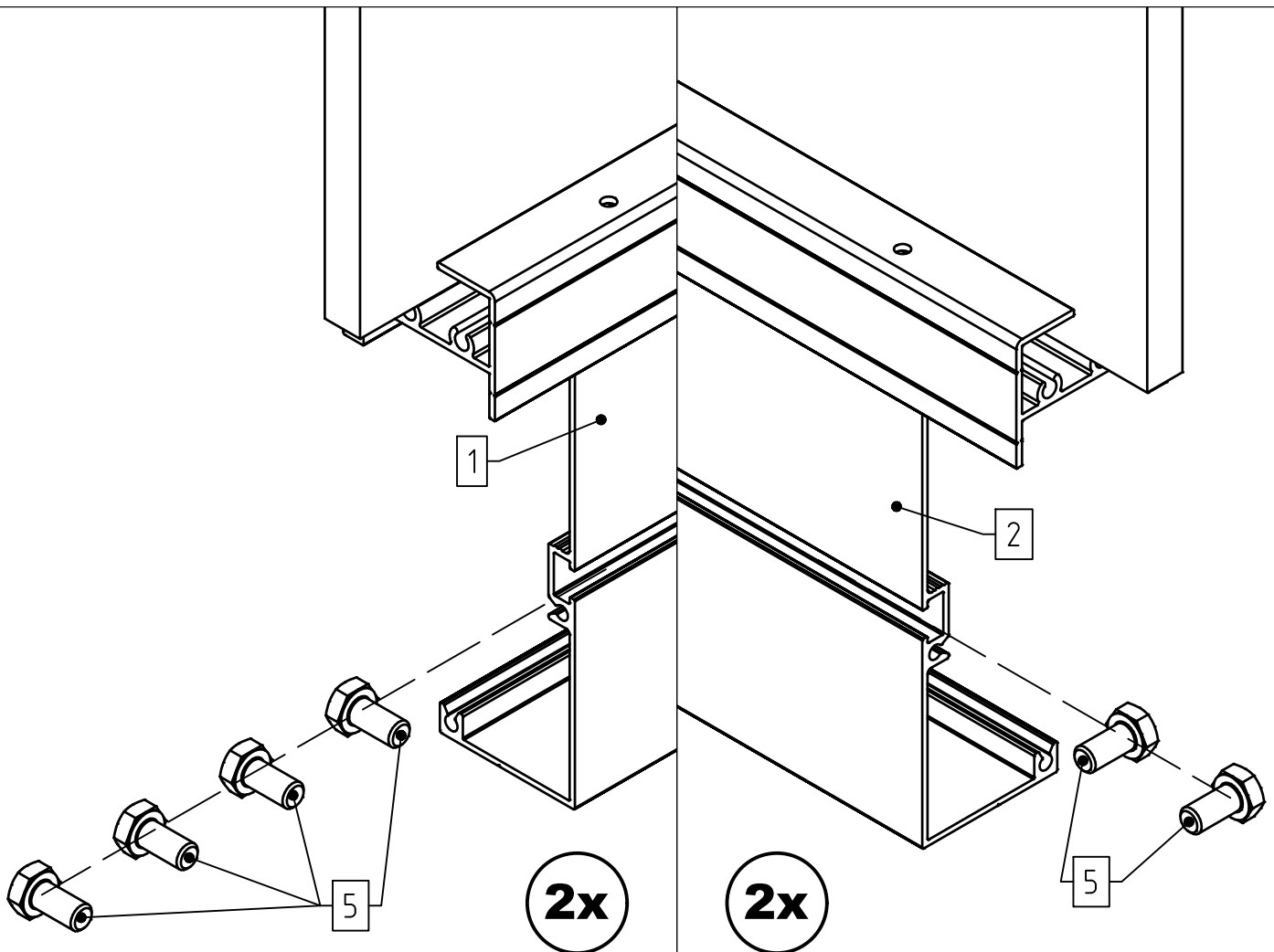
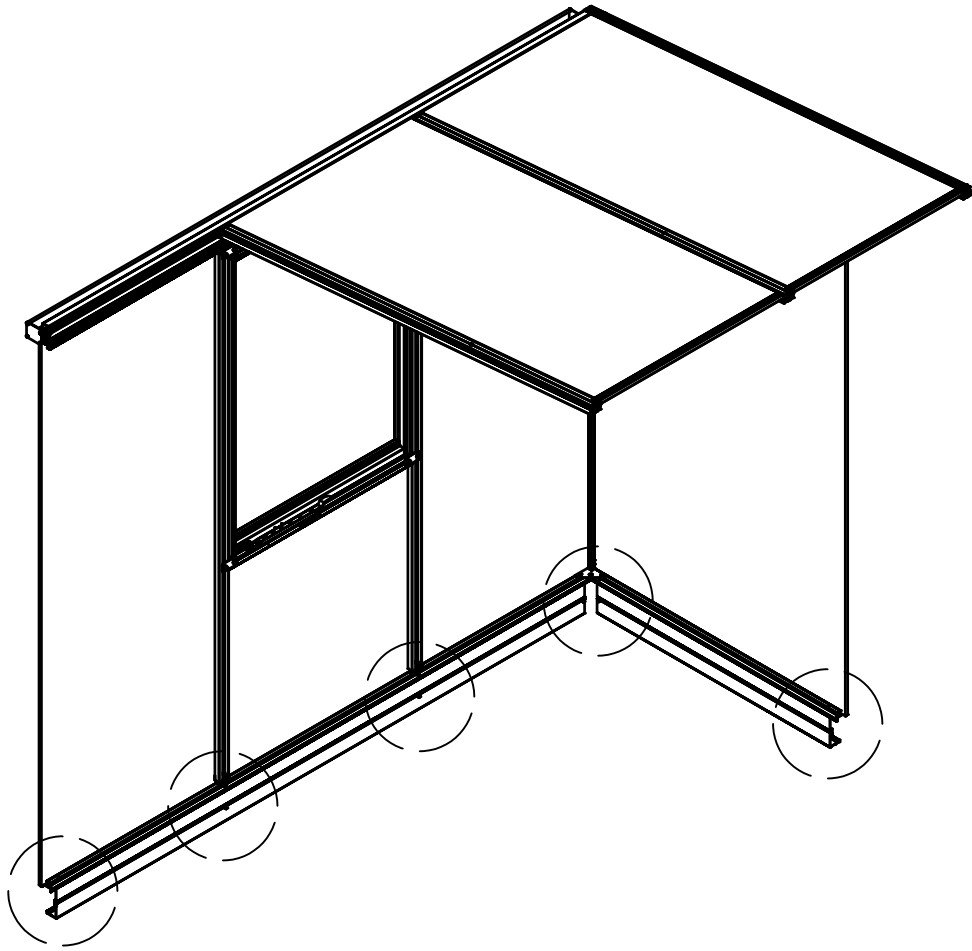

I

VD

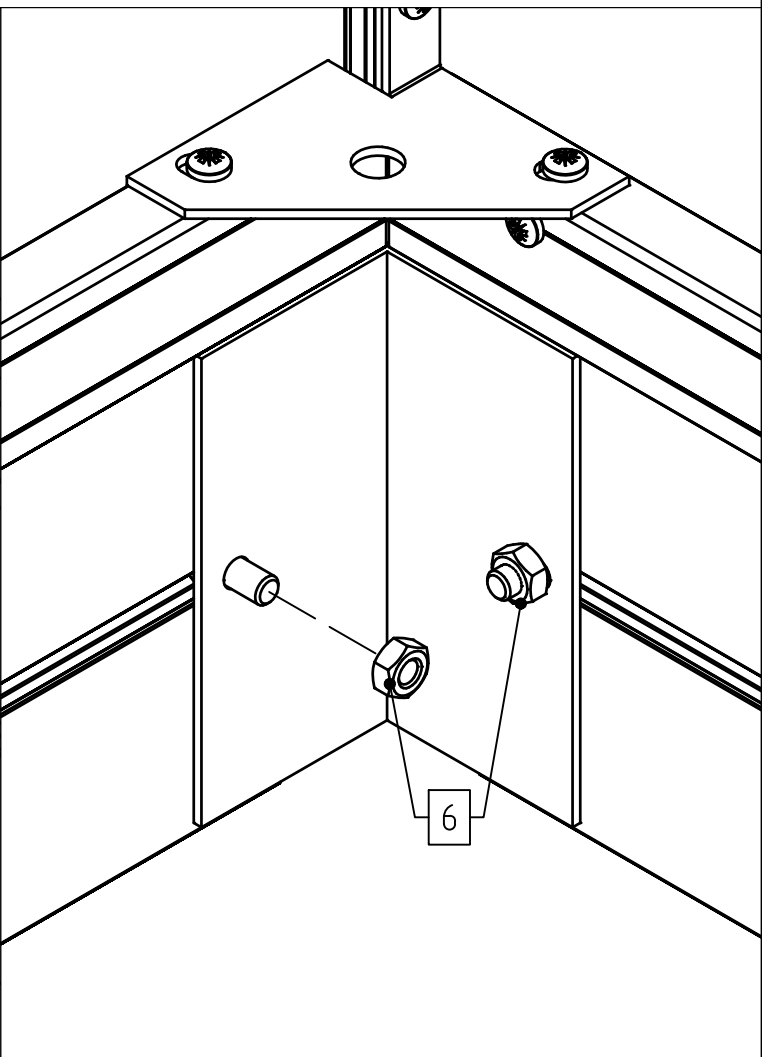
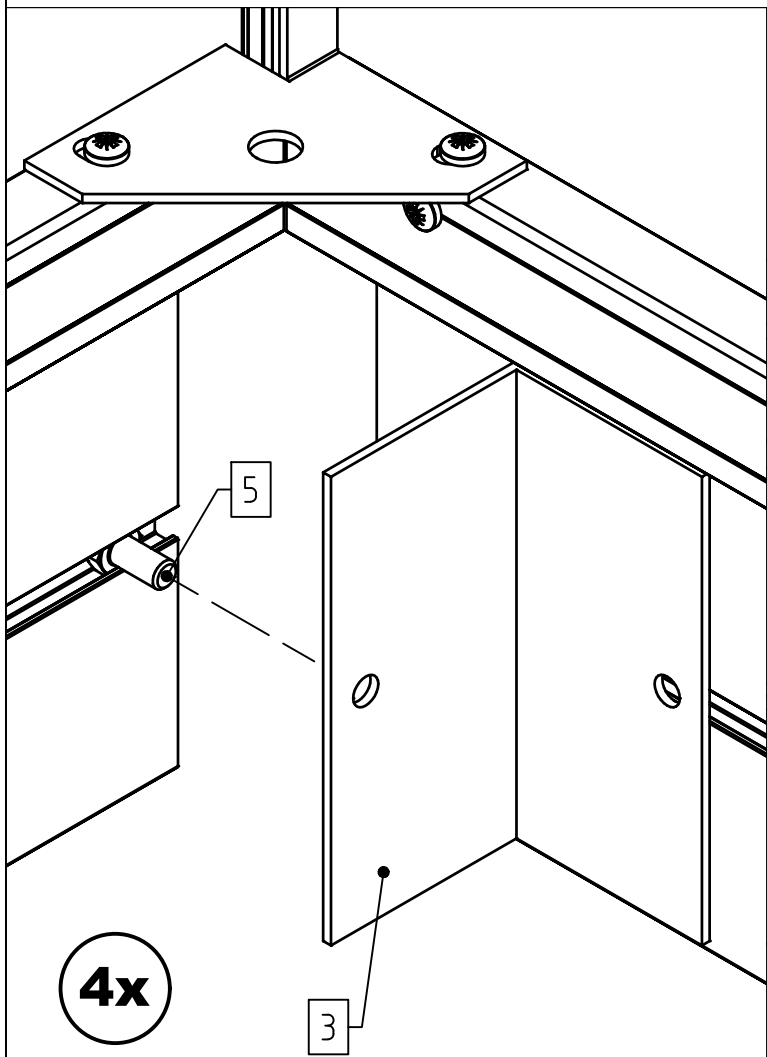
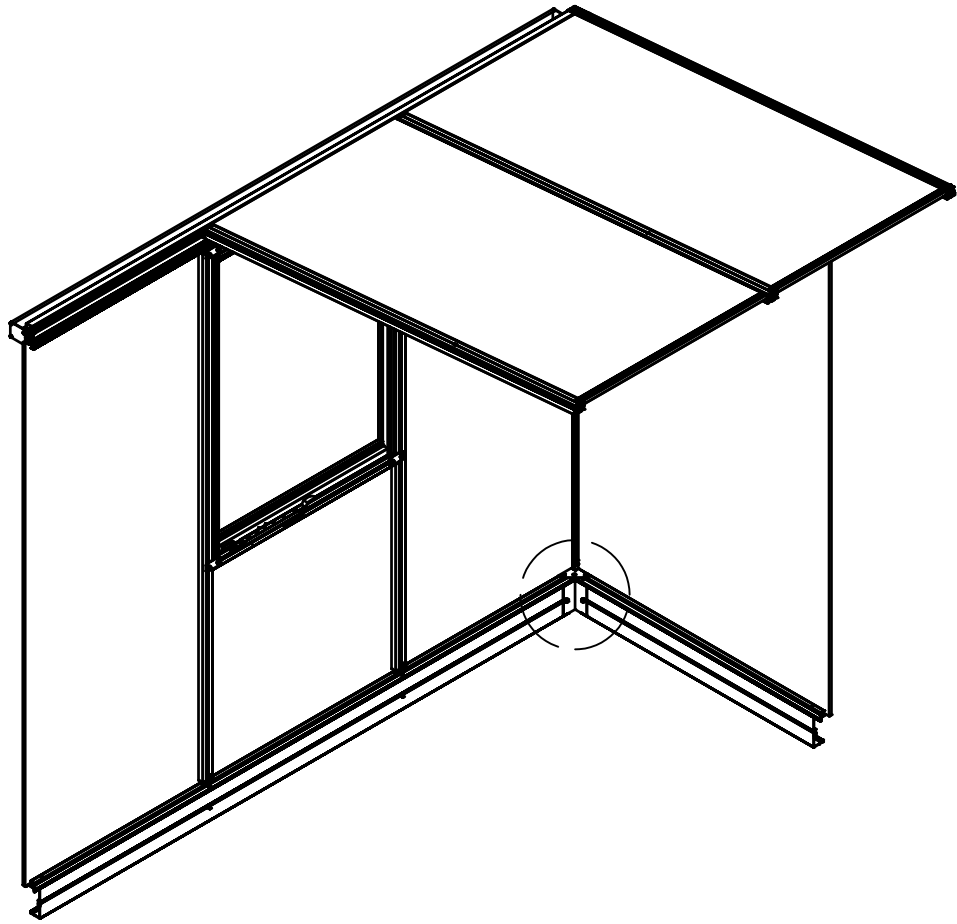

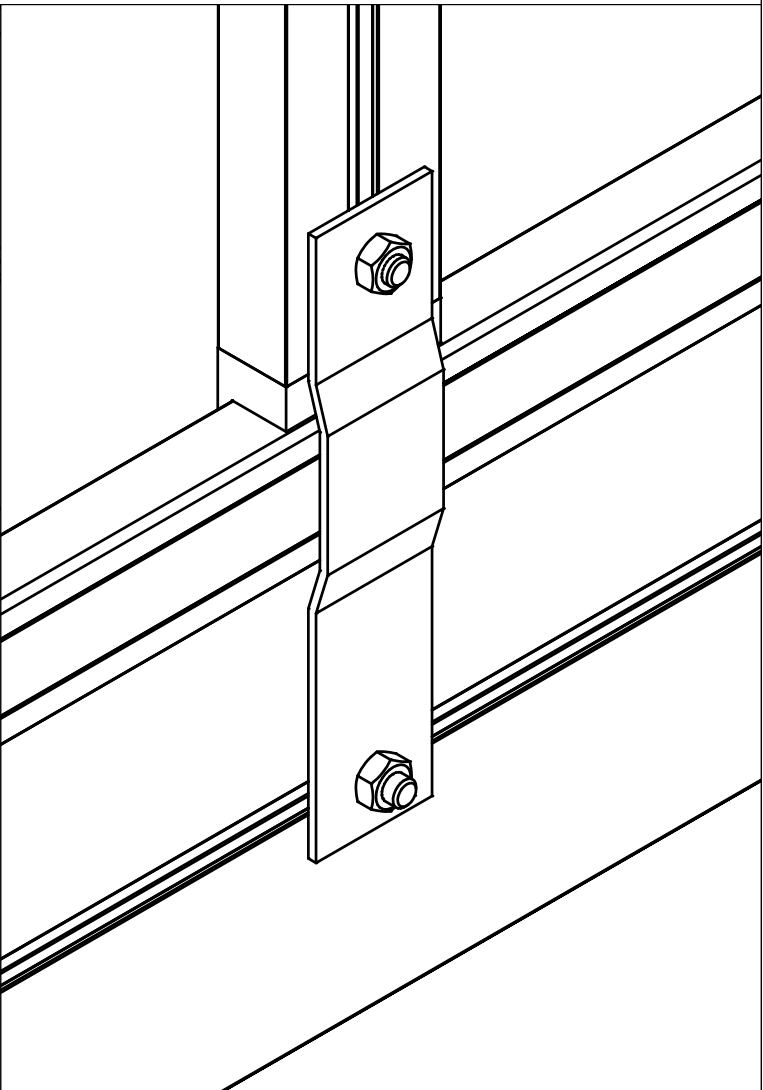
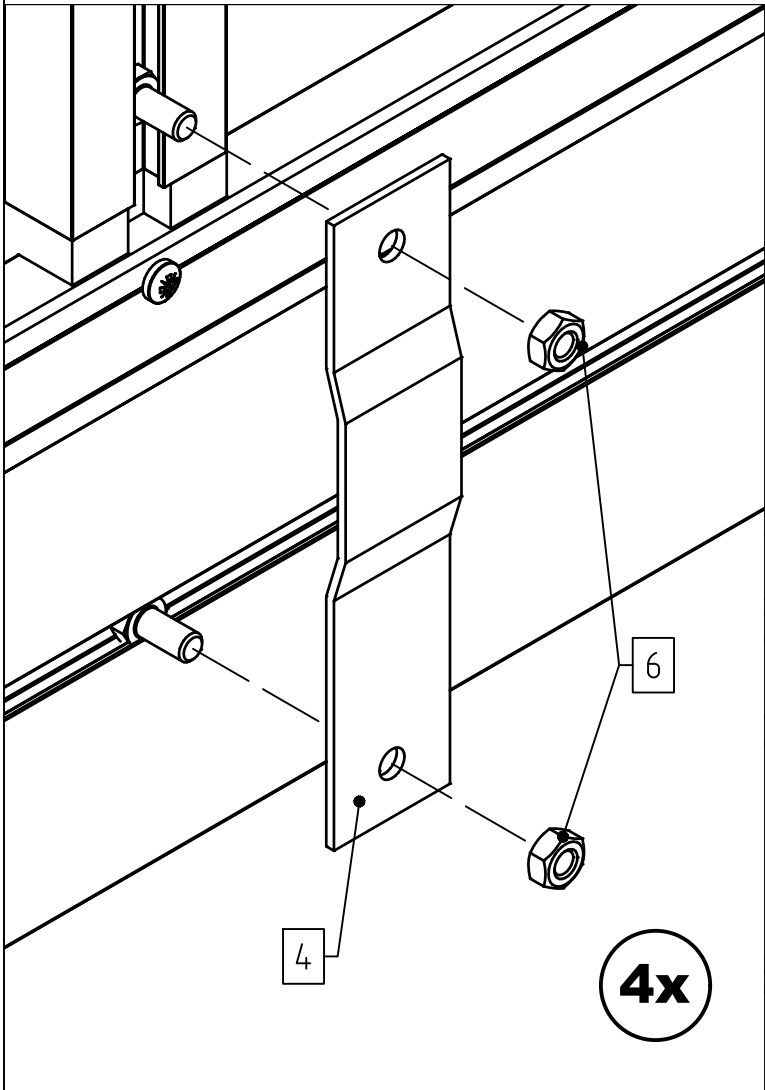
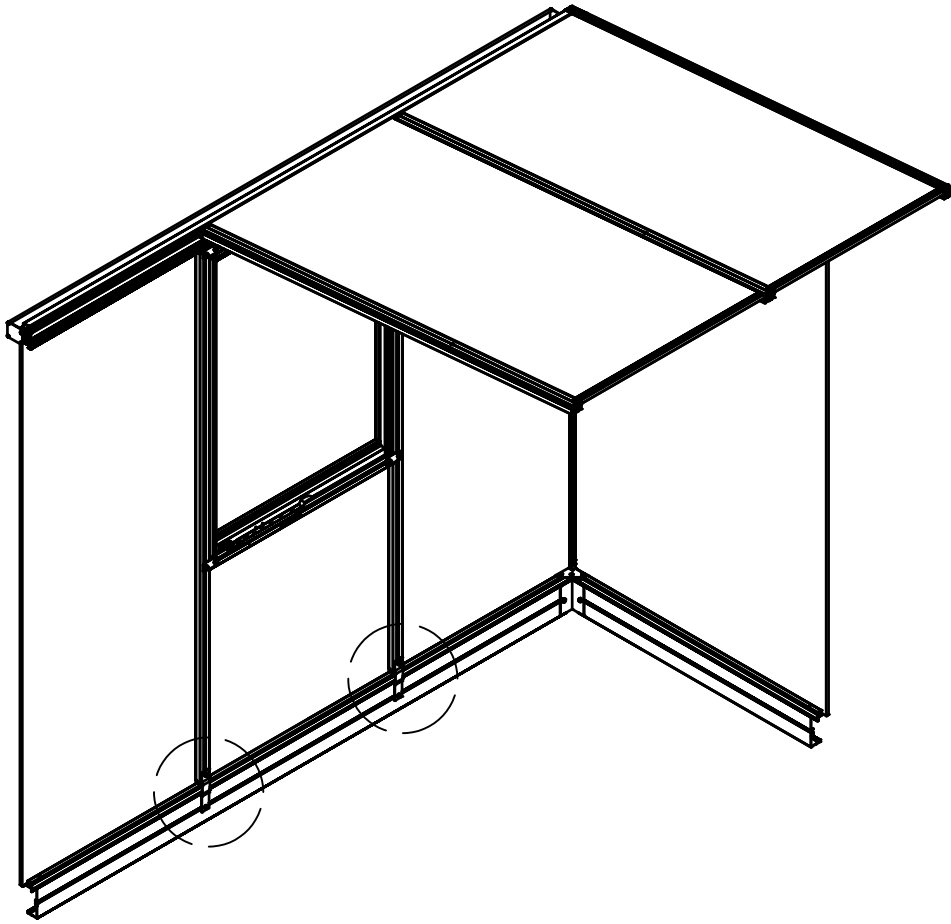

I

VD

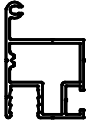
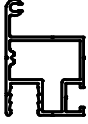
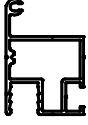
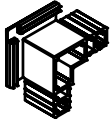

STÜCKLISTE

Oberlicht Linea I

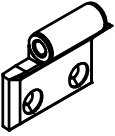
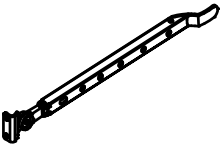
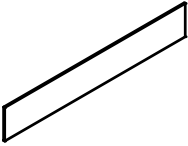
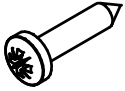
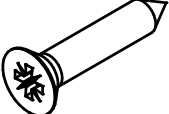
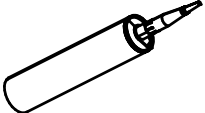
Pos.	Abbildung	Art.-Nr.	Bezeichnung	Anzahl	Bemerkung
1		P082-09-01-00-04-1	Fensterprofil 10 mm Oben	2	635 mm
2		P082-10-01-00-04-1	Fensterprofil 10 mm Unten	2	635 mm
3		P082-04-01-00-04-1	Fensterprofil 10 mm Seite	4	83 mm
4		9999000005	Eckverbinder Dachfenster 10mm	8	
5		9999000023	Vorreiber	2	
6		9999000070	Verbindungswinkel 30 x 30 x 4 mm (mit Madenschraube)	8	
7		9999000358	Scharnieroberteil (inkl. Buchsen)	4	
8		9999000390	Fensteraufsteller	2	
9			PC-Hohlkammerplatte 656 x 105 mm	2	
10		9999000135	Linsenkopfschraube 3,5 x 16	8	DIN 7981
11		9999000163	Senkkopfschraube 4,8 x 25	8	DIN 7982
12		10109413	Silikonkartusche	1	

STÜCKLISTE

Oberlicht Linea I

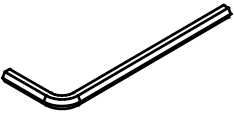
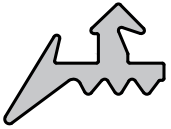
Pos.	Abbildung	Art.-Nr.	Bezeichnung	Anzahl	Bemerkung
13		9999000056	Sechskantstiftschlüssel SW3	1	DIN 911
14		9999000376	Sprossendichtung 2mm	4,0 lfdm.	
15					
16					
17					
18					
19					
20					
21					
22					
23					
24					

1

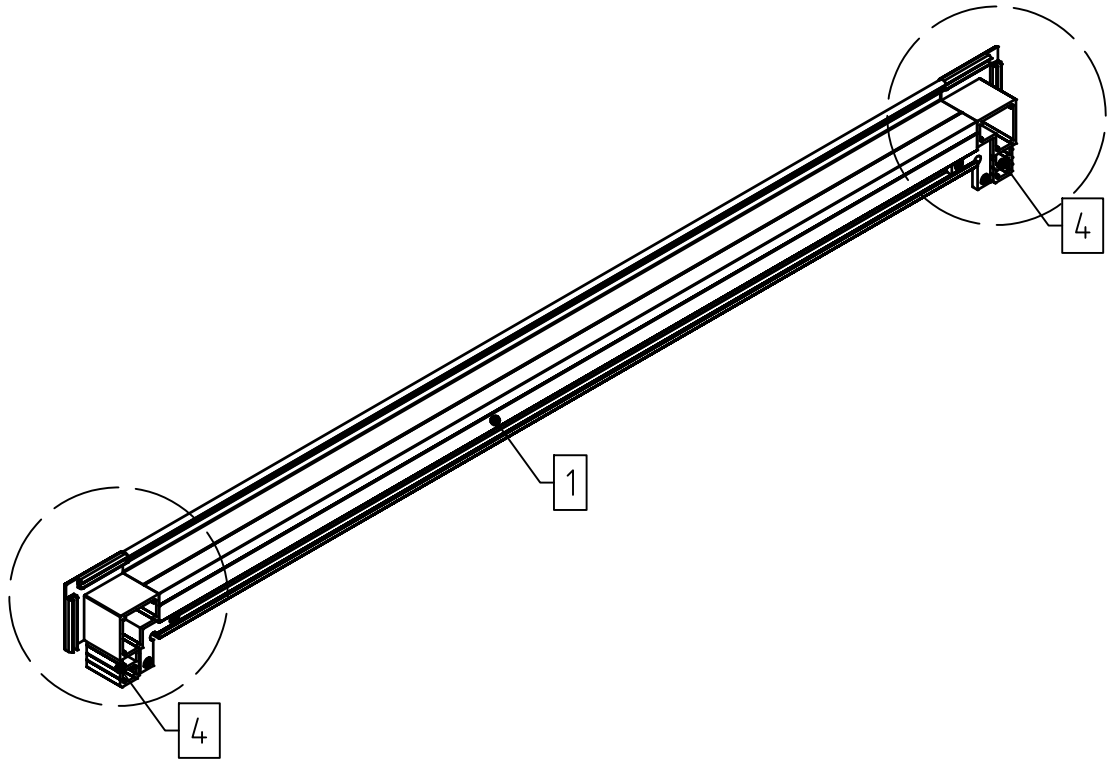

2x

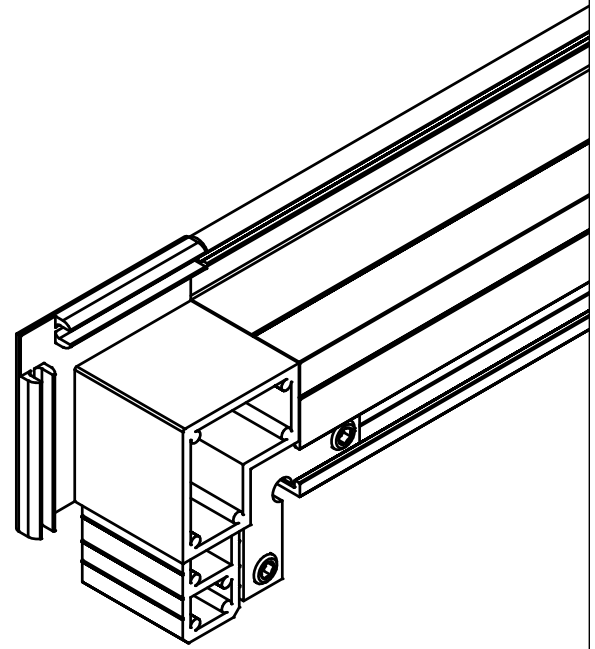
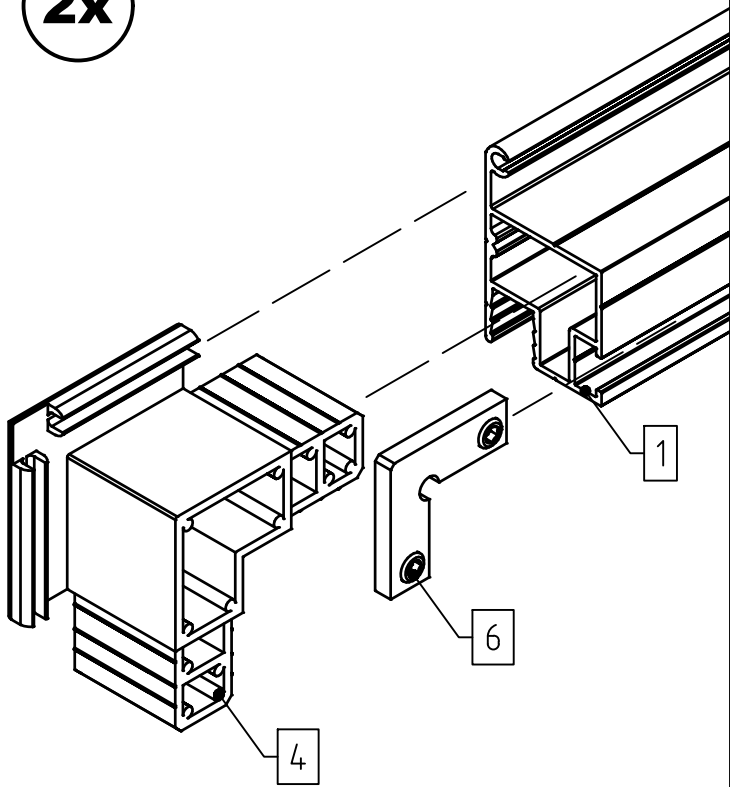

1

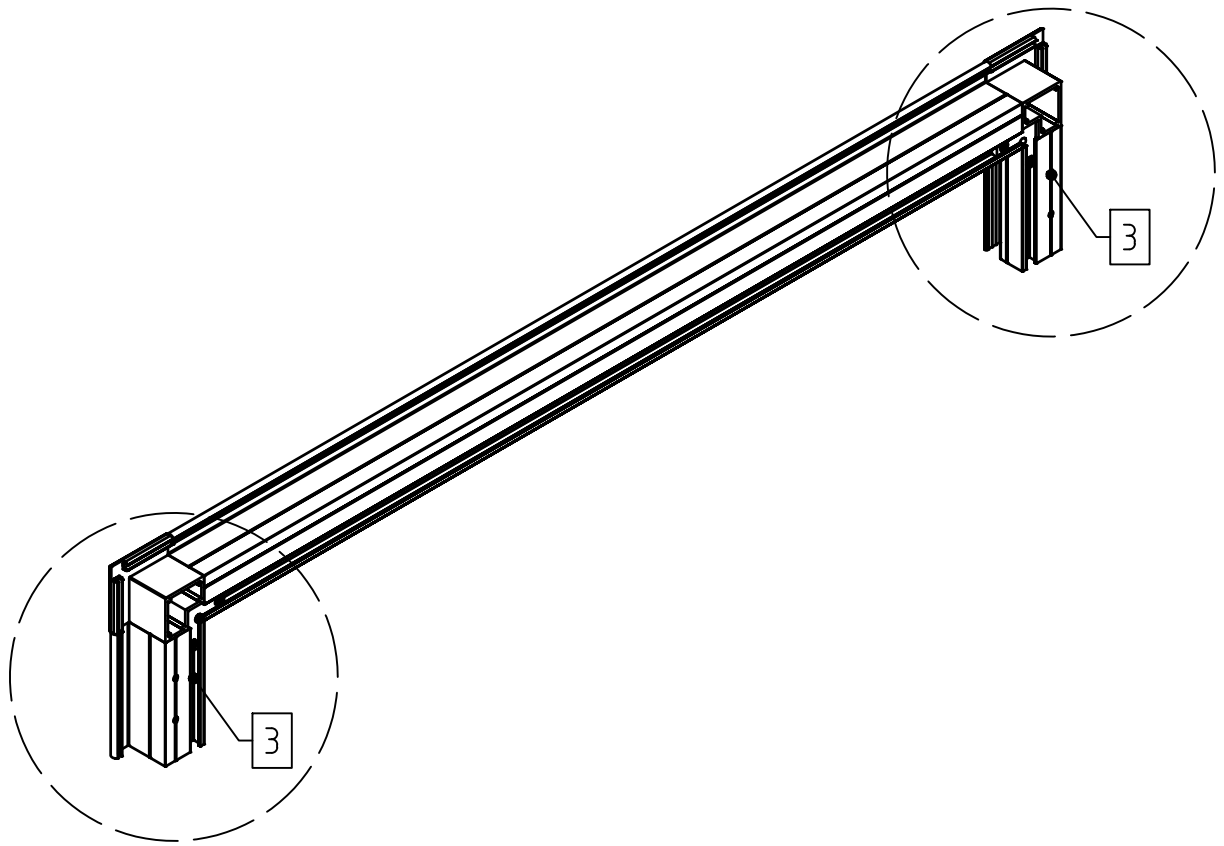

2x

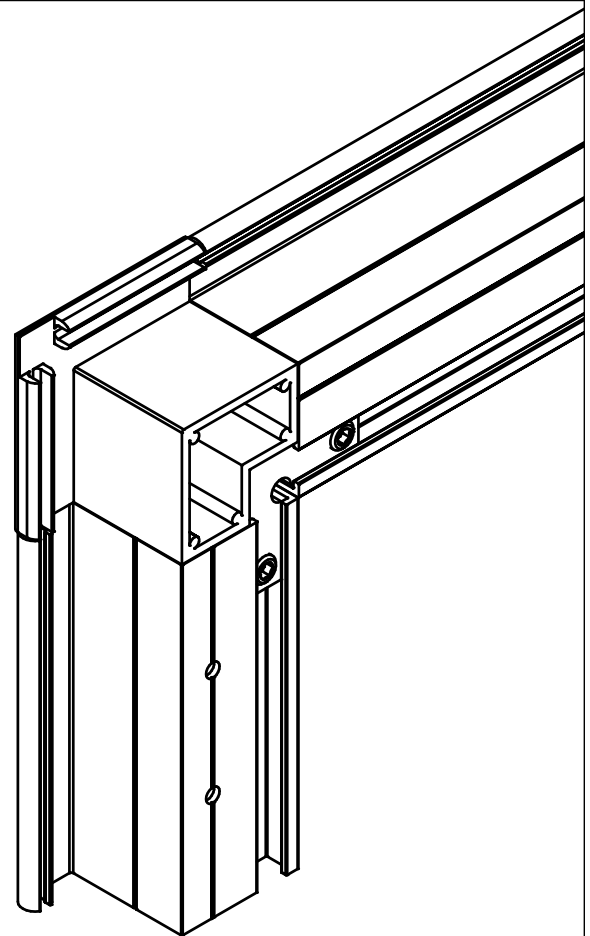
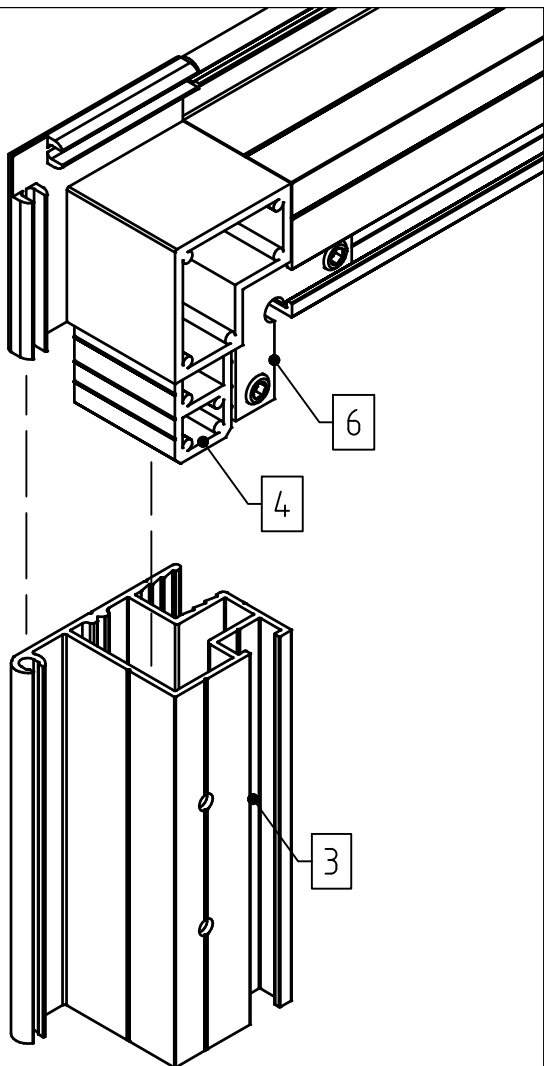

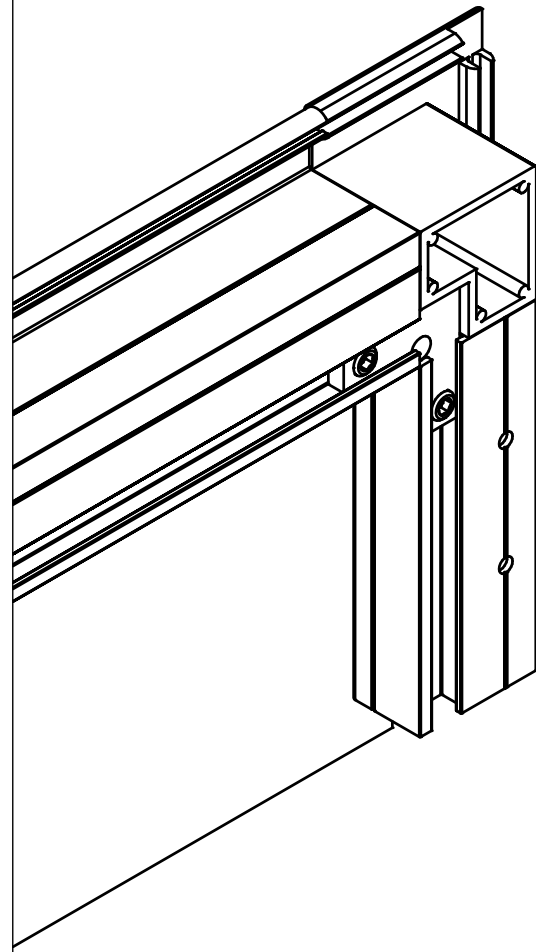
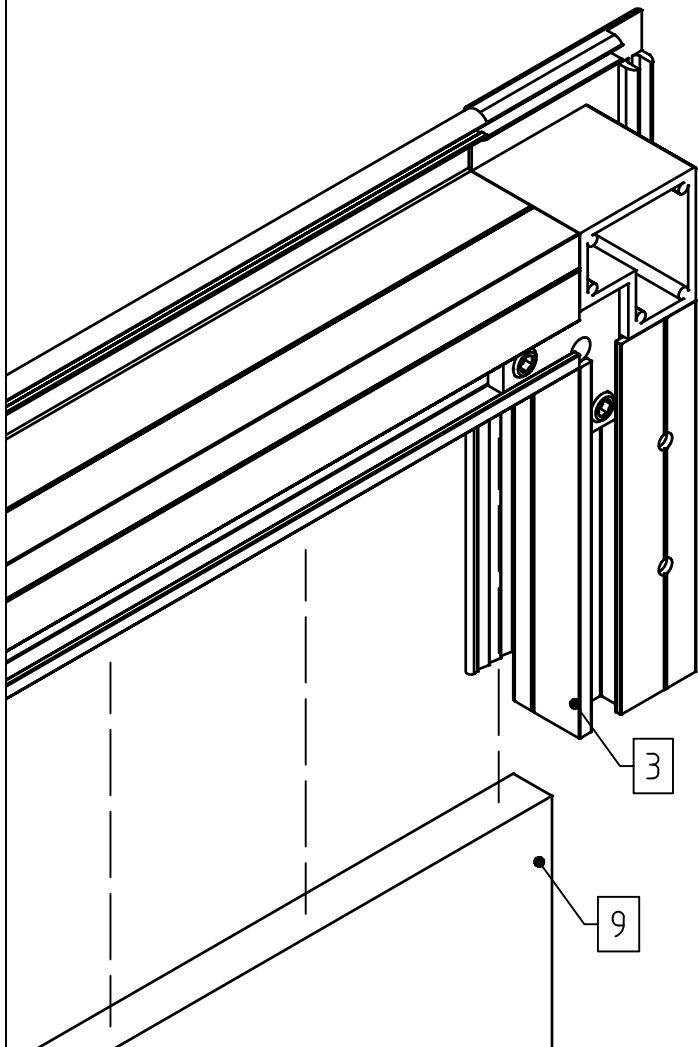
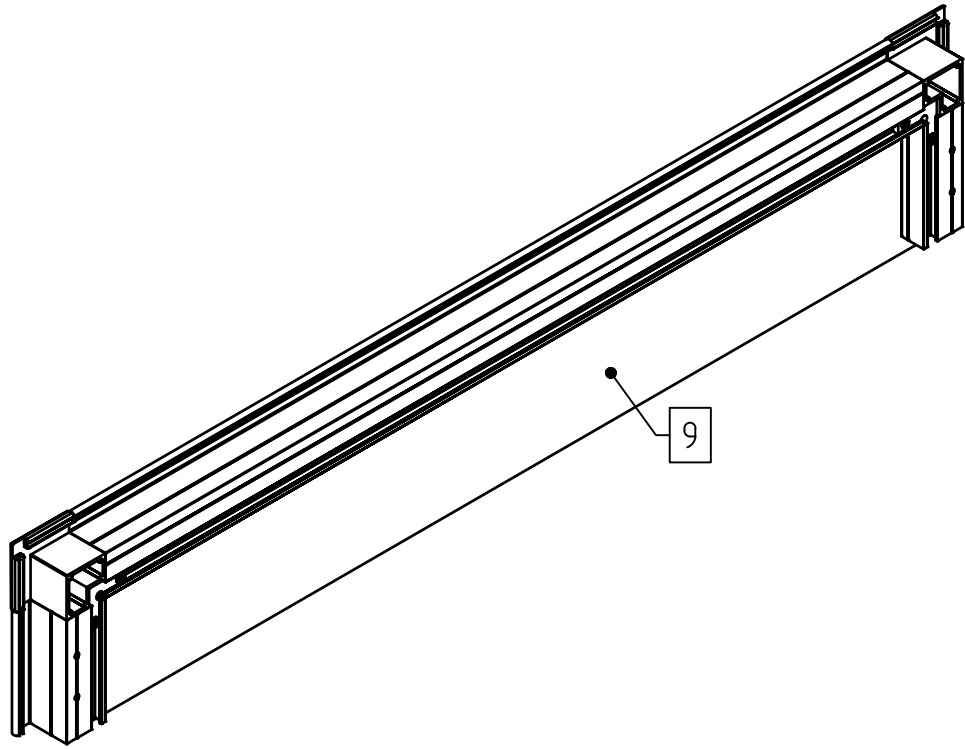

1

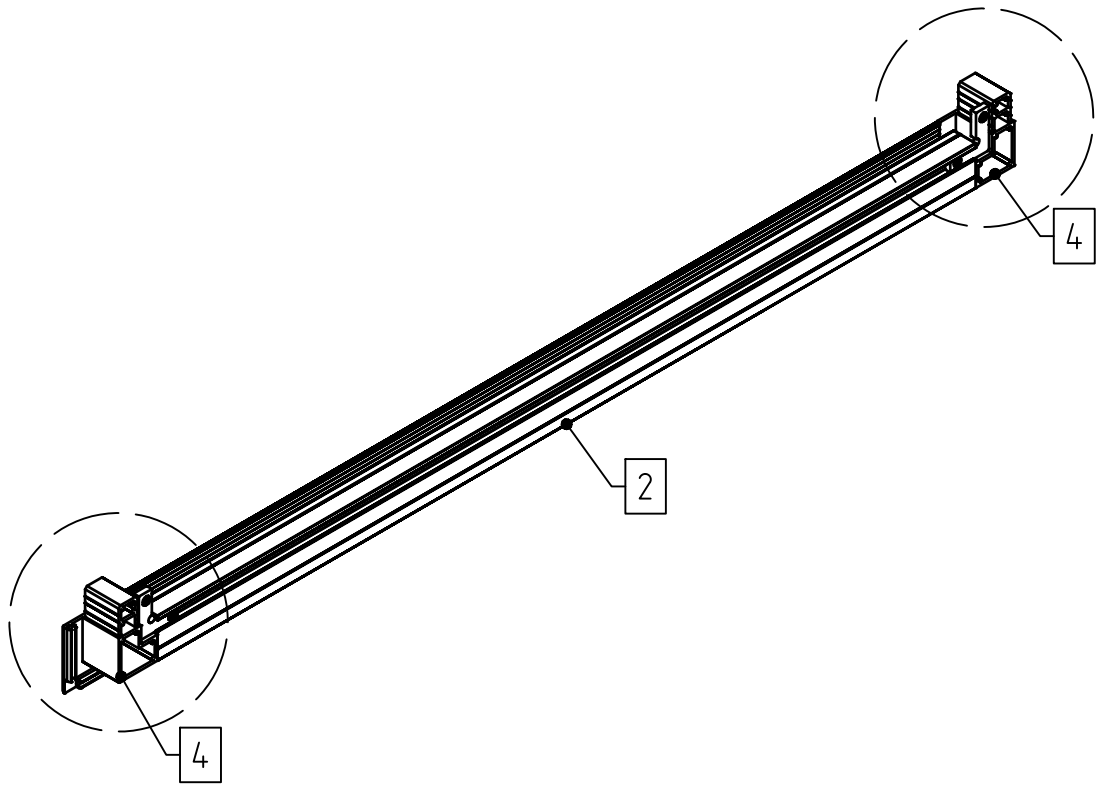

2x

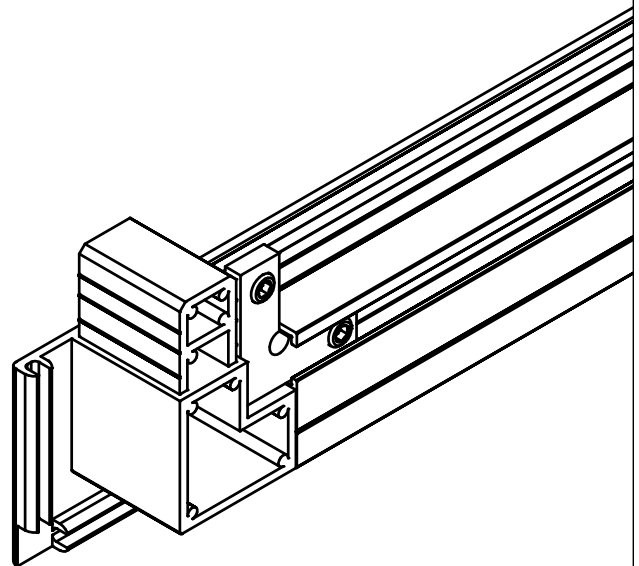
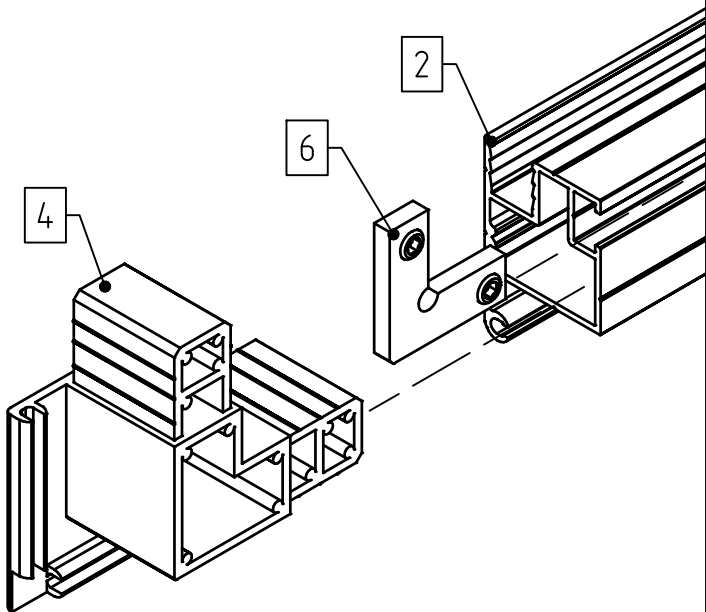

1

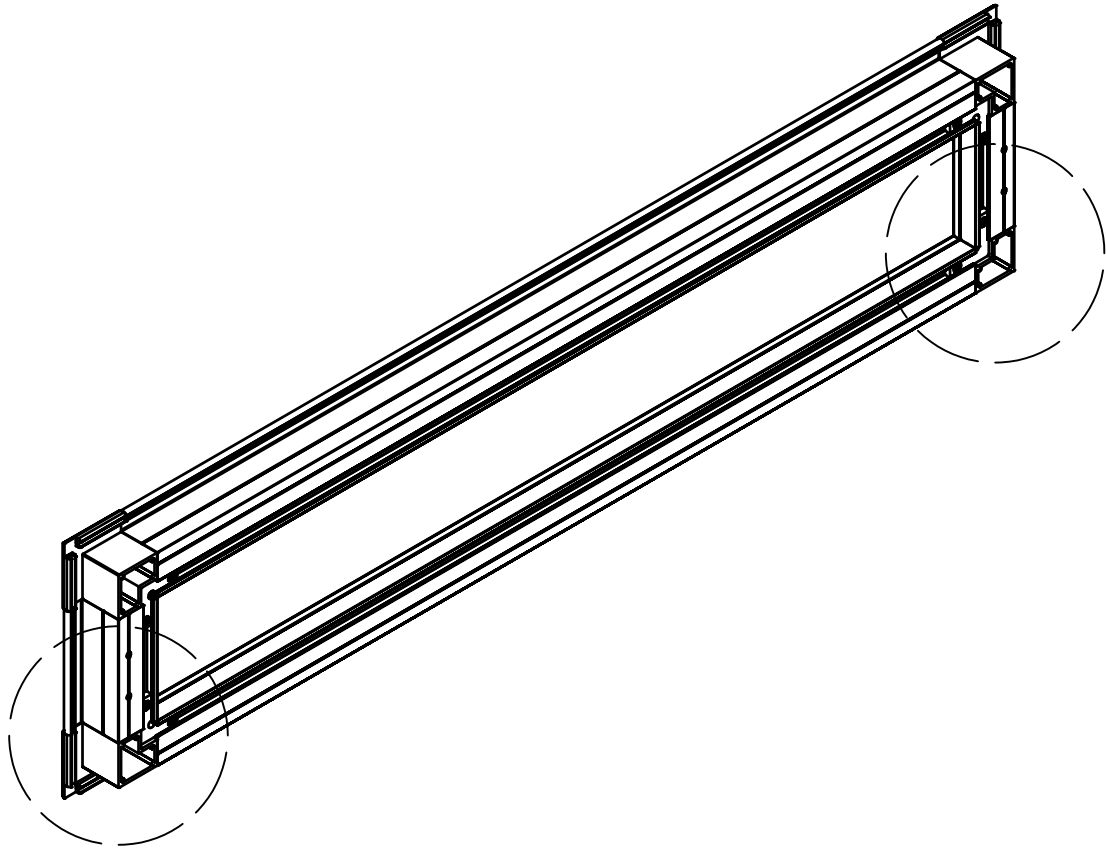

2x

3

4

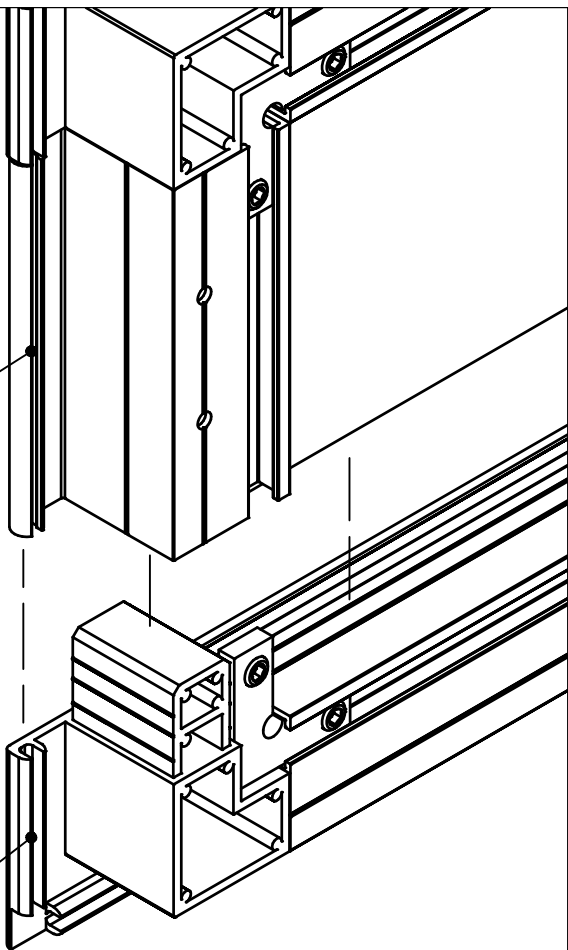

8x

13

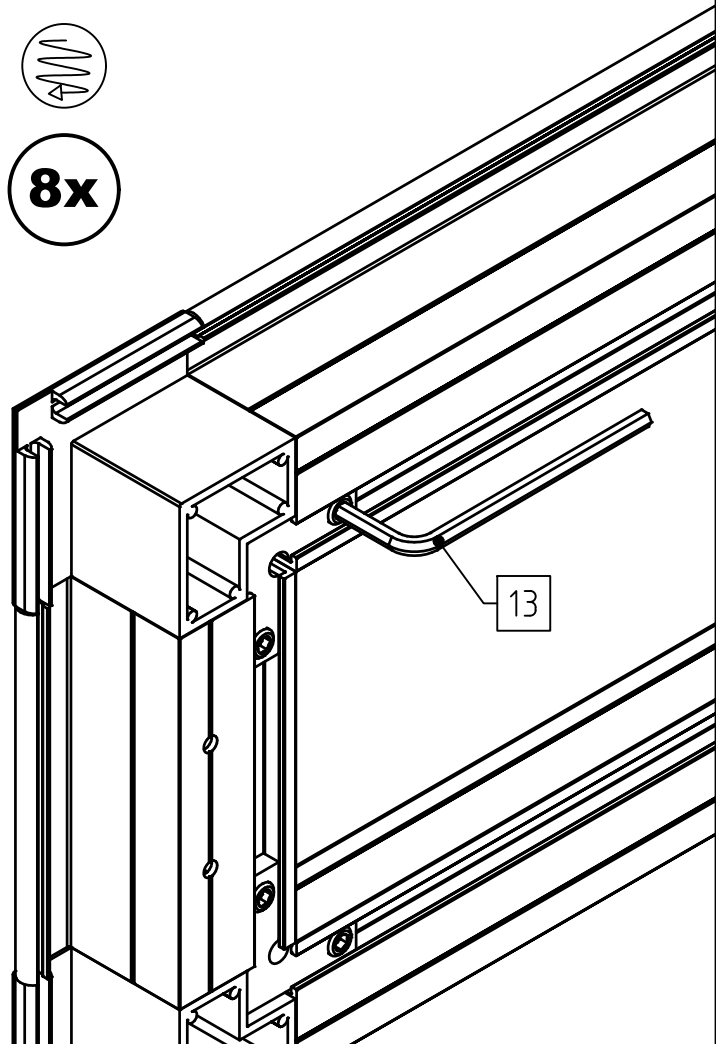

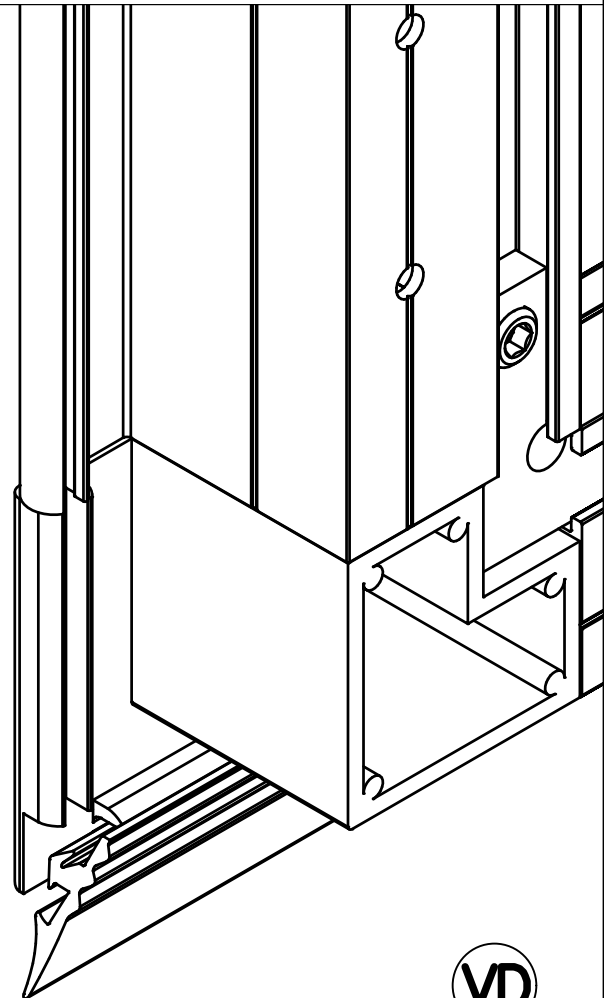
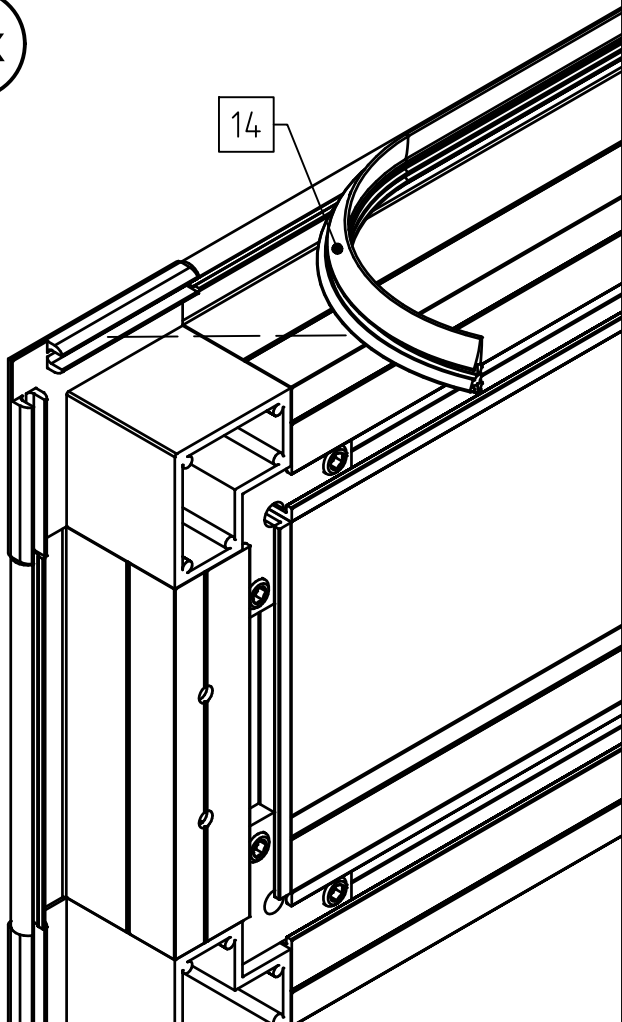
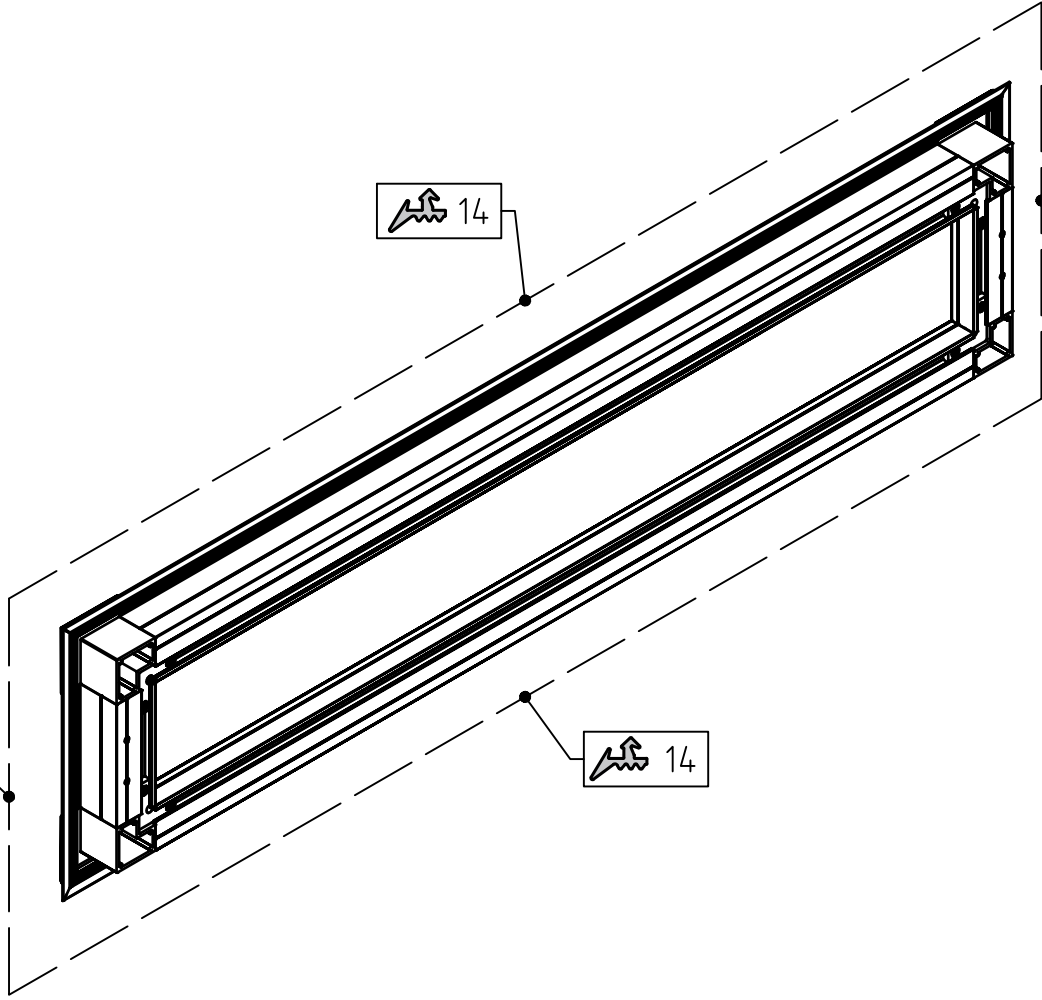

A

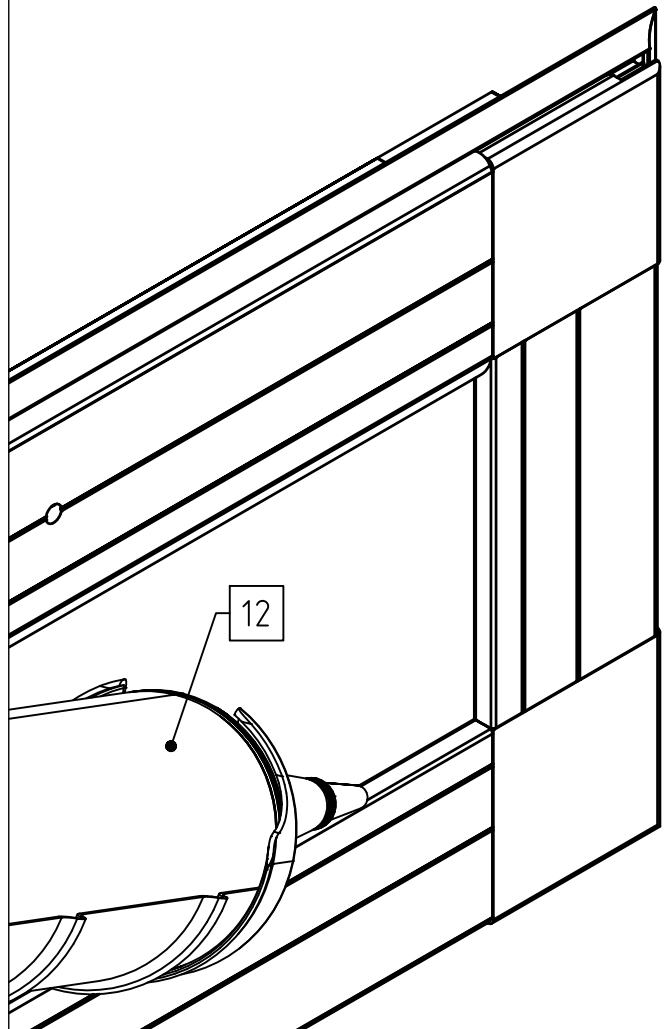
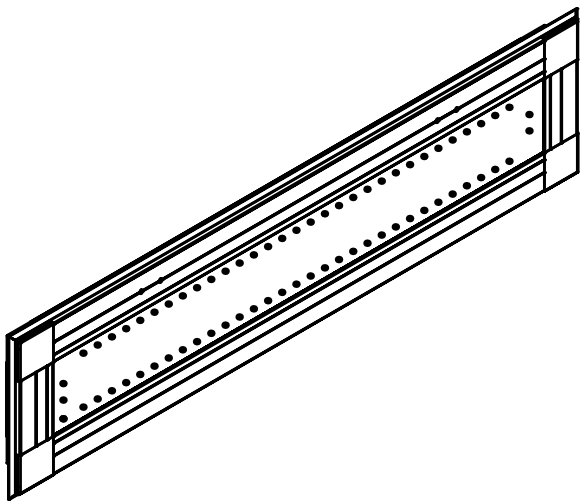
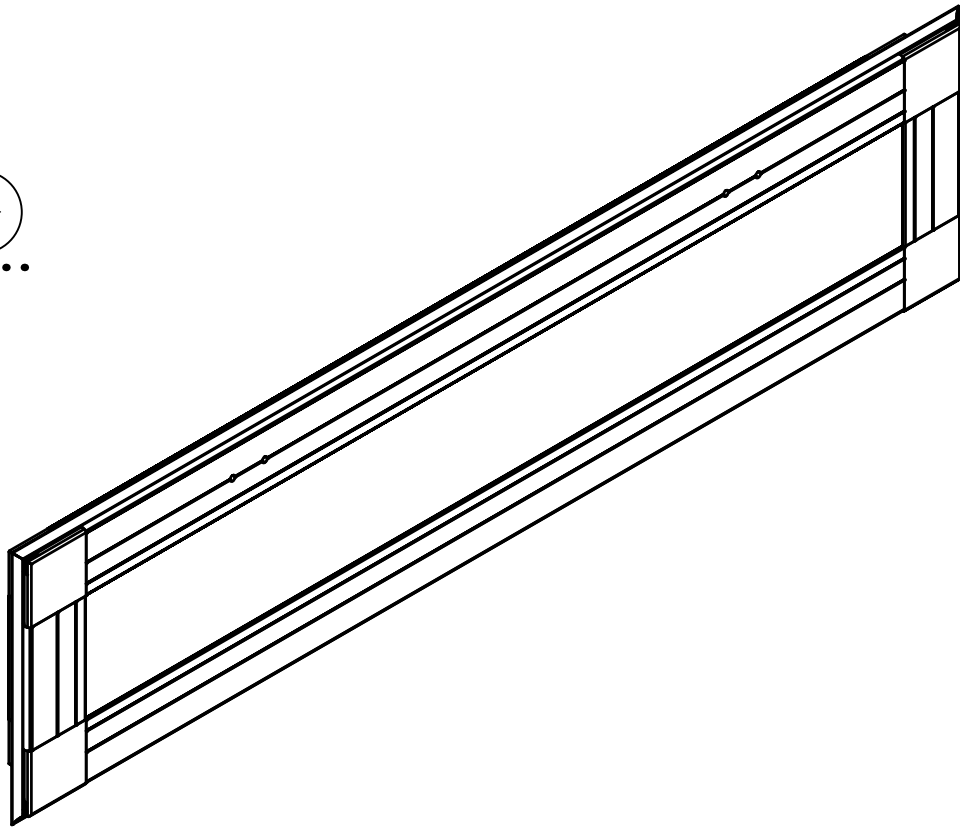
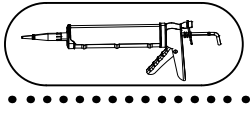

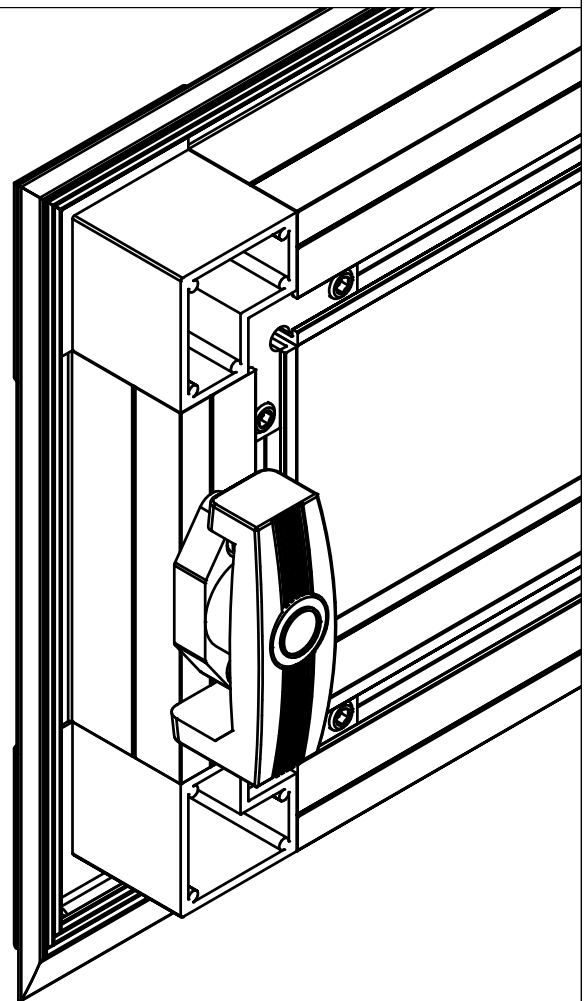
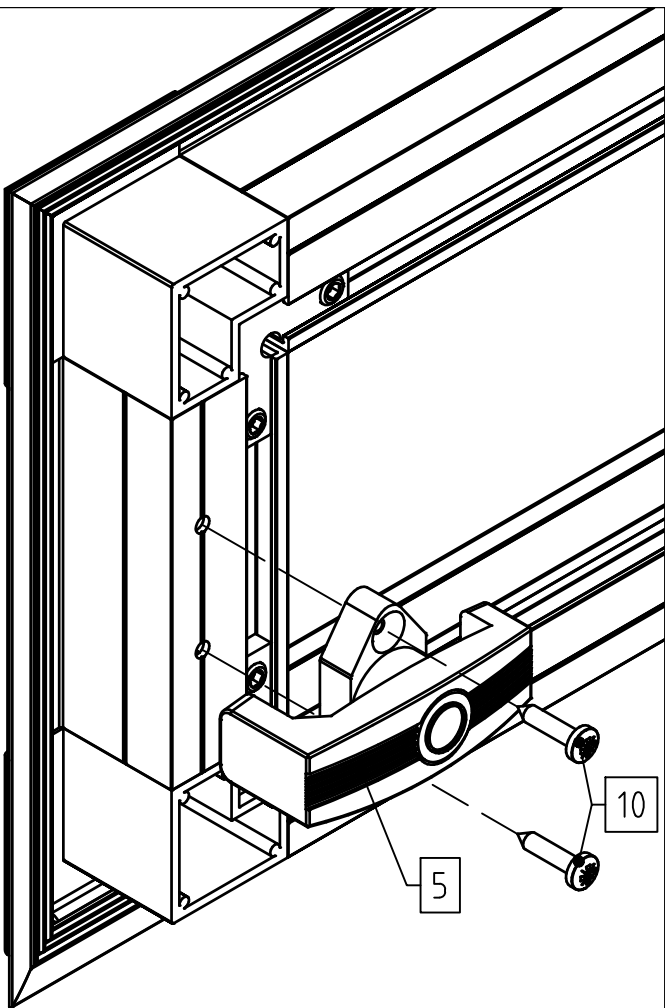
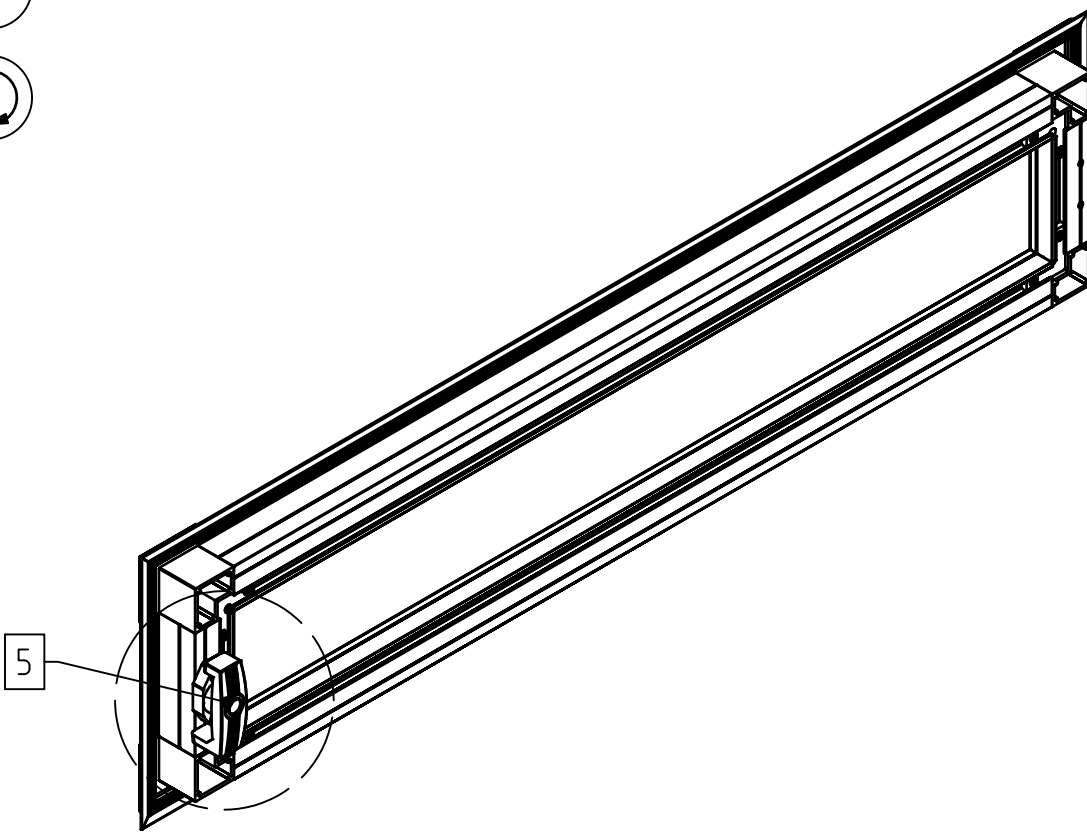

1

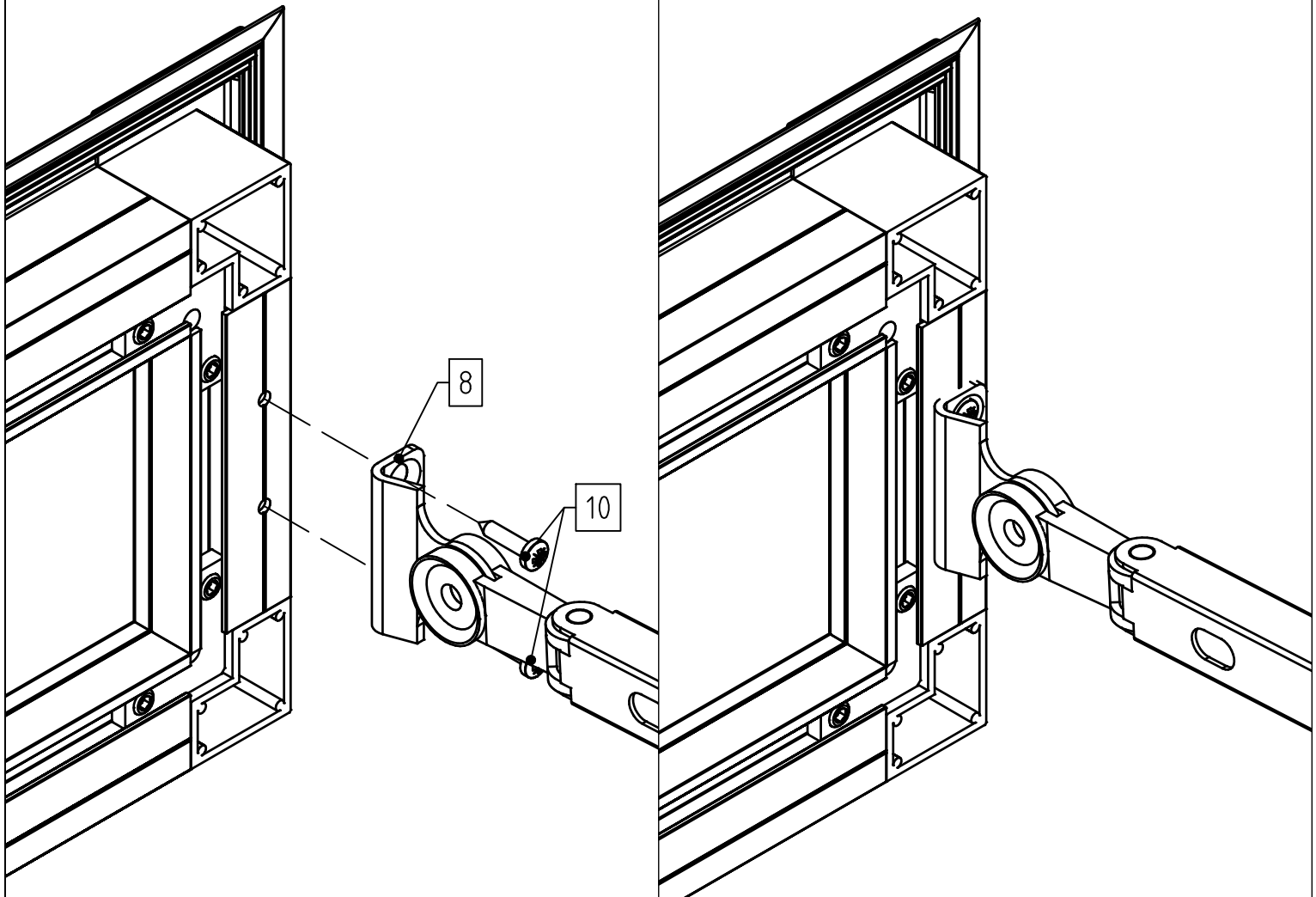
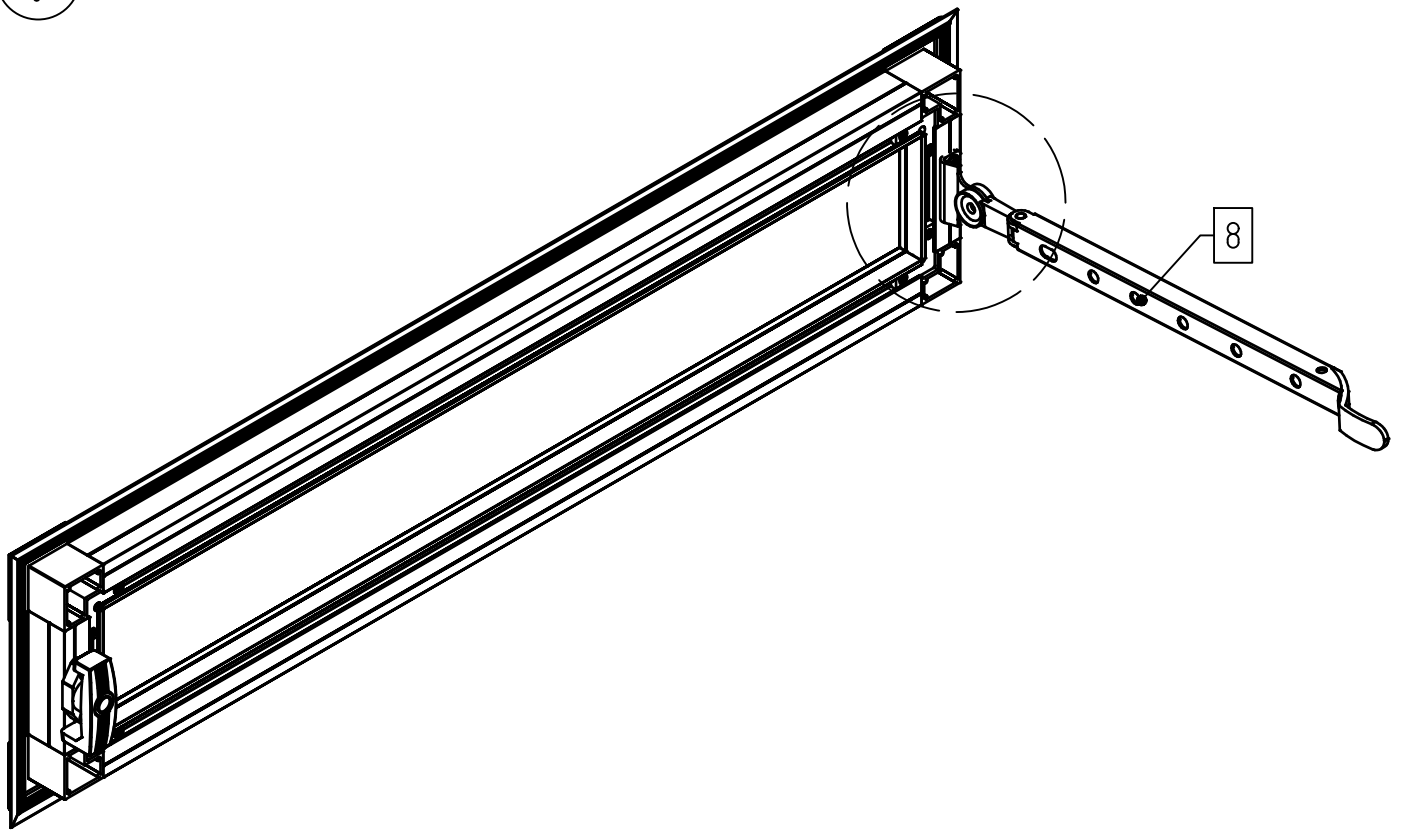

A

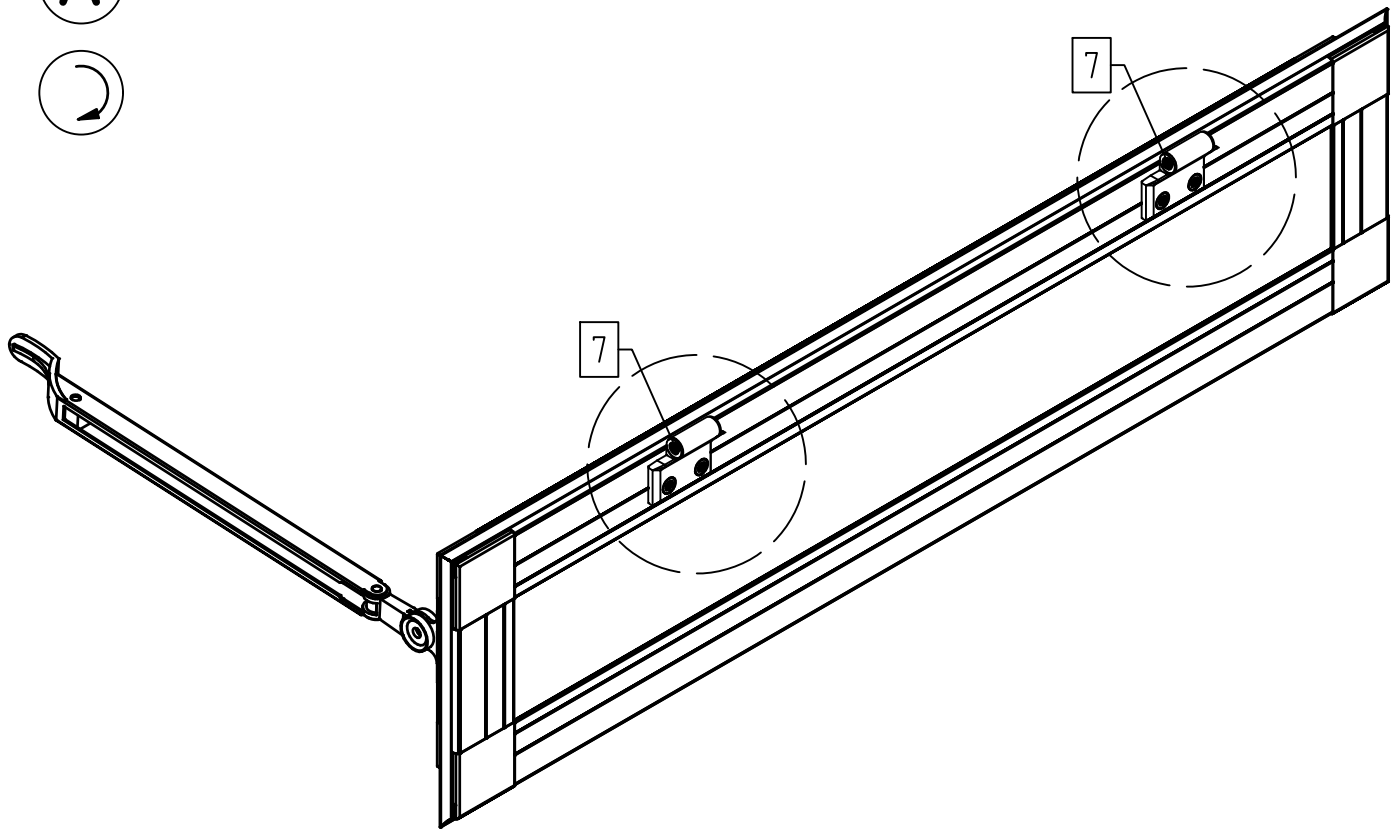

L

2x

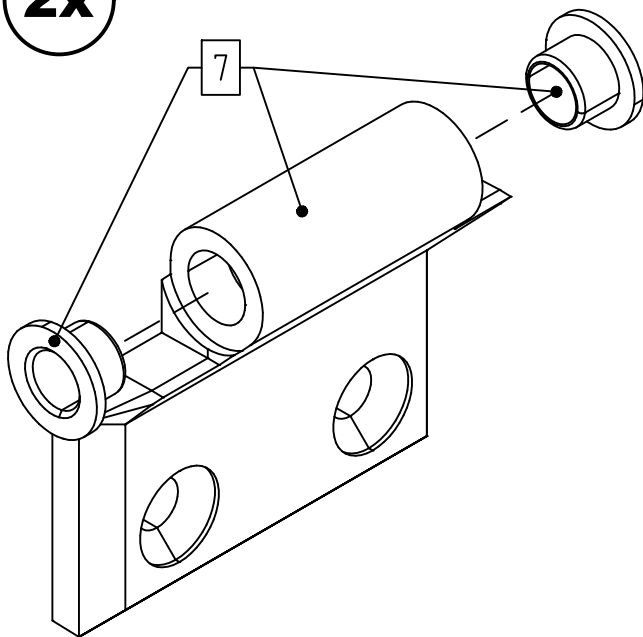



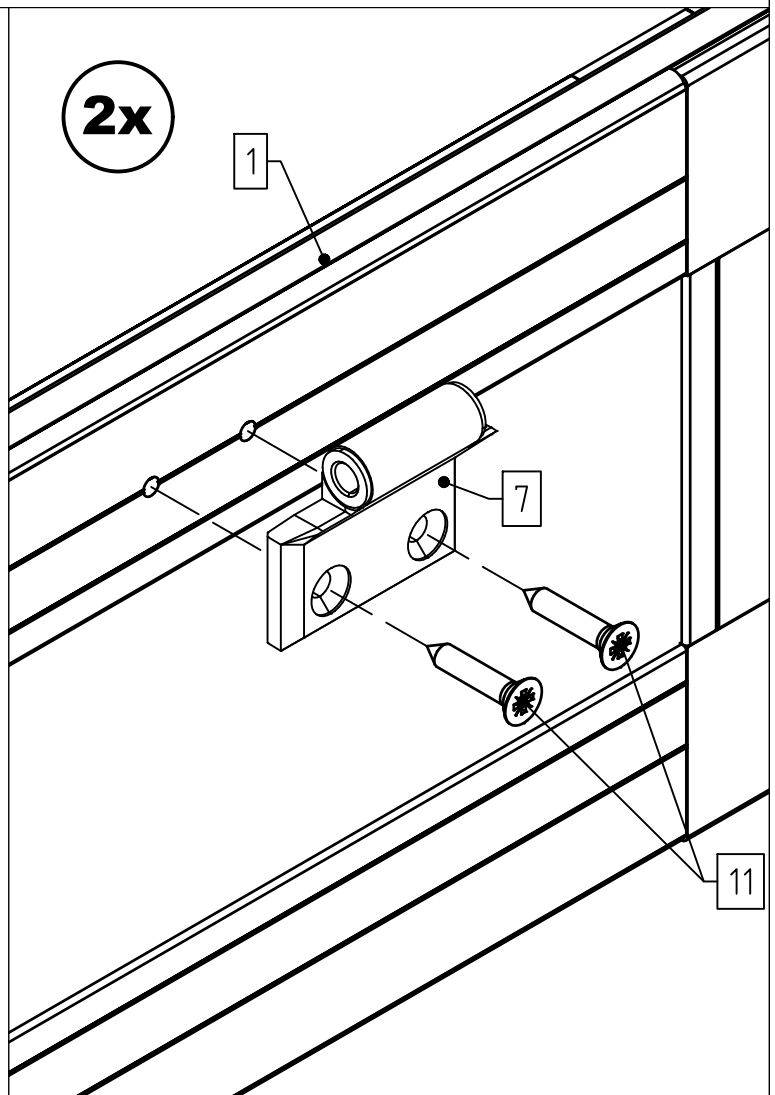

2x



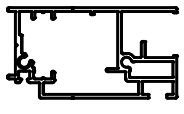
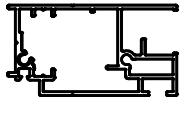
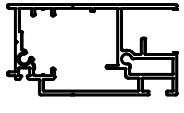
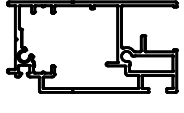
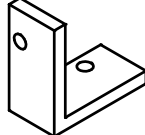
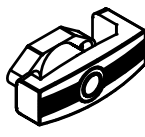
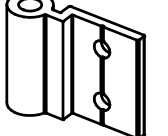

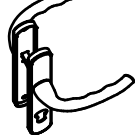
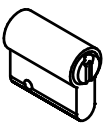



STÜCKLISTE

Tür oben Linea I

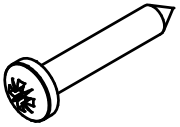
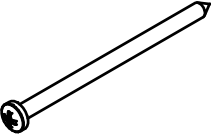
Pos.	Abbildung	Art.-Nr.	Bezeichnung	Anzahl	Bemerkung
1		P059-07-01-00-00-1	Türprofil (unten mit Entwässerungsbohrung)	1	748 mm
2		P059-01-01-00-00-1	Türprofil (oben)	1	748 mm
3		P059-04-01-00-00-1	Türprofil (Handhabe)	1	1018 mm
4		P059-05-01-00-00-1	Türprofil (Scharnier)	1	1018 mm
5		9999000065	Verbindungswinkel	4	
6		9999000023	Vorreiber	1	
7		9999000716	Scharnier	4	30 mm
8		9999000523	Schlosskasten 30mm	1	
9		9999000556	Drückergarnitur Tôkyô	1	
10		9999000522	Profilzylinder	1	
11		9999001568	Verglasungsklotz 30x15x4mm (aus Kömacell)	2	
12		9999000637	Gegenstück	1	

STÜCKLISTE

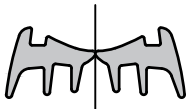
Tür oben Linea I

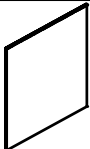
Pos.	Abbildung	Art.-Nr.	Bezeichnung	Anzahl	Bemerkung
13		9999000596	Linsenkopfschraube 4,2 x 25	4	DIN 7981
14		9999000662	Linsenkopfschraube 4,2 x 70	4	DIN 7981
15		9999000152	Senkkopfschraube 3,5 x 22	2	DIN 7982
16		9999000204	Senkkopfschraube 4,2 x 13	2	DIN 7982
17		9999000144	Linsenkopfschraube 4,2 x 13	8	DIN 7981
18		9999002532	Bohrschraube Linsenkopf 3,9 x 13	1	DIN 7504
19		9999000120	Keildichtung 6–8mm	2,0 lfdm. (Doppelstrang)	Dichtung mittig auseinanderziehen
20		99990000032	Y-Dichtung (Horizontaldichtung)	4,0 lfdm.	
21			PC-Hohlkammerplatte 924 x 654mm	1	
22					
23					
24					

A

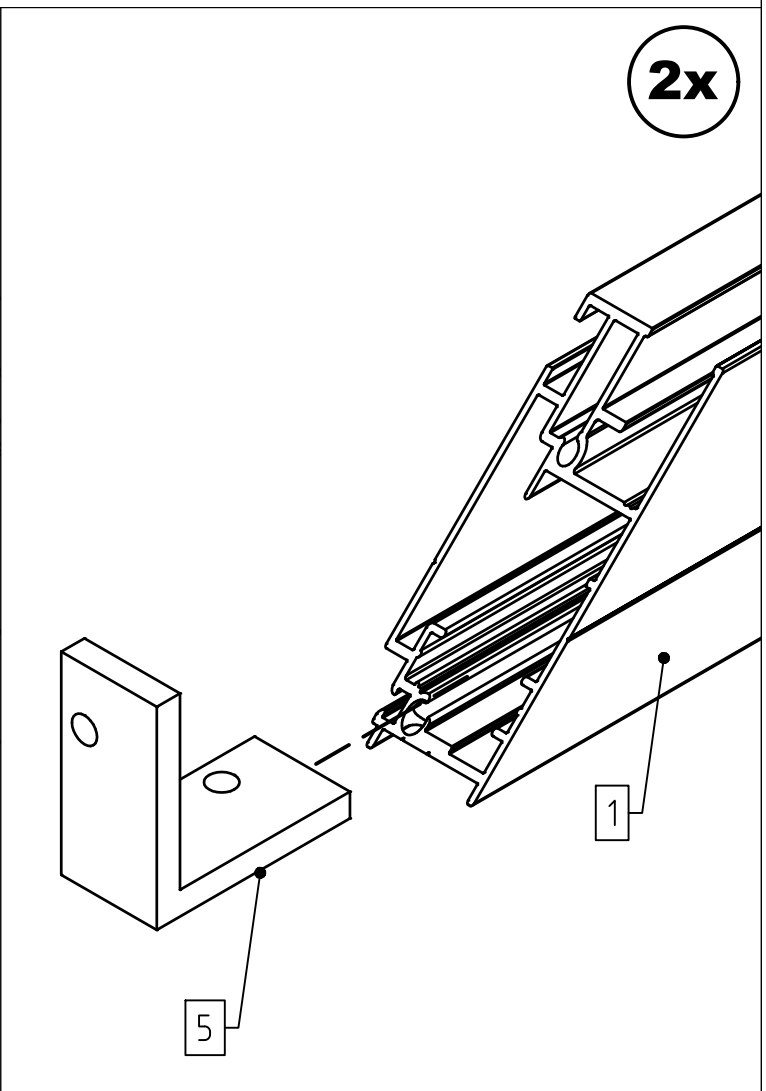
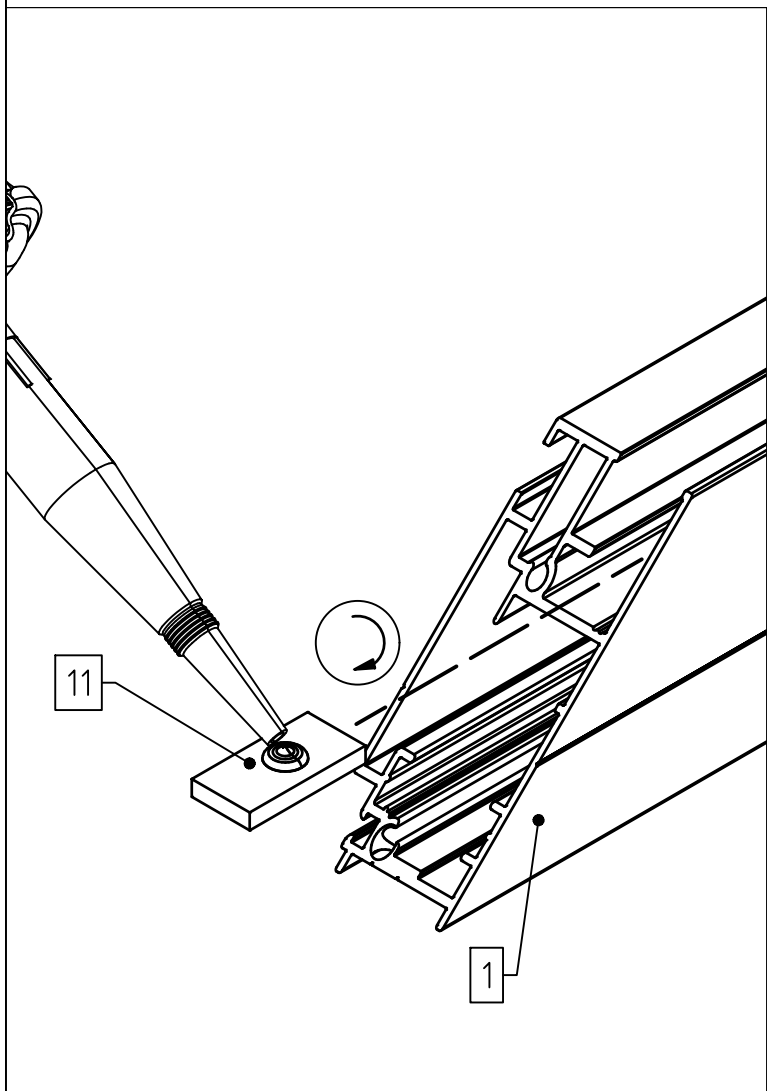
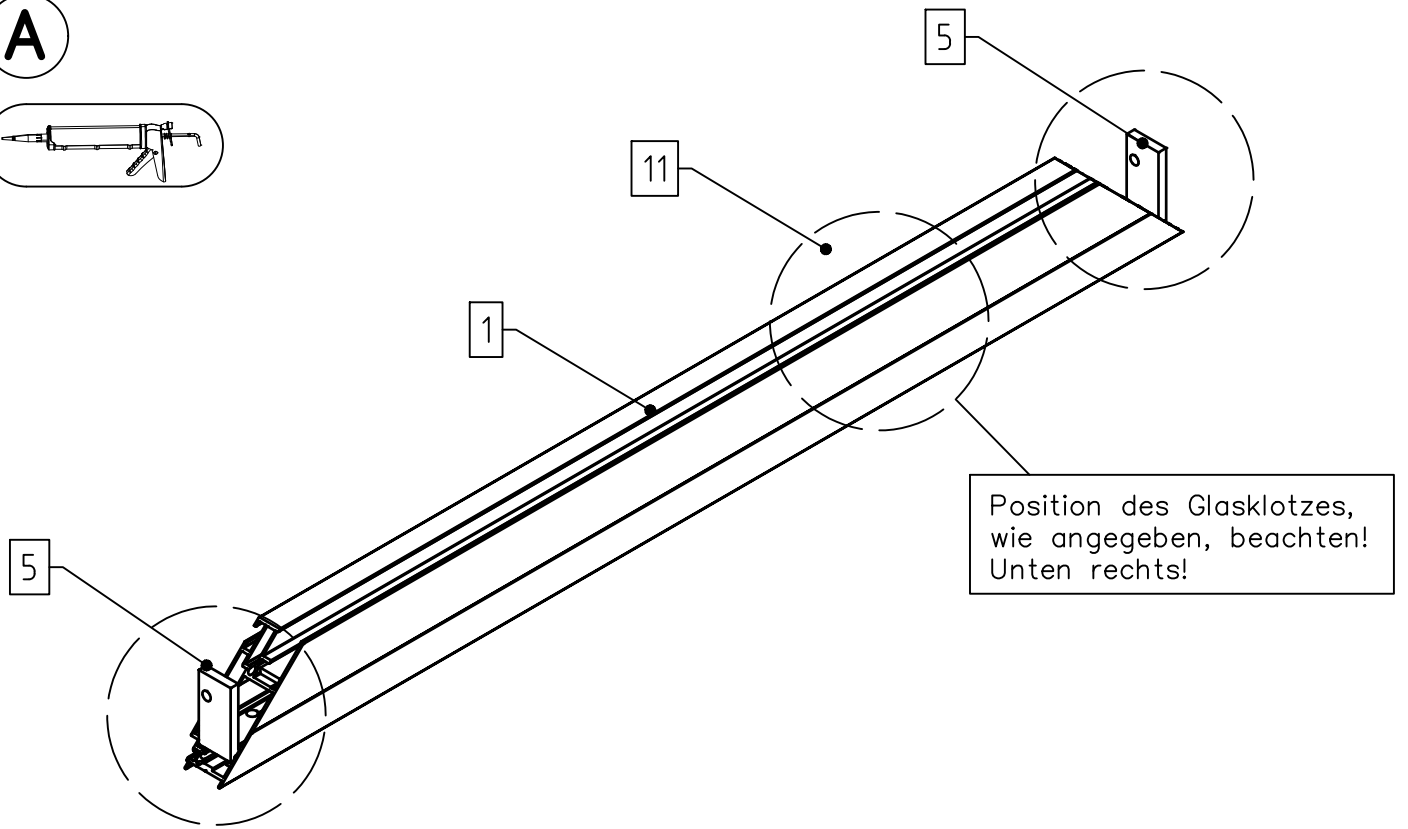
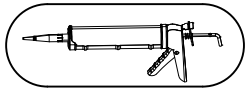

2x

A

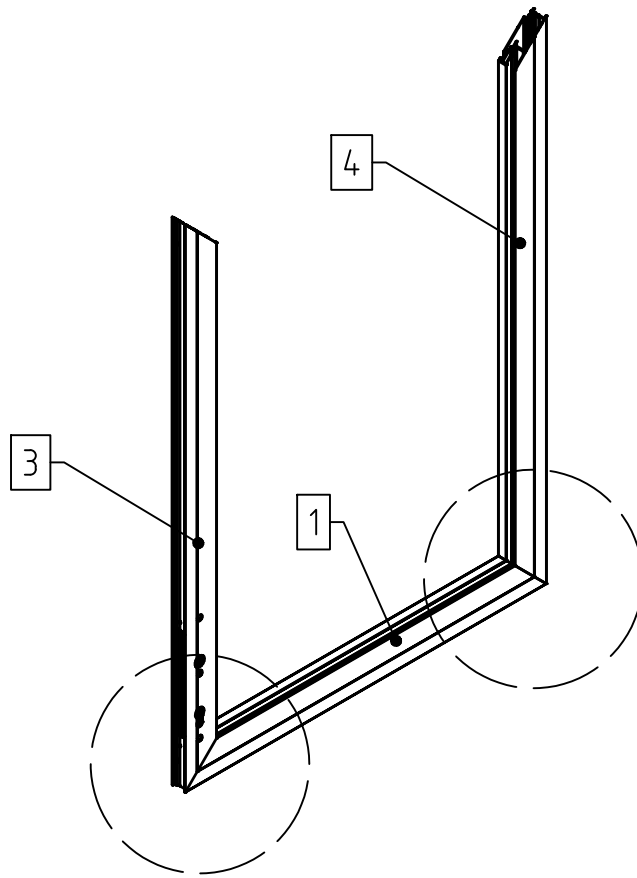

2x

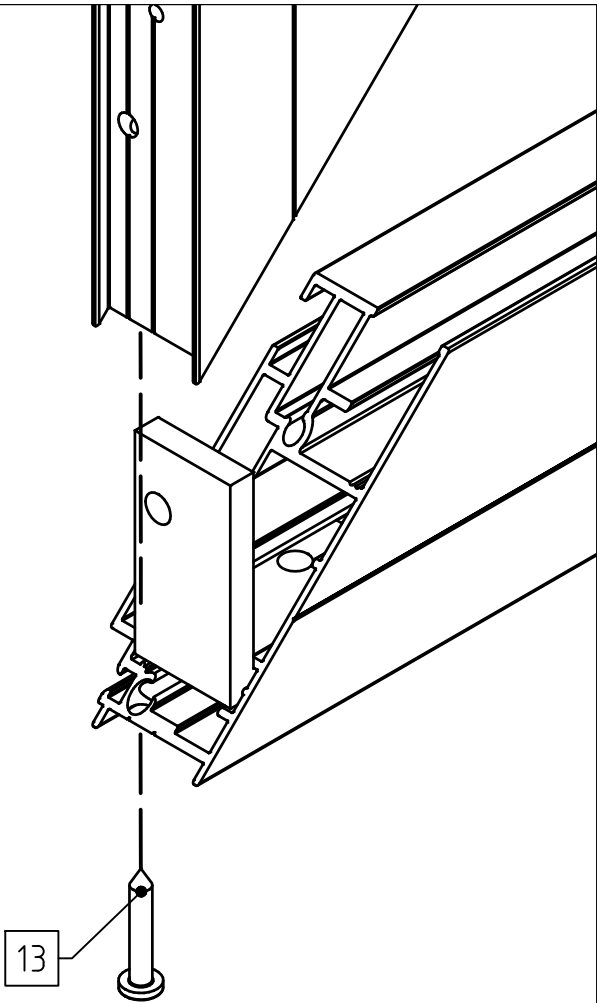

2x

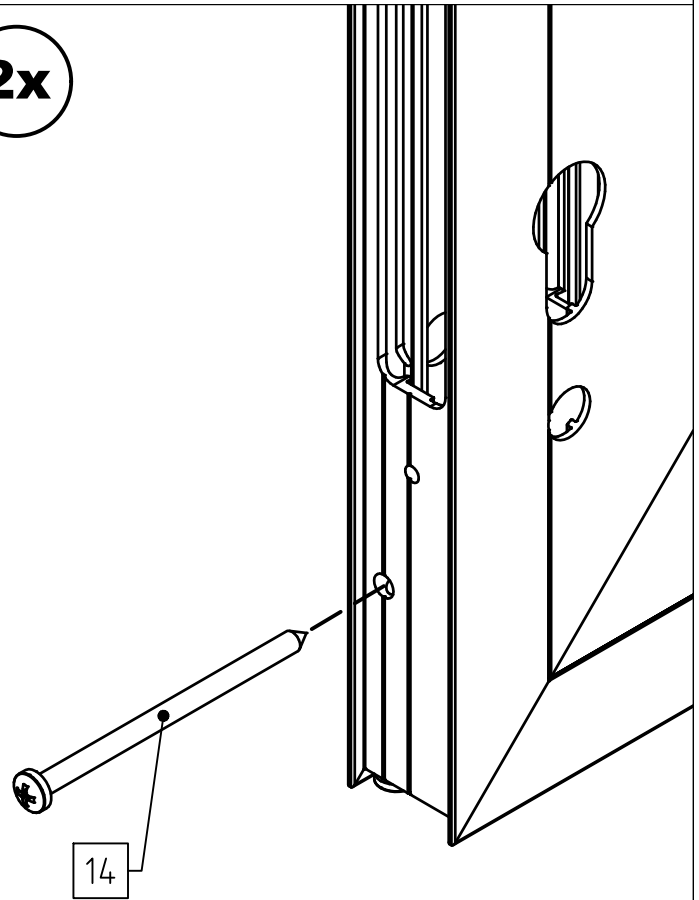

A

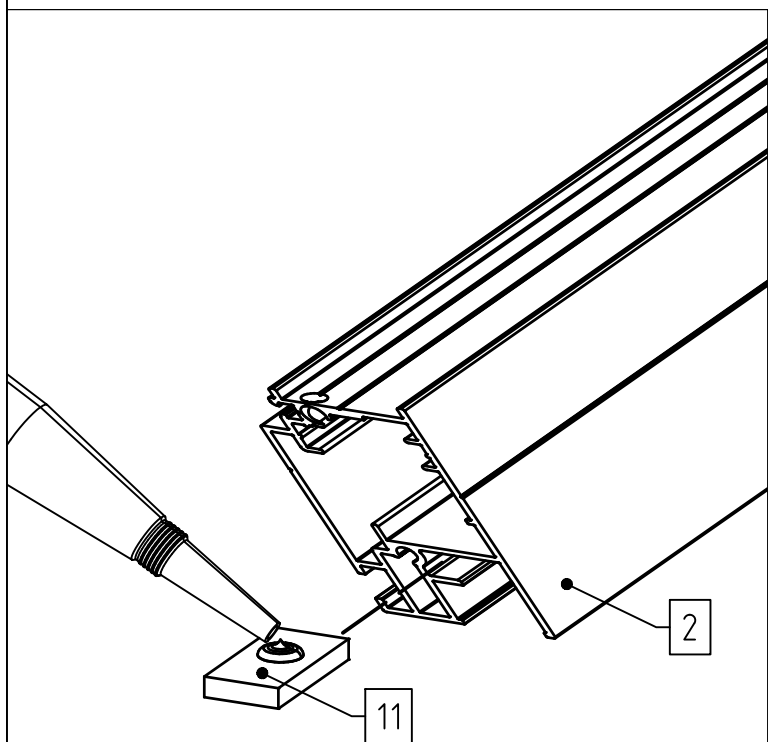
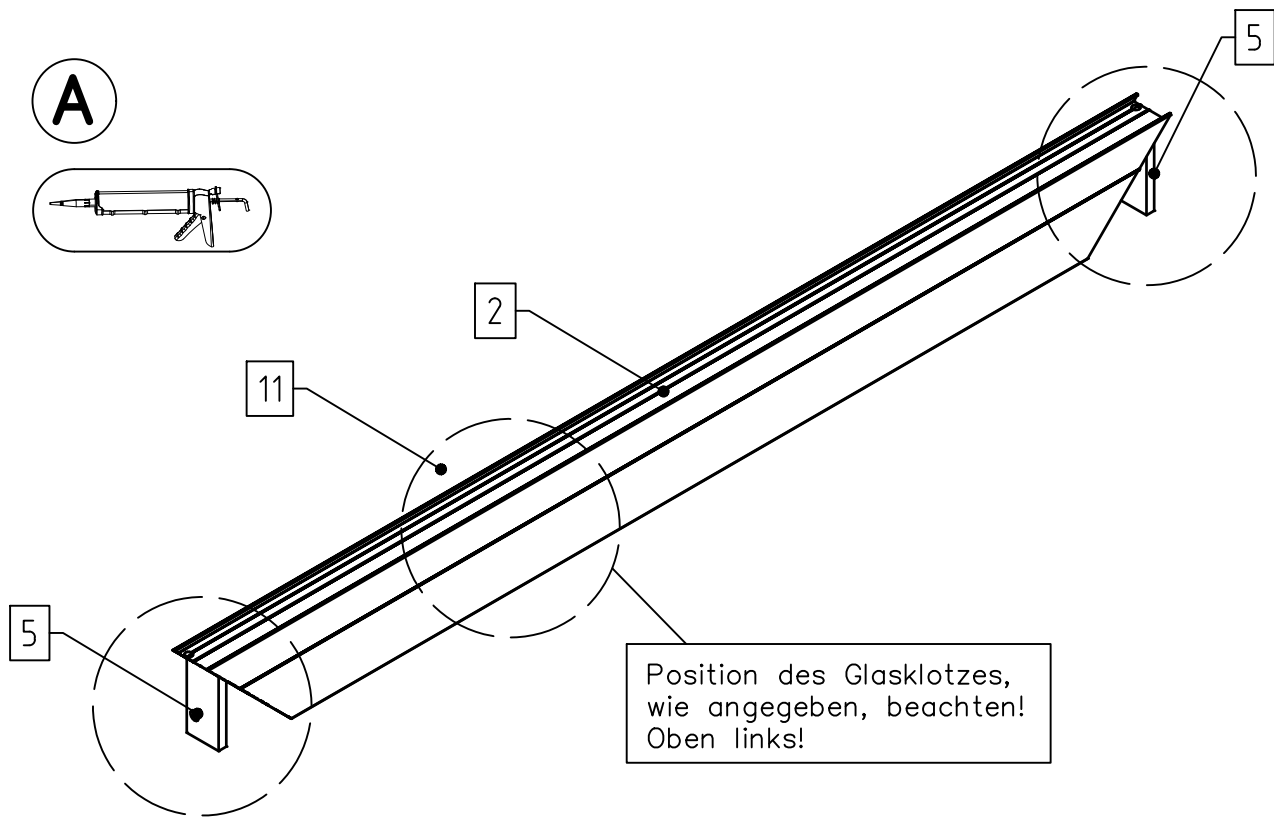
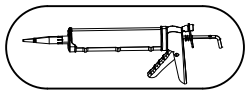

2x

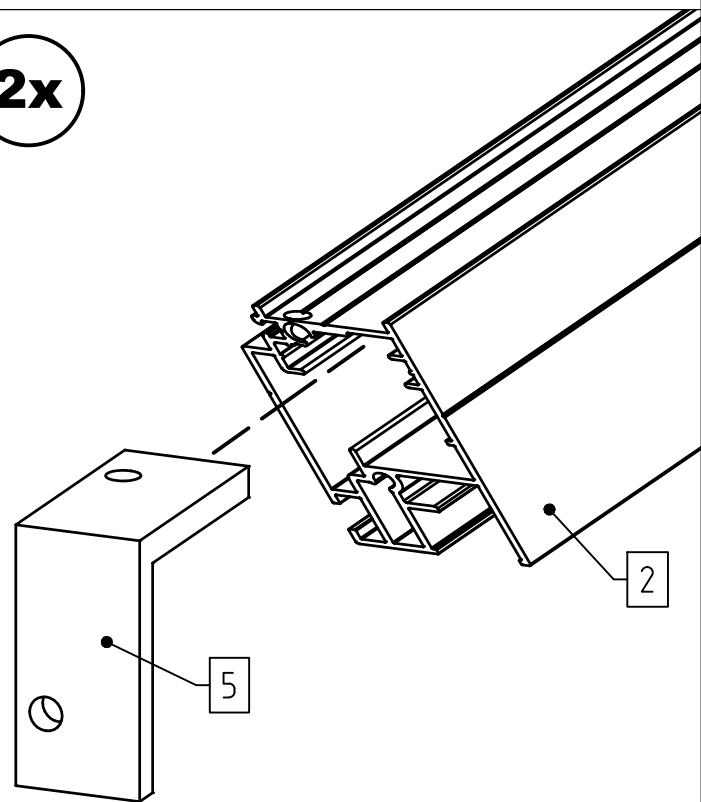

A

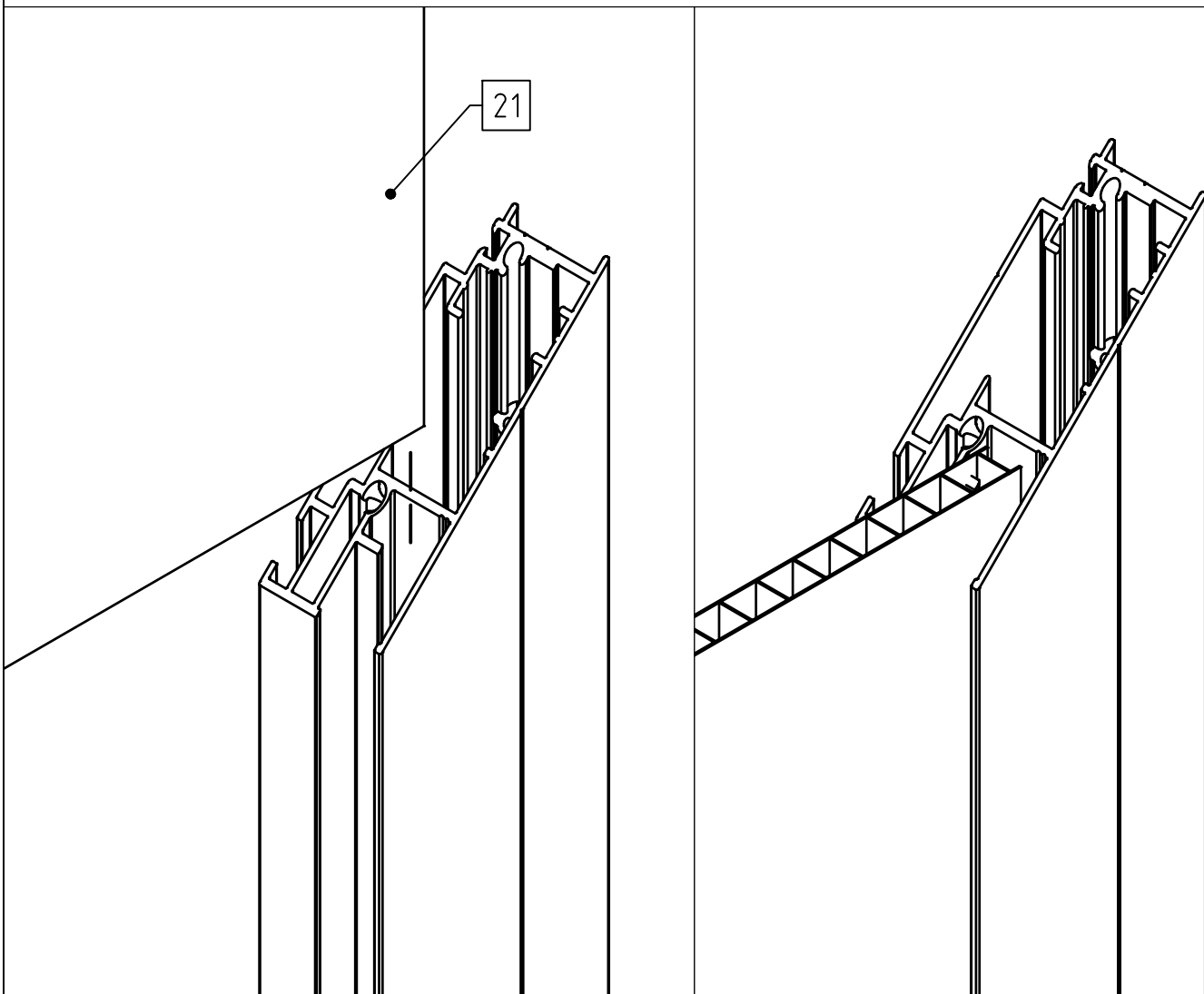
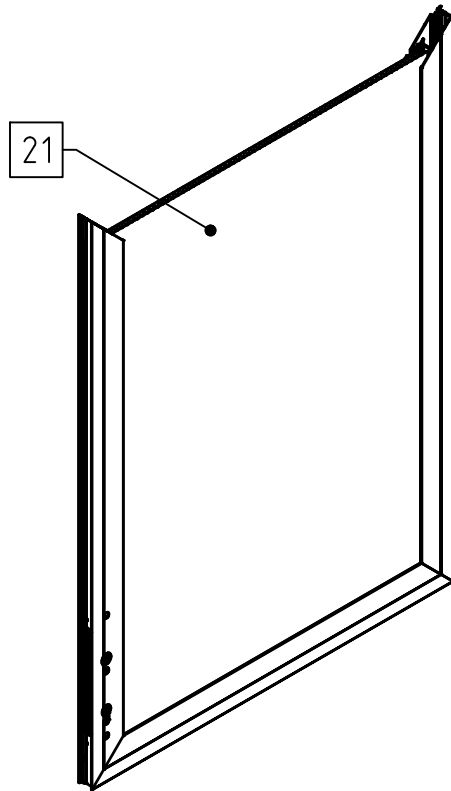

A

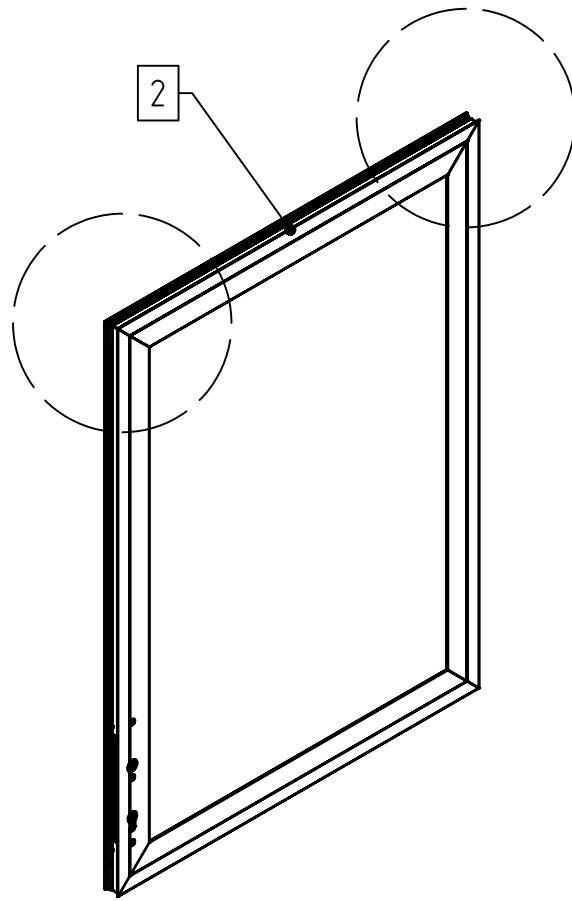

2x

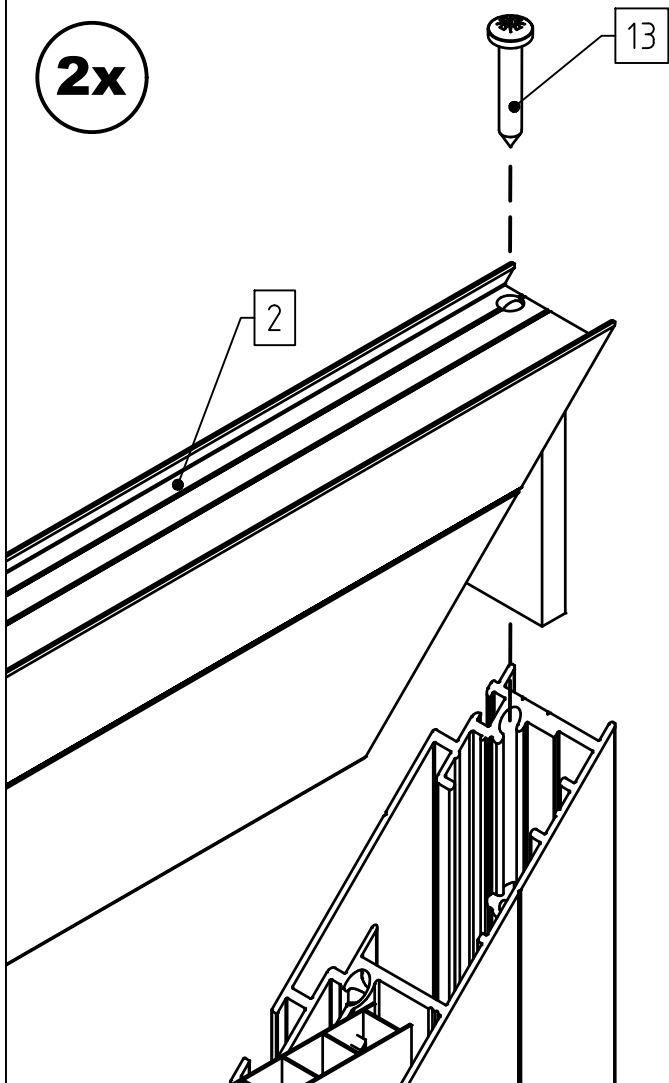

2x

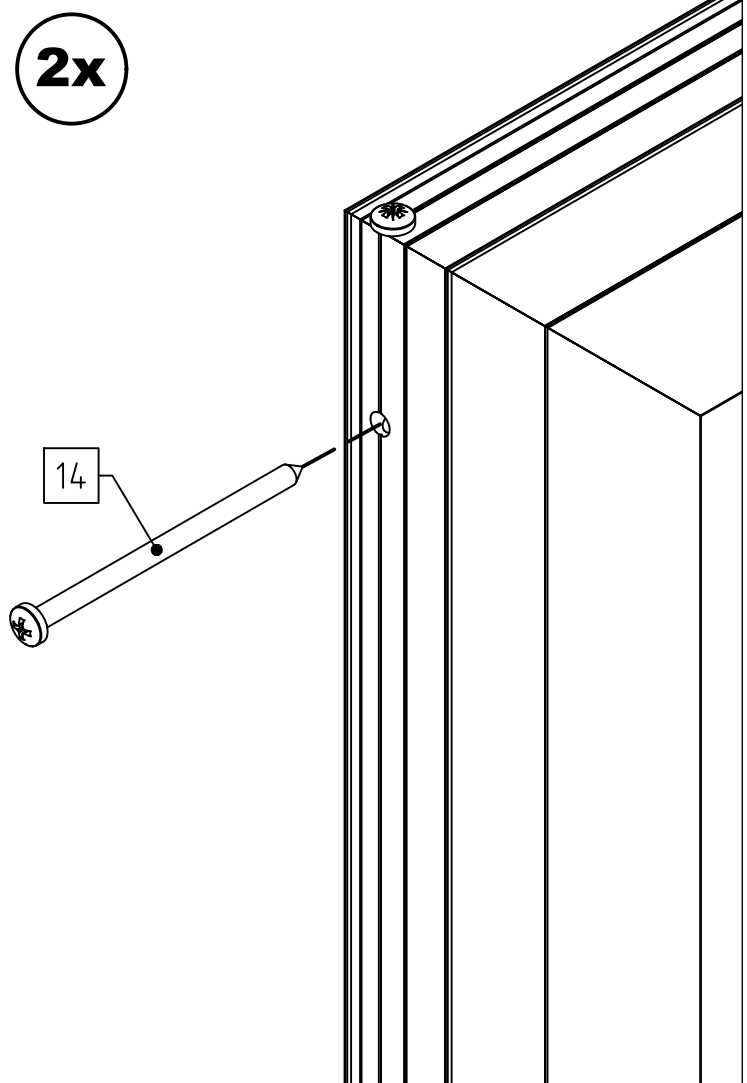

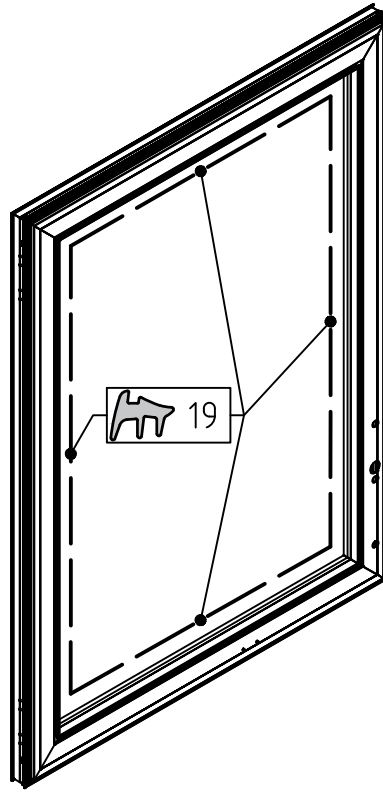

2x

19

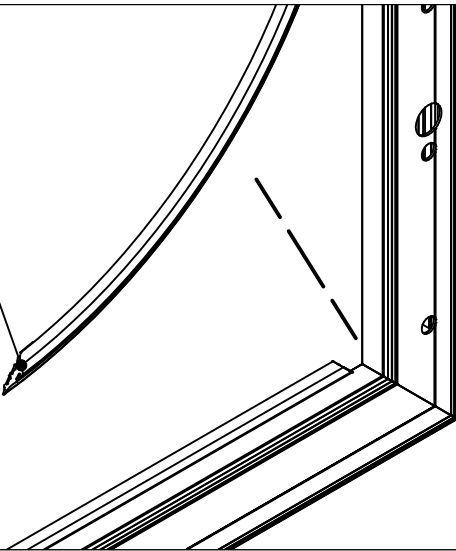

19

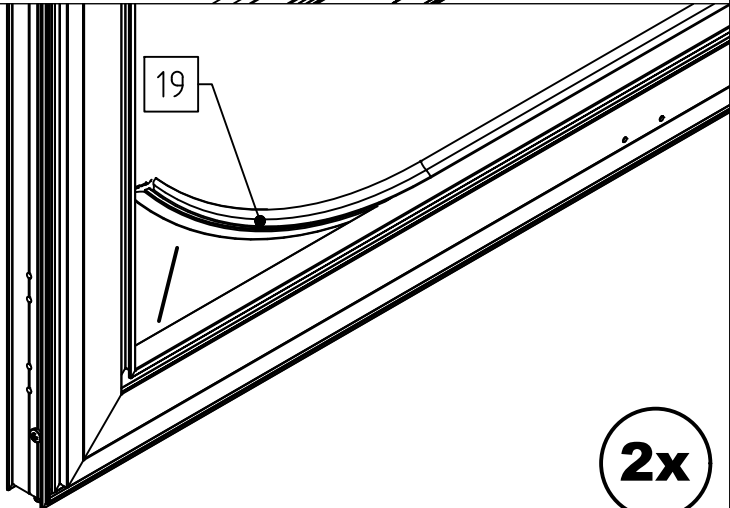

2x

VD

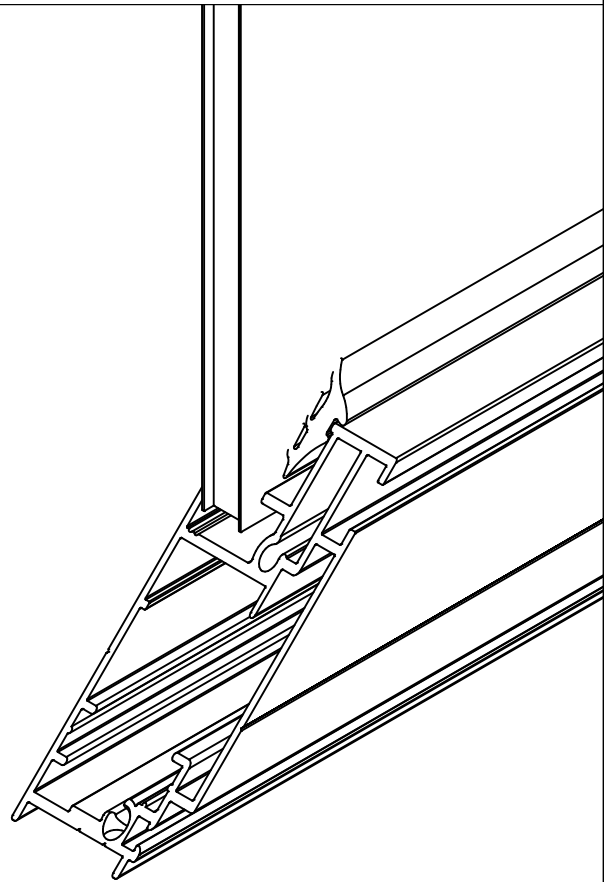

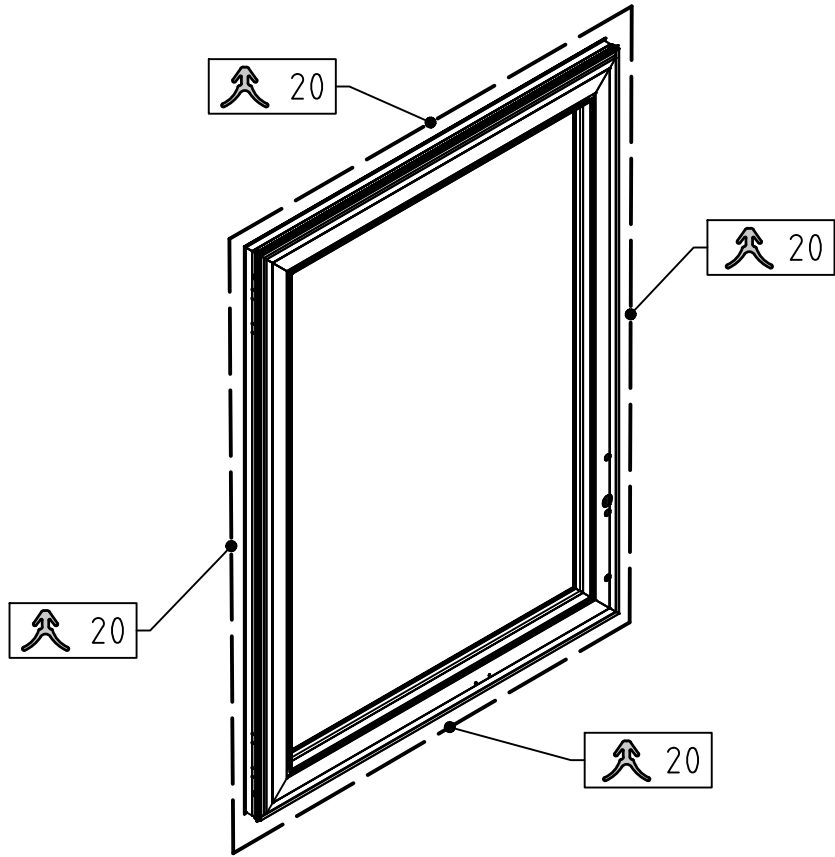

2x

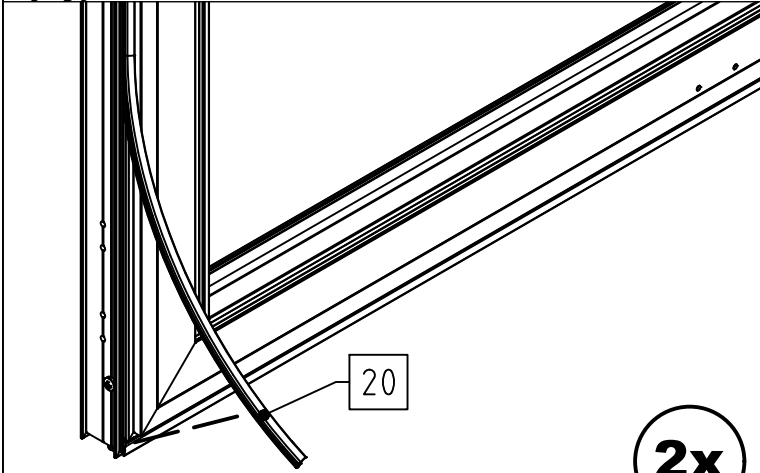
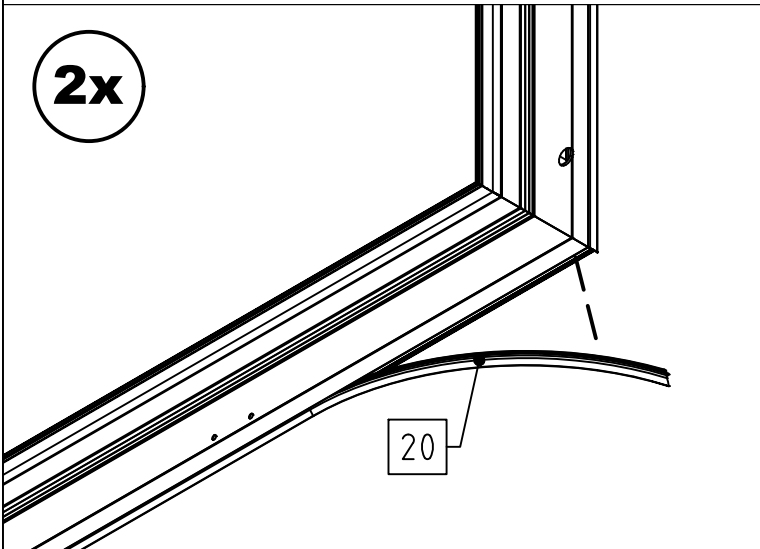

2x

VD

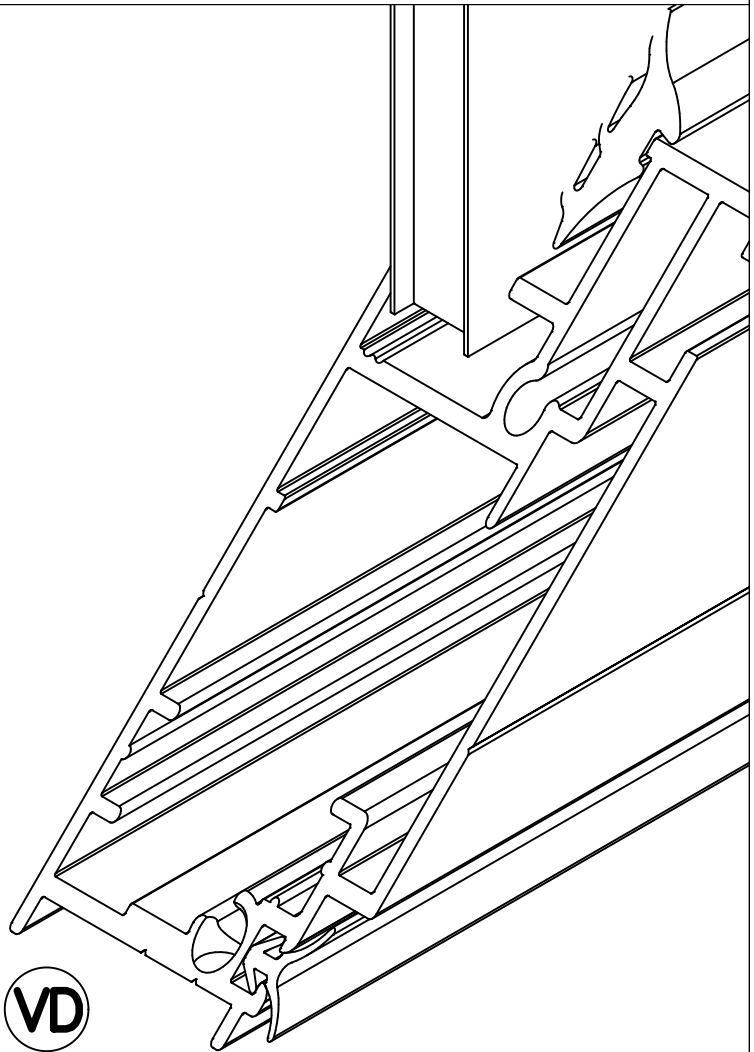



A

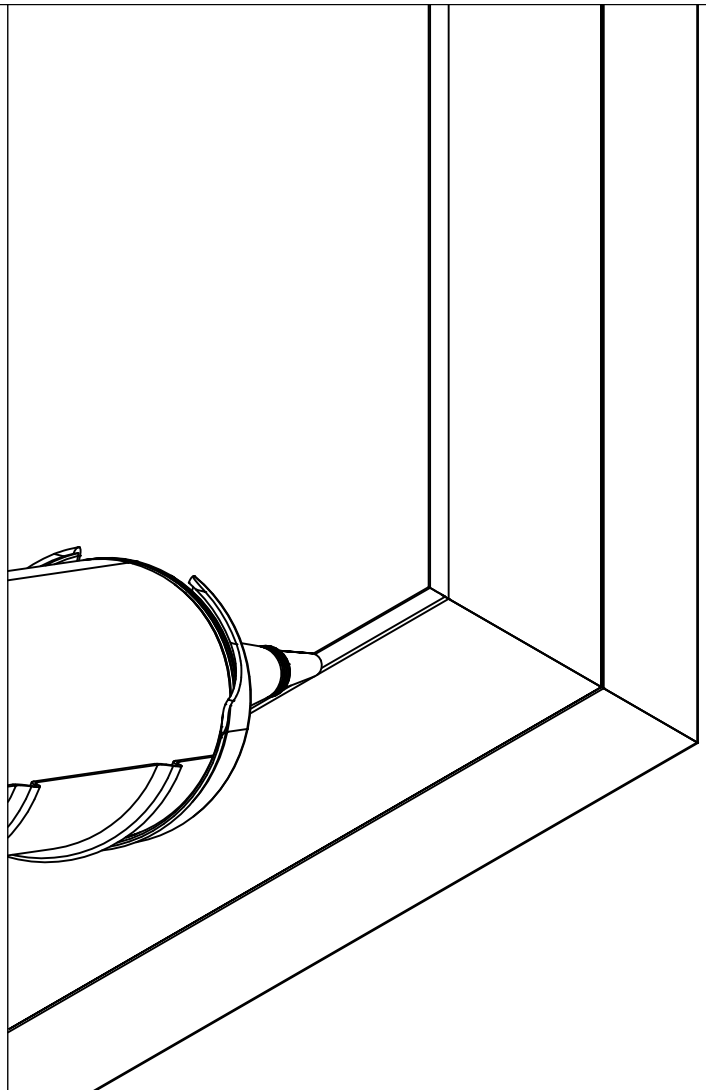
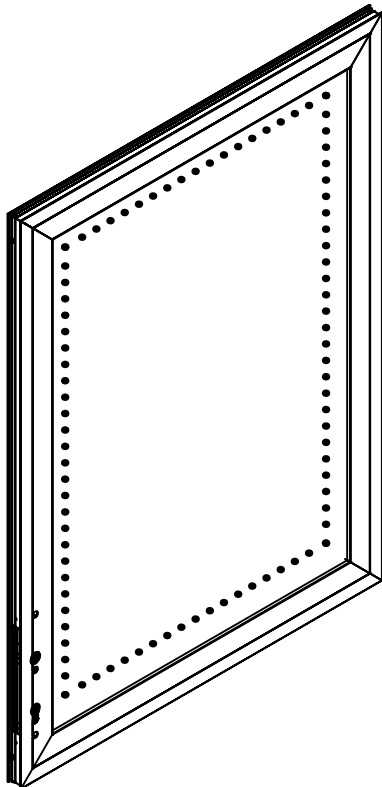
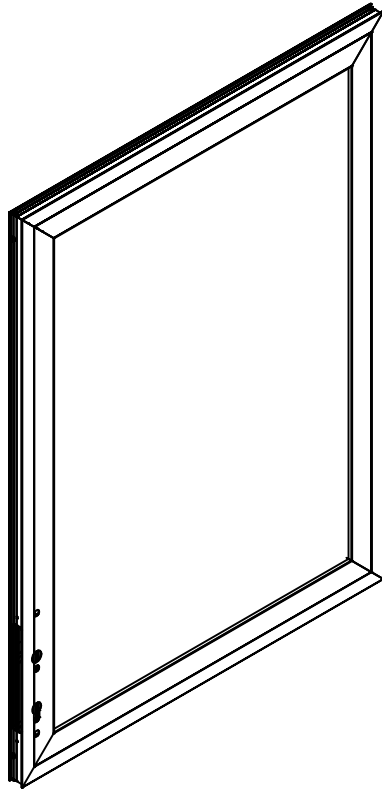
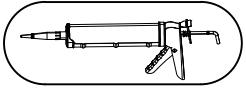

A

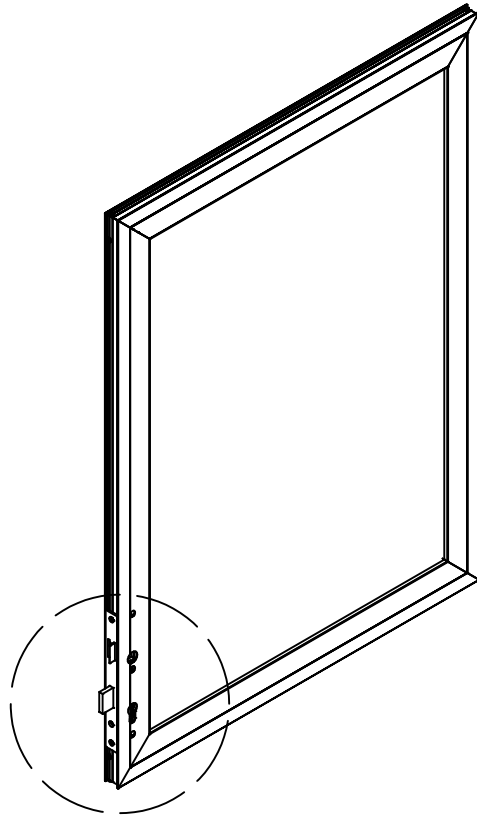

A

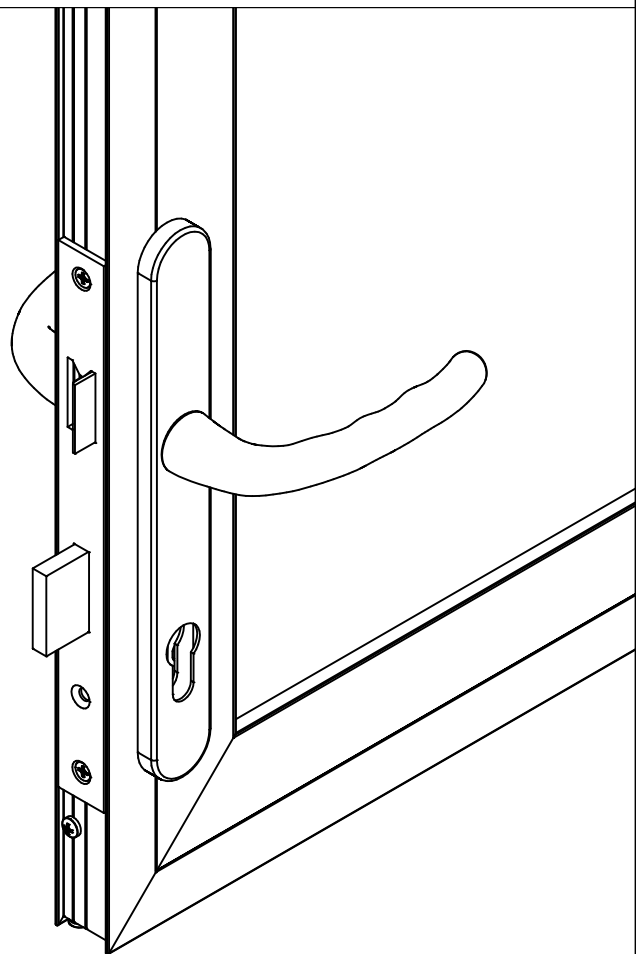
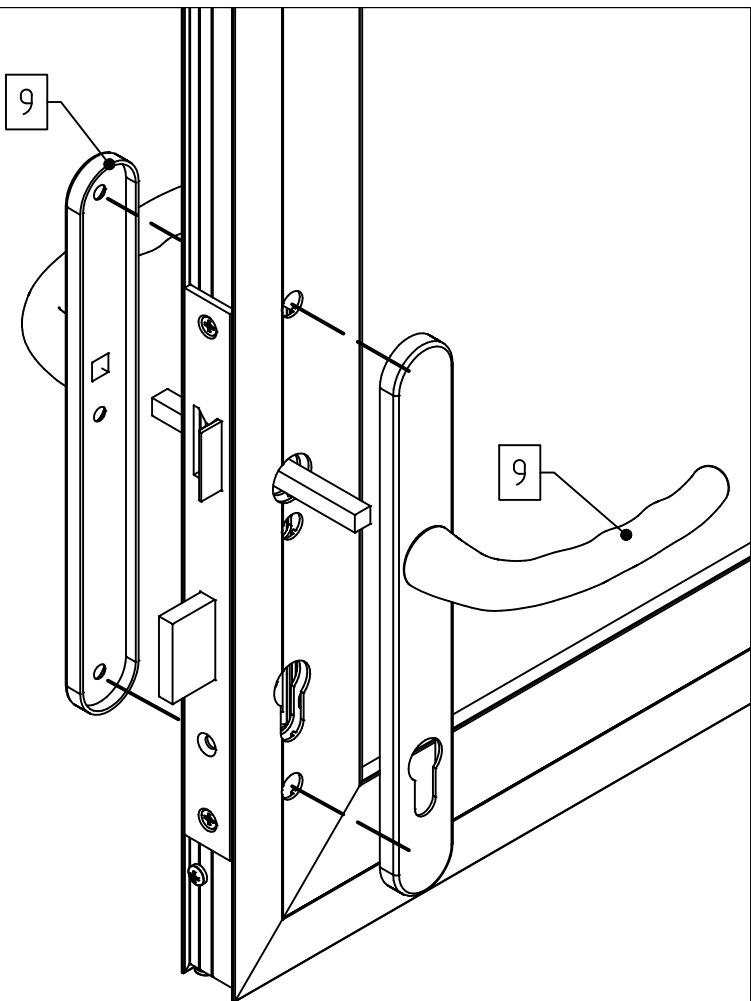
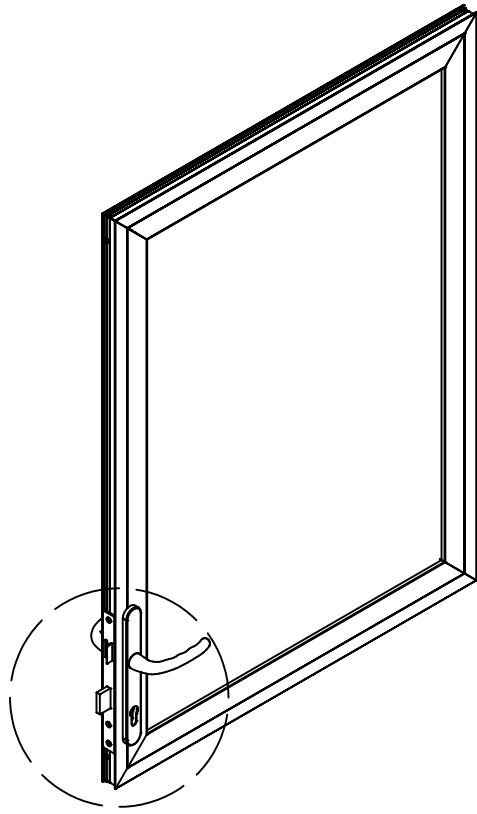

A

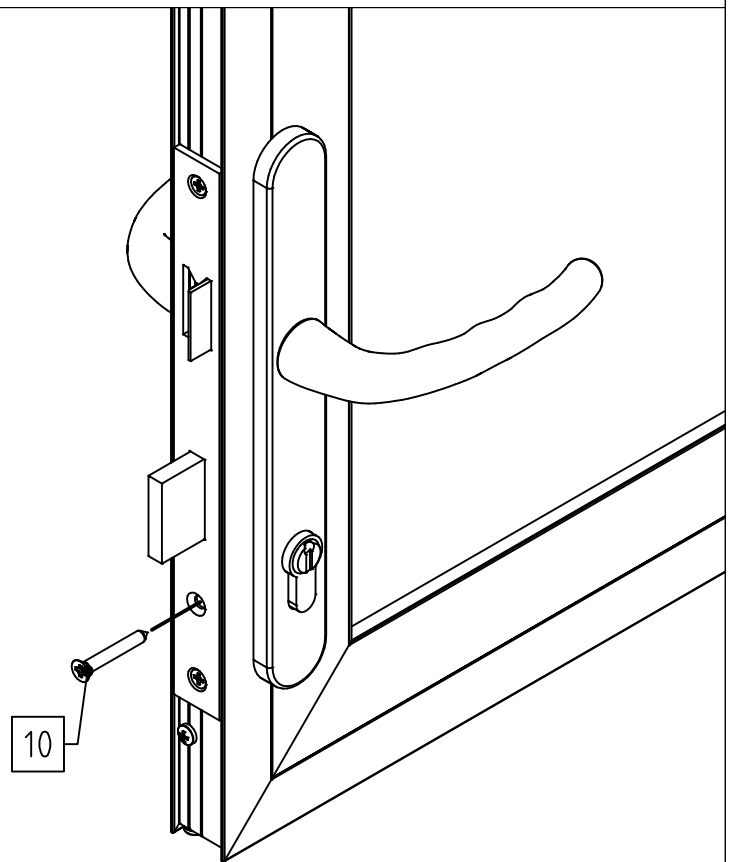
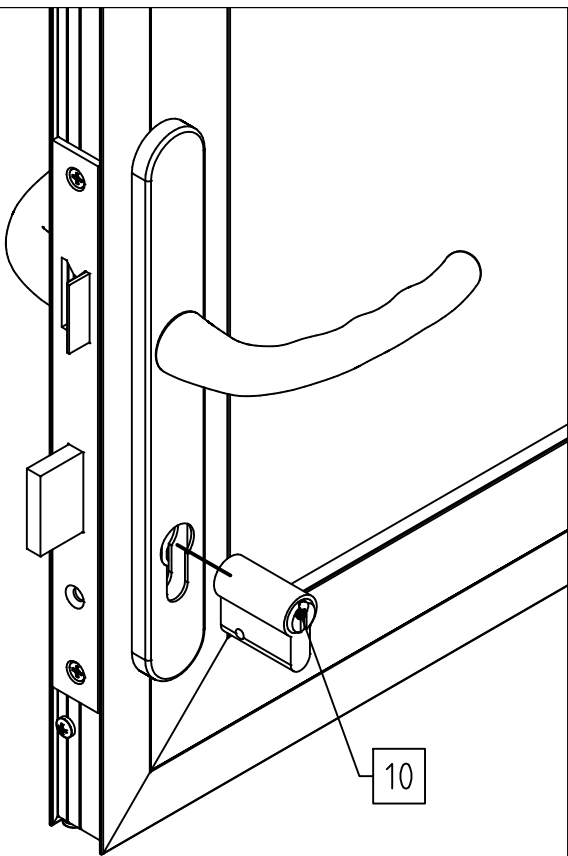
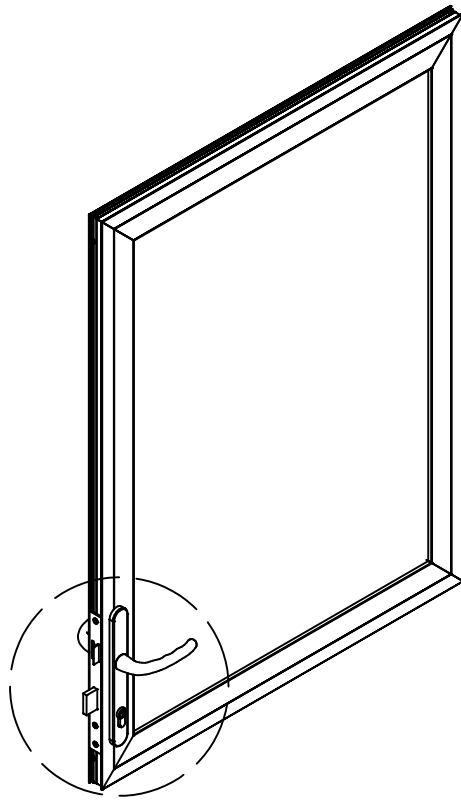

L

1

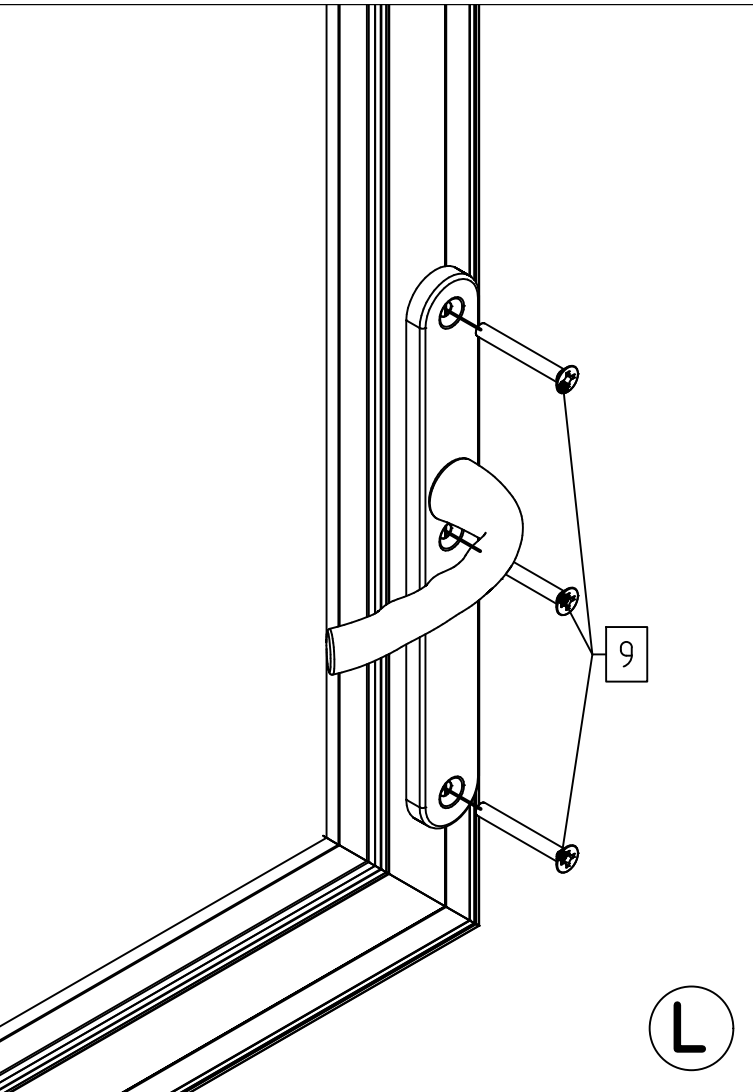
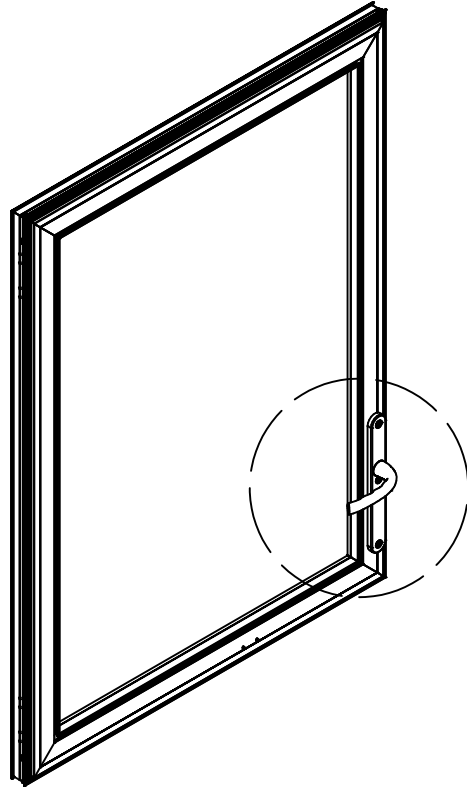

L

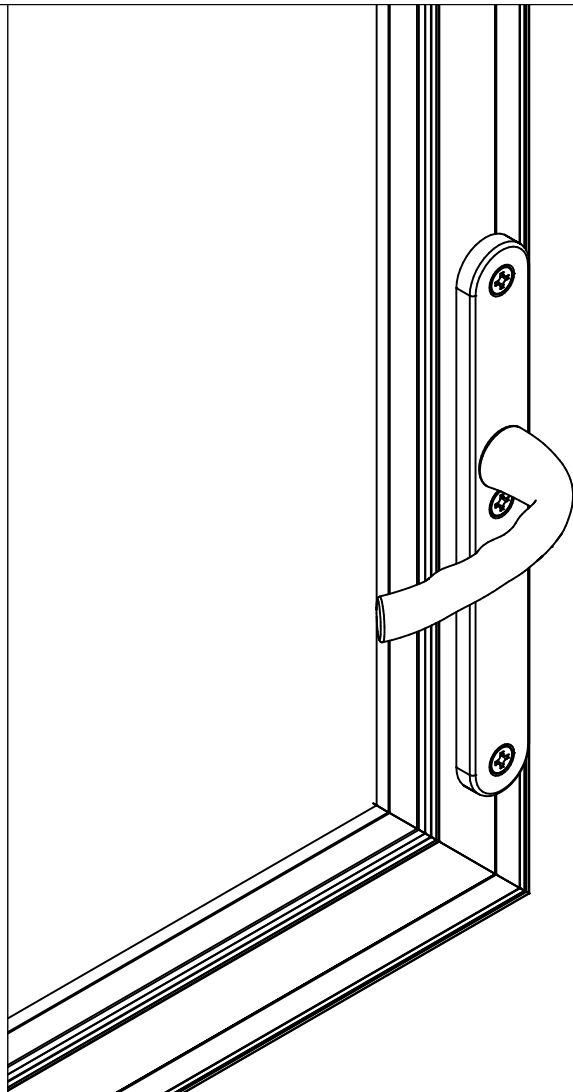

1

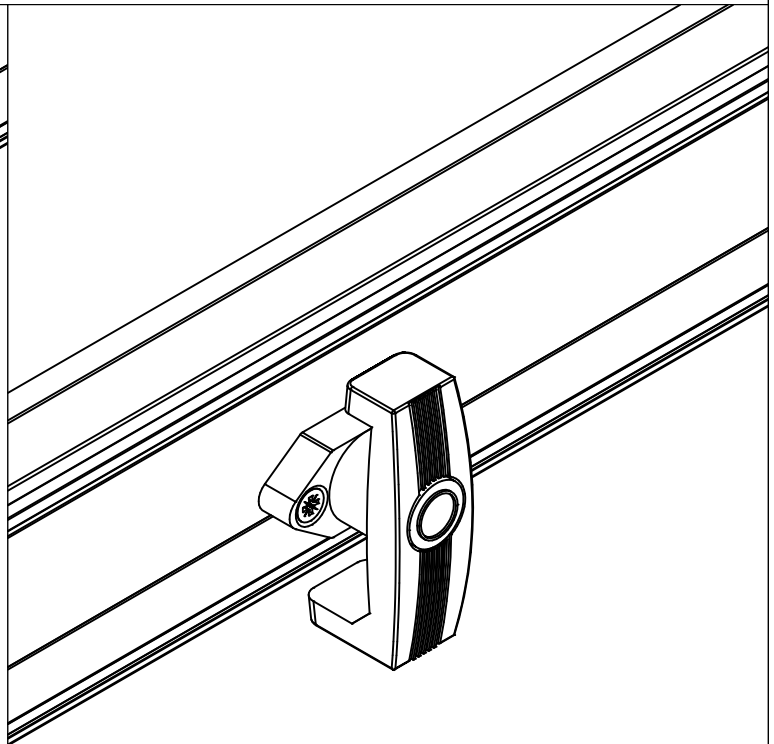
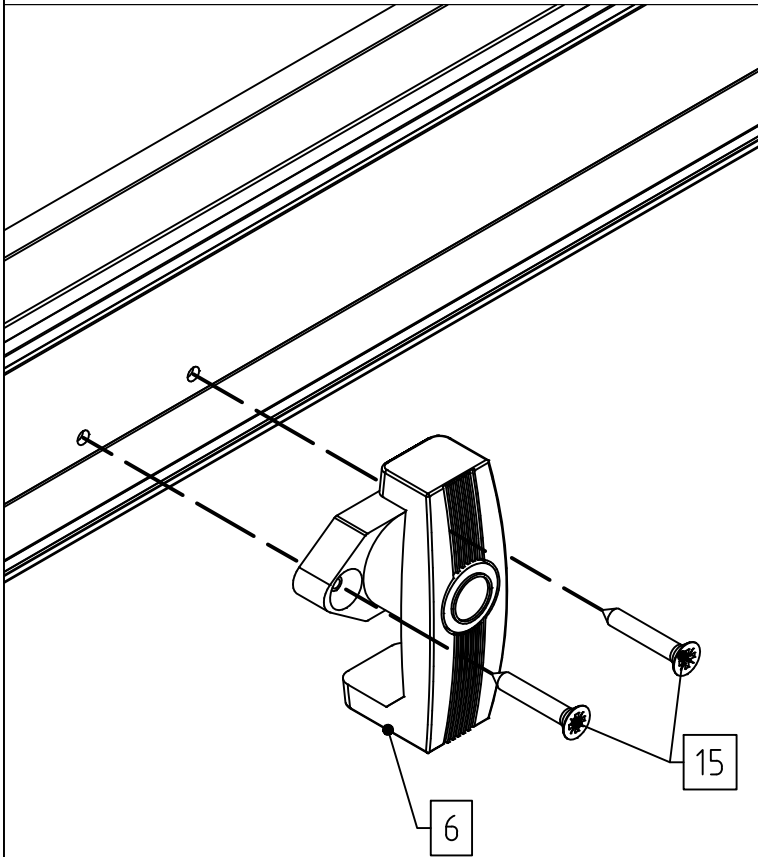
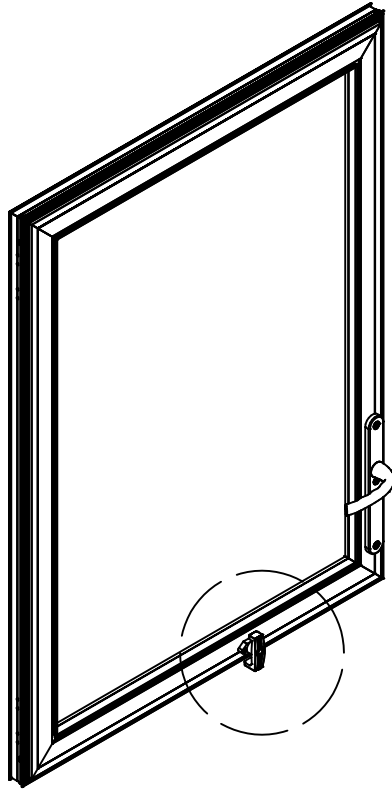

1

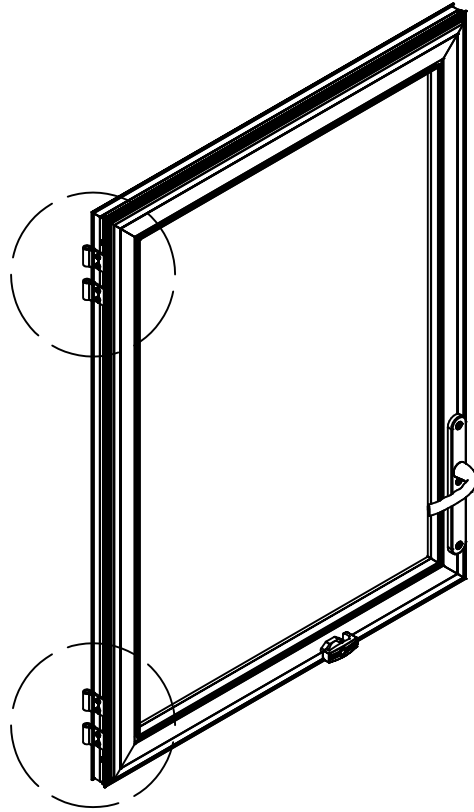

2x

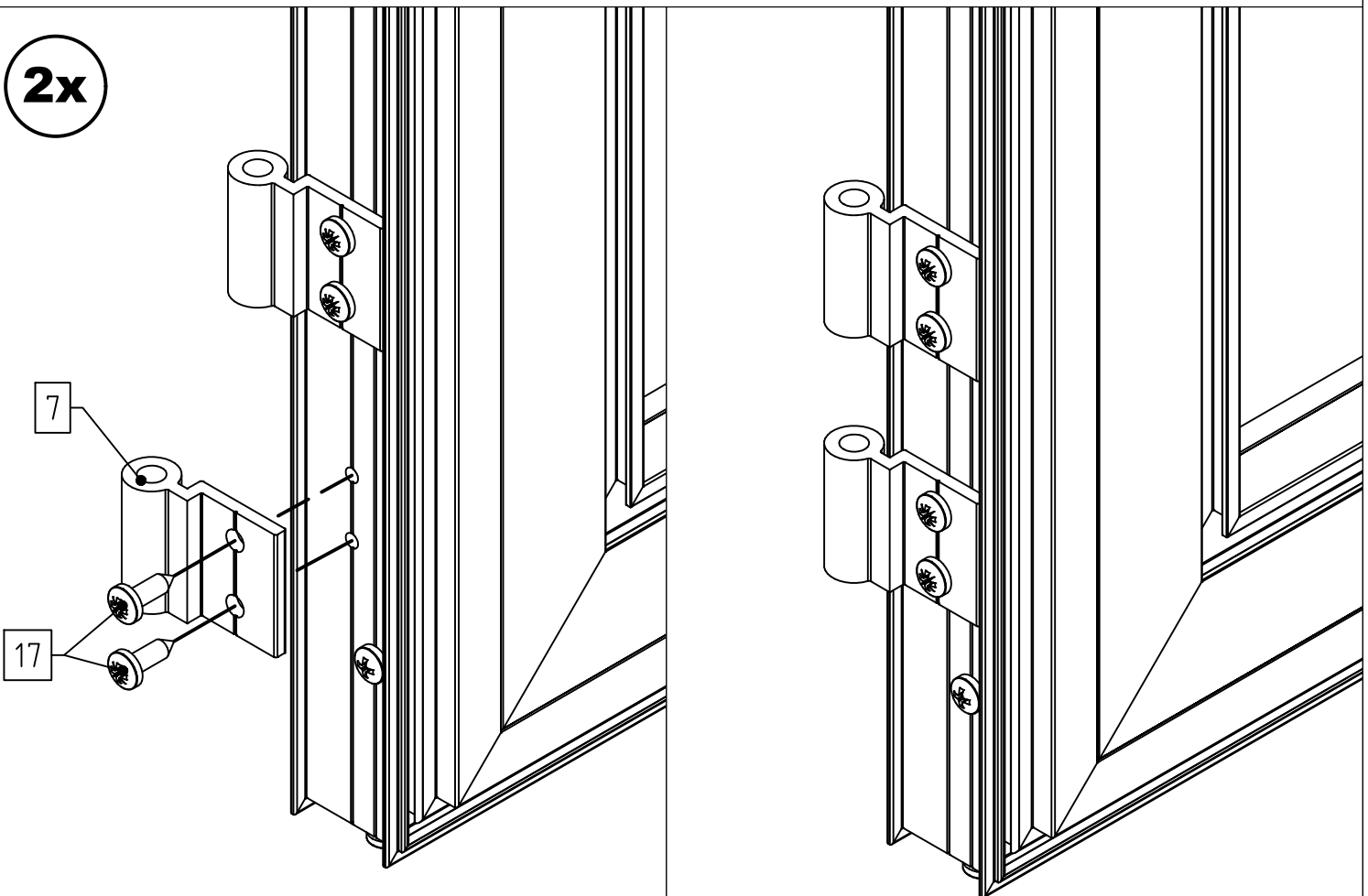



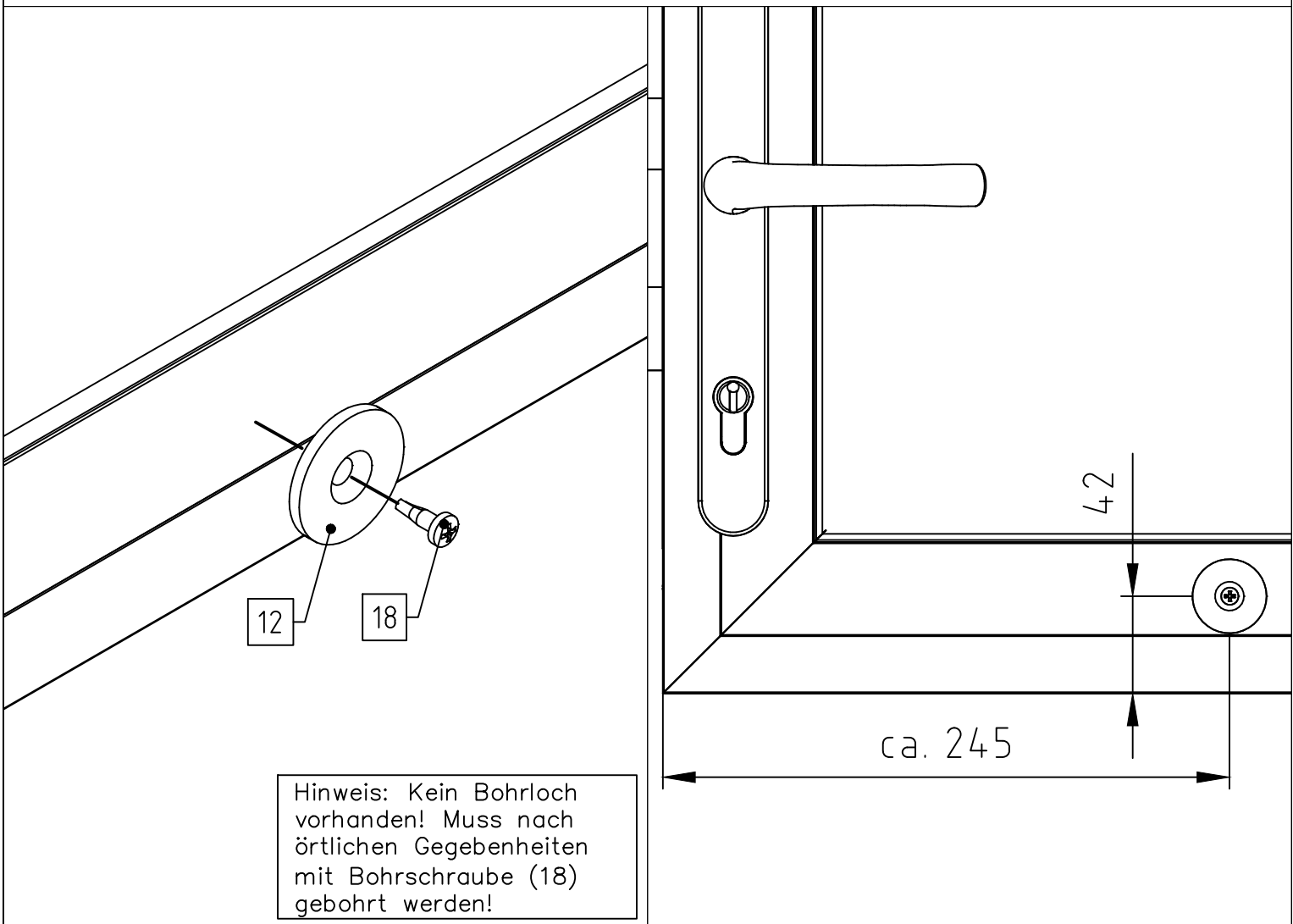
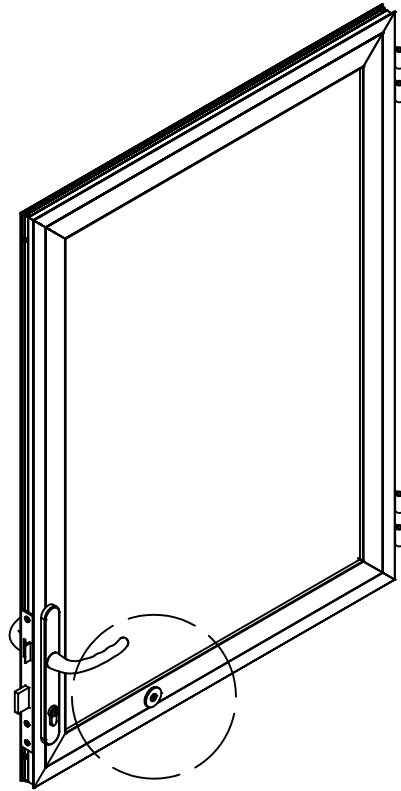

A



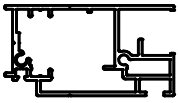
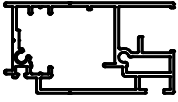
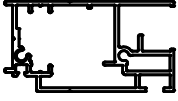
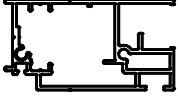
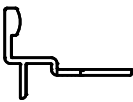

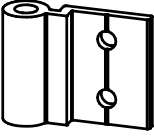
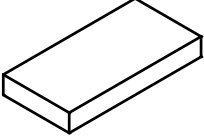
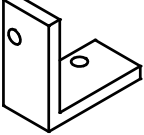
STÜCKLISTE

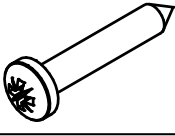
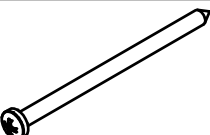
Tür unten Linea I

Pos.	Abbildung	Art.-Nr.	Bezeichnung	Anzahl	Bemerkung
1		P059-10-01-00-00-1	Türprofil (unten mit Entwässerungsbohrung)	1	748 mm
2		P059-06-01-00-00-1	Türprofil (oben)	1	748 mm
3		P059-02-01-00-00-1	Türprofil (Vorreiber)	1	790 mm
4		P059-03-01-00-00-1	Türprofil (Scharnier)	1	790 mm
5		P061-01-01-00-00-1	Türanschlag mitte	1	742 mm
6		9999000023	Vorreiber	1	
7		9999000716	Scharnier	4	30 mm
8		9999001568	Verglasungsklotz	2	
9		9999000065	Verbindungswinkel	4	
10		9999000144	Linsenkopfschraube 4,2x13	11	DIN 7981
11		9999000596	Linsenkopfschraube 4,2x25	4	DIN 7981
12		9999000662	Linsenkopfschraube 4,2x70	4	DIN 7981

STÜCKLISTE

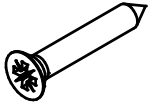
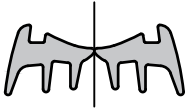
Tür unten Linea I

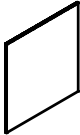
Pos.	Abbildung	Art.-Nr.	Bezeichnung	Anzahl	Bemerkung
13		9999000152	Senkkopfschraube 3,5x22	2	DIN 7982
14		9999000120	Keildichtung 6-8mm	1,7 lfdm. (Doppelstrang)	Dichtung mittig auseinanderziehen
15		9999000032	Y-Dichtung (Horizontaldichtung)	2,8 lfdm.	
16			PC-Hohlkammerplatte 654x696mm	1	
17					
18					
19					
20					
21					
22					
23					
24					

A

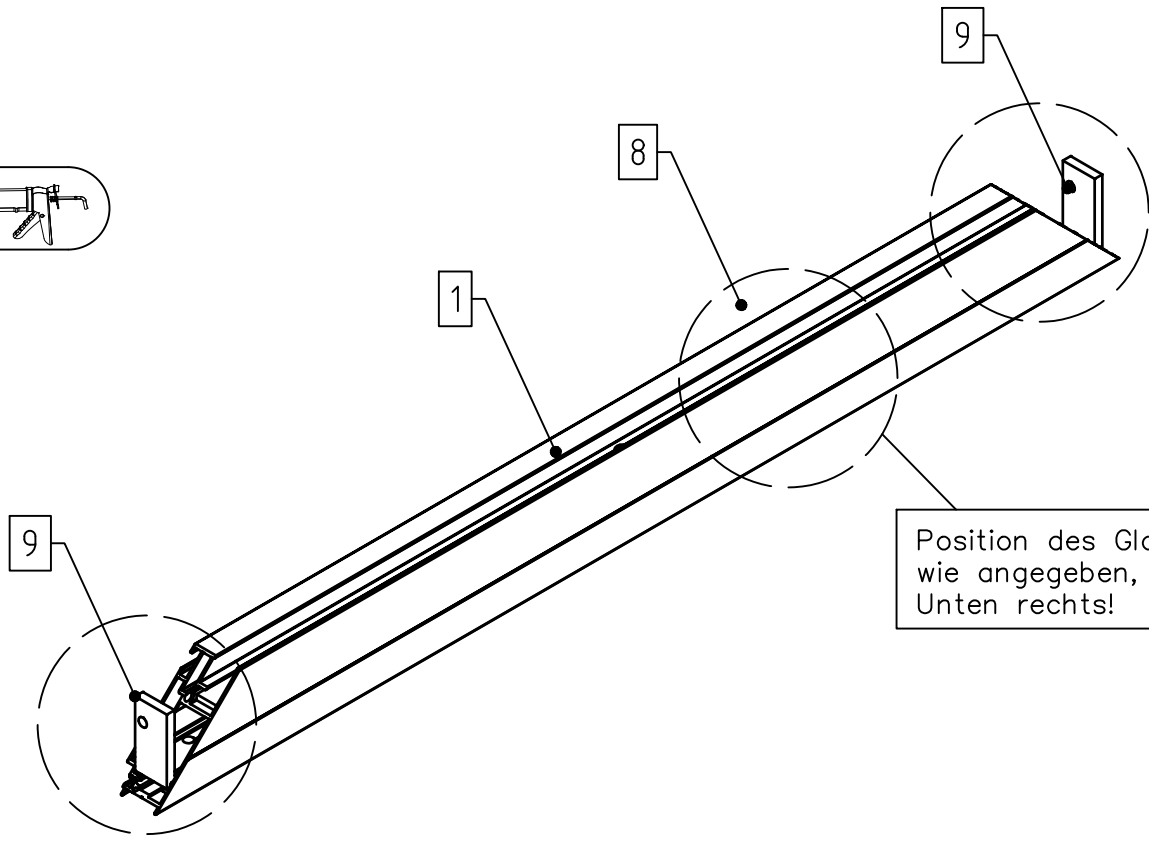
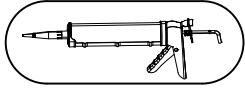

Position des Glasklotzes,
wie angegeben, beachten!
Unten rechts!

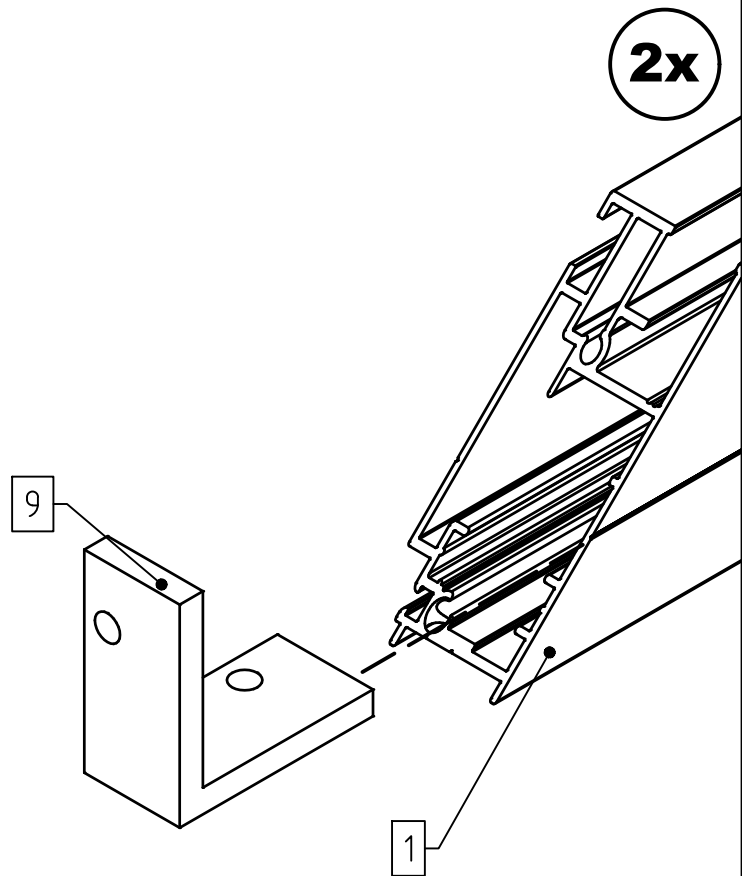
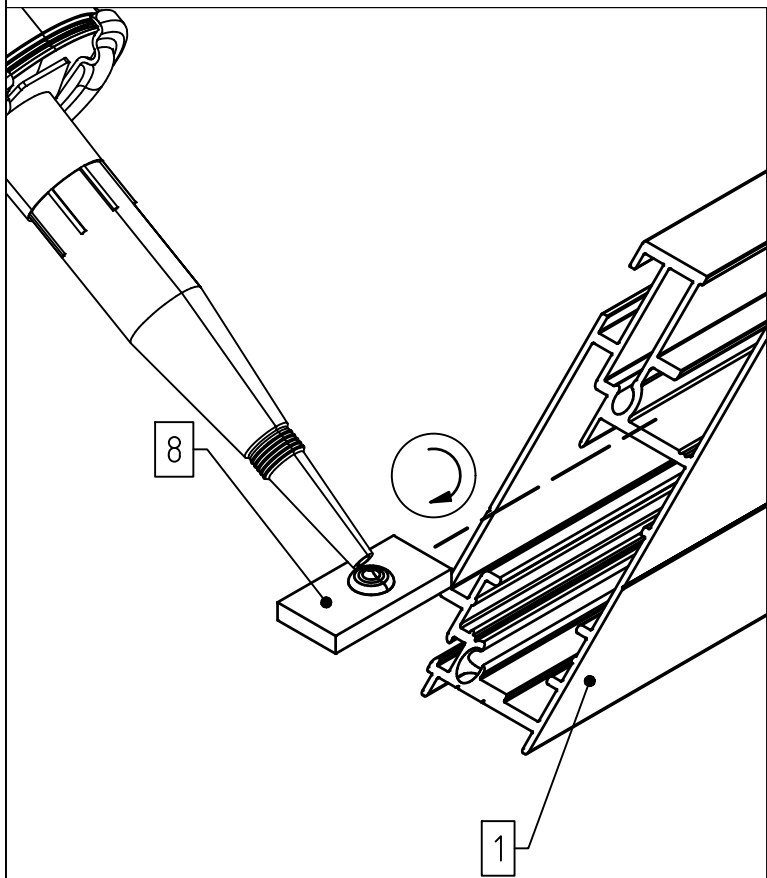

A

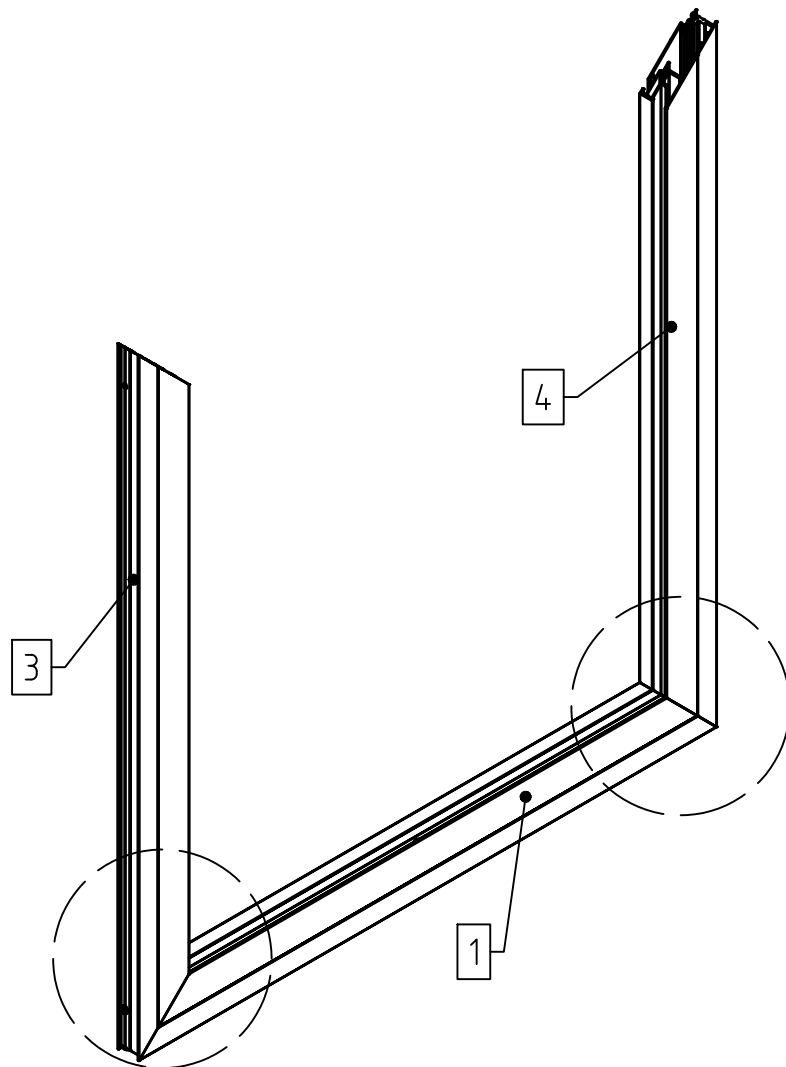

2x

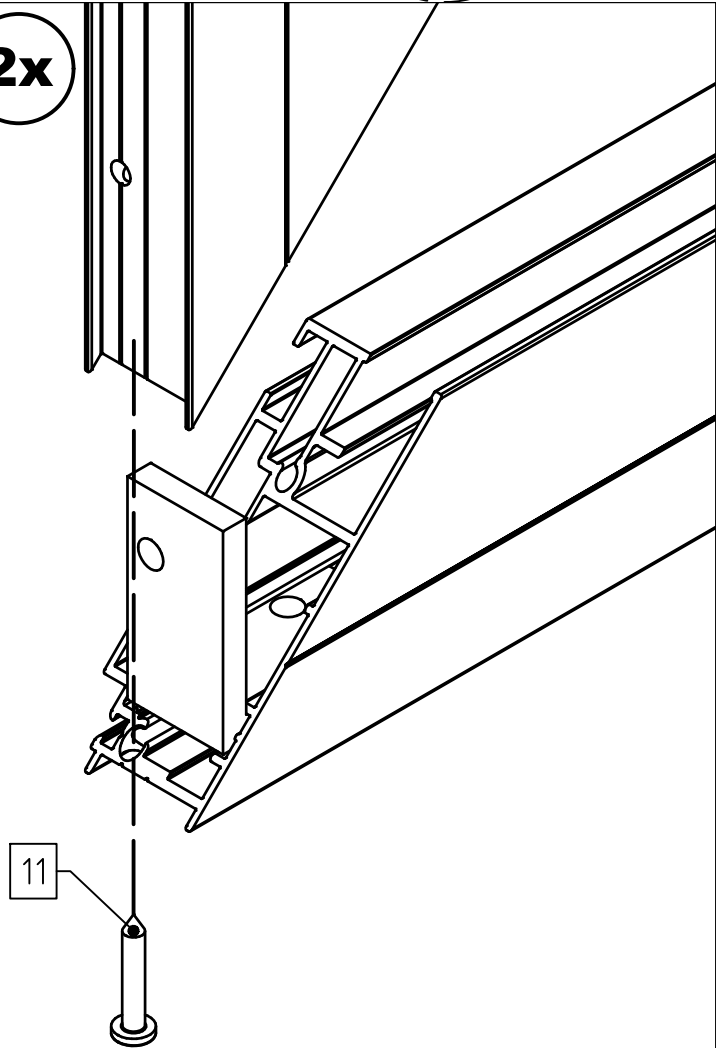

2x

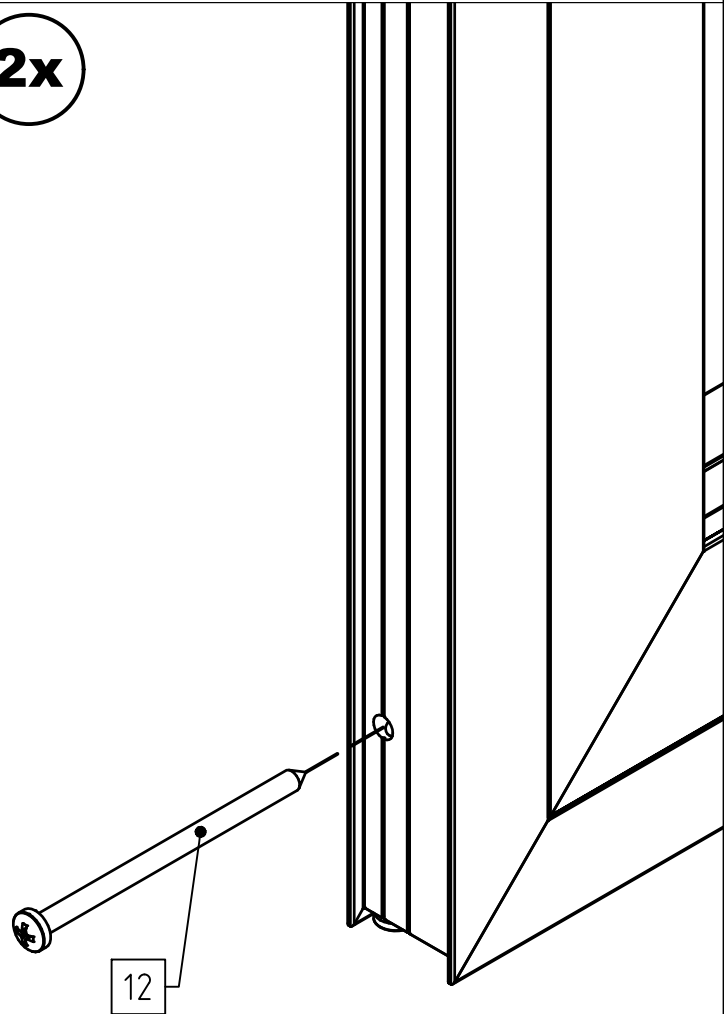

A

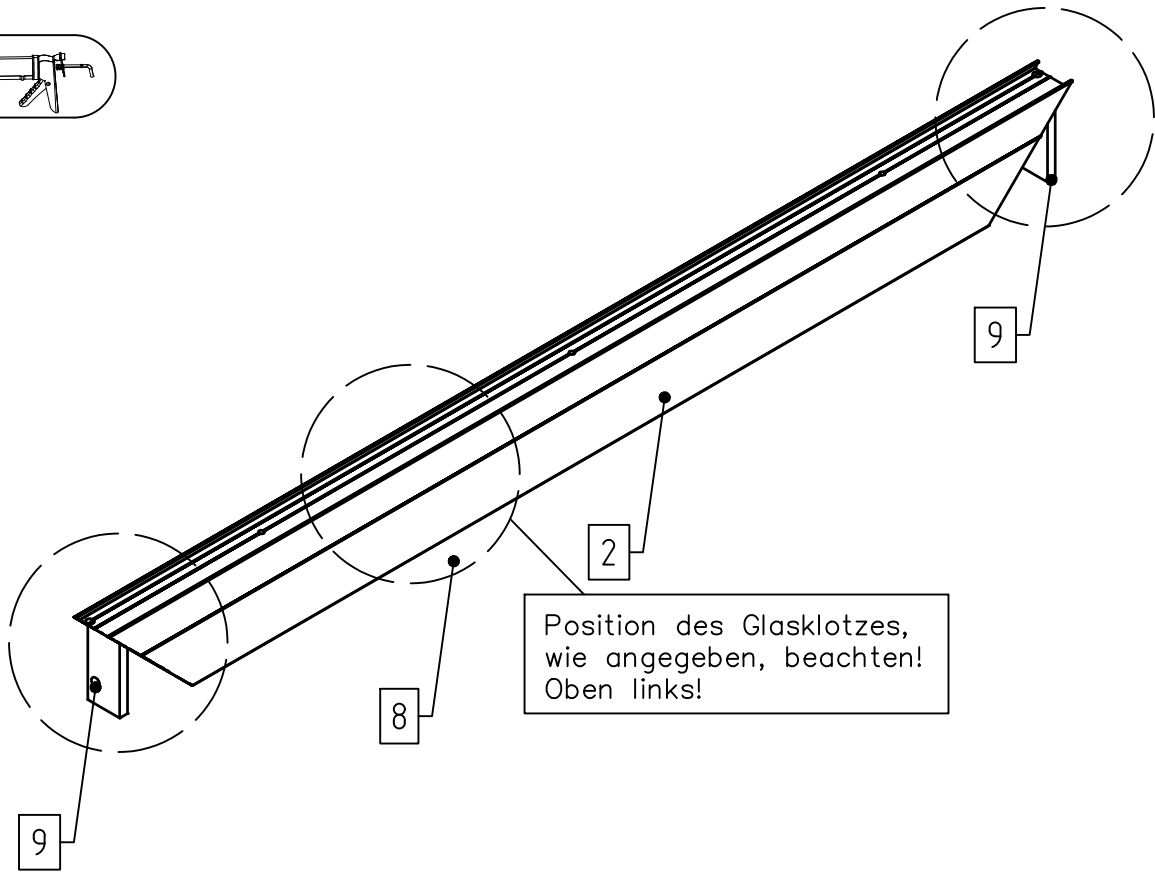
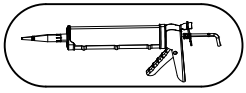

Position des Glasklotzes,
wie angegeben, beachten!
Oben links!

2x

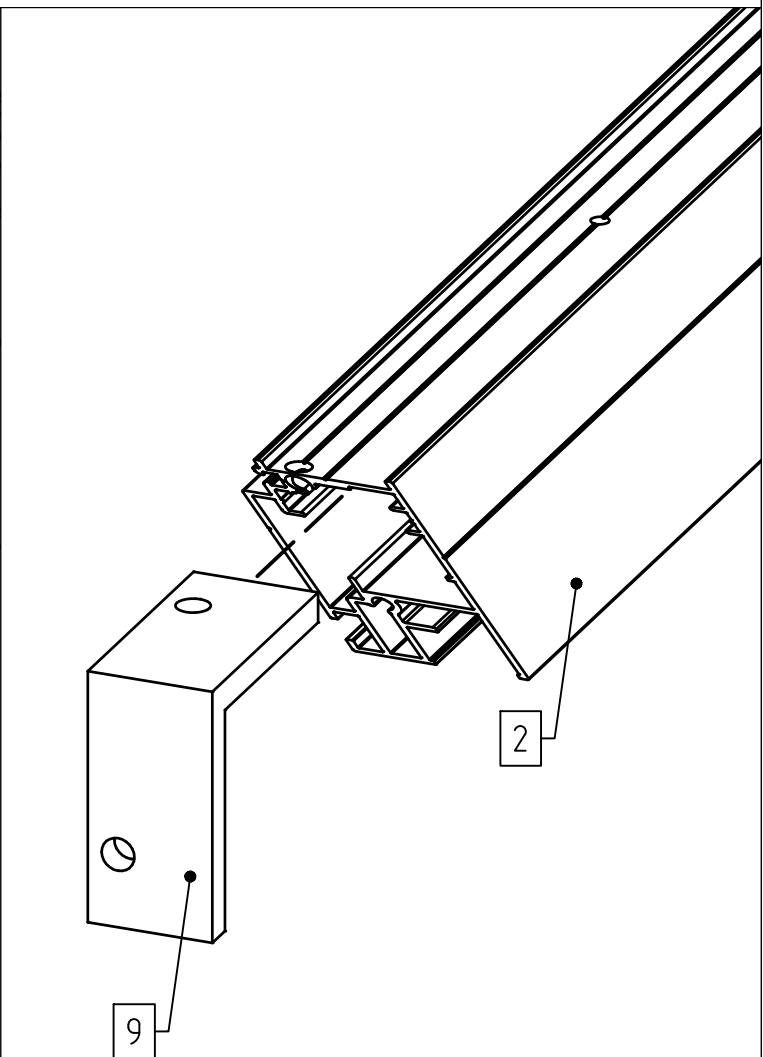
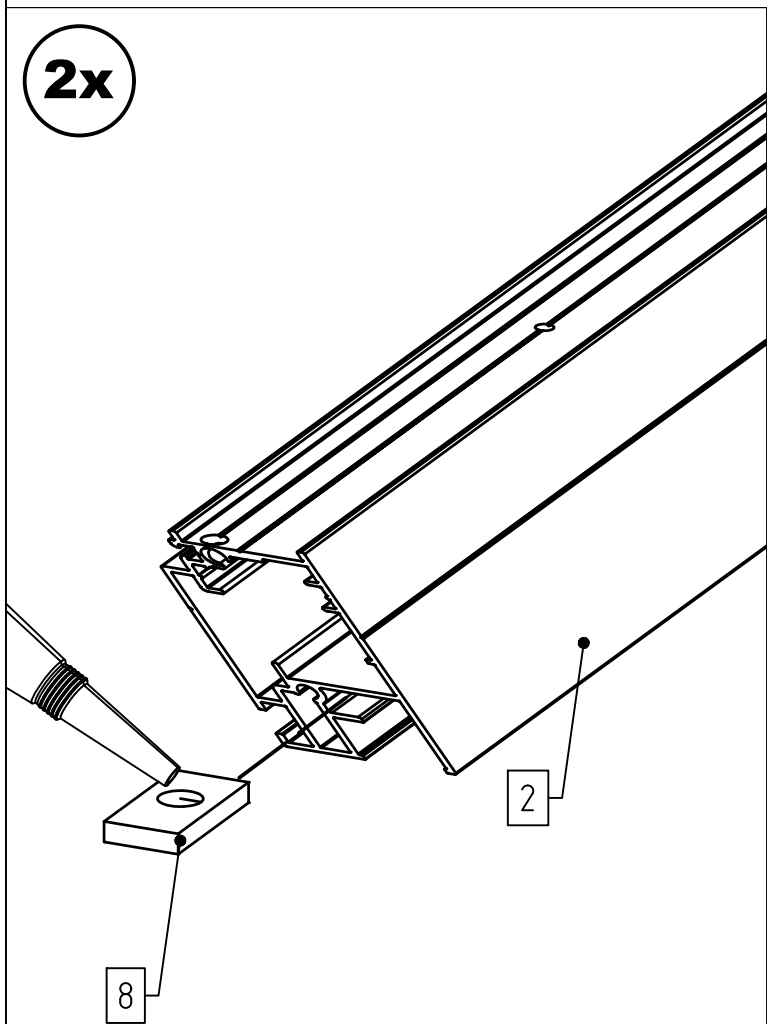

A

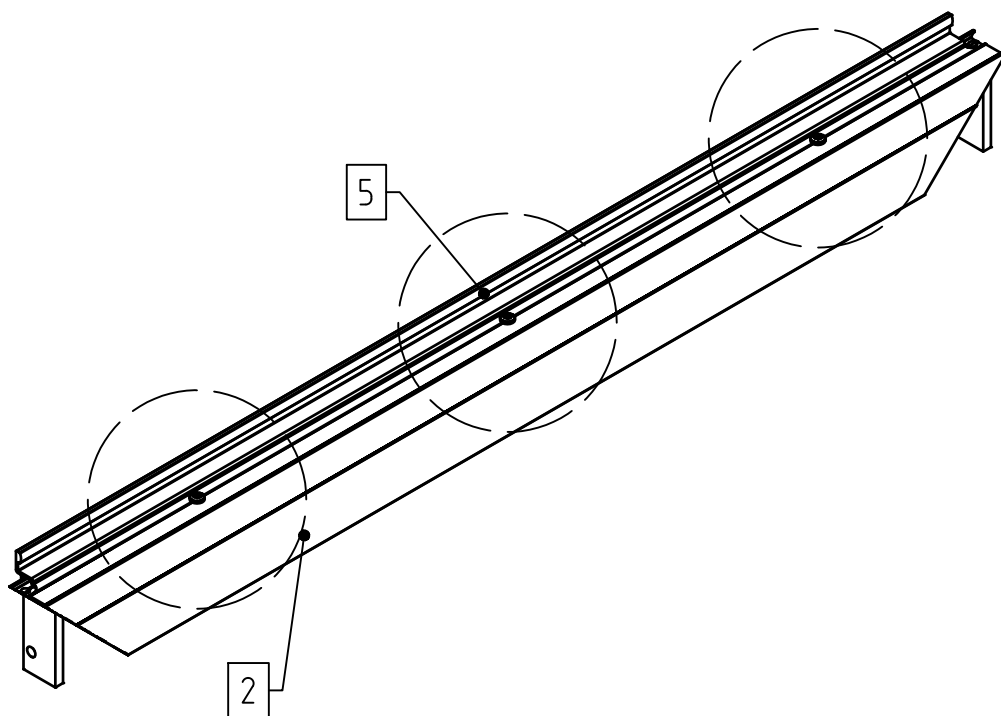

3x

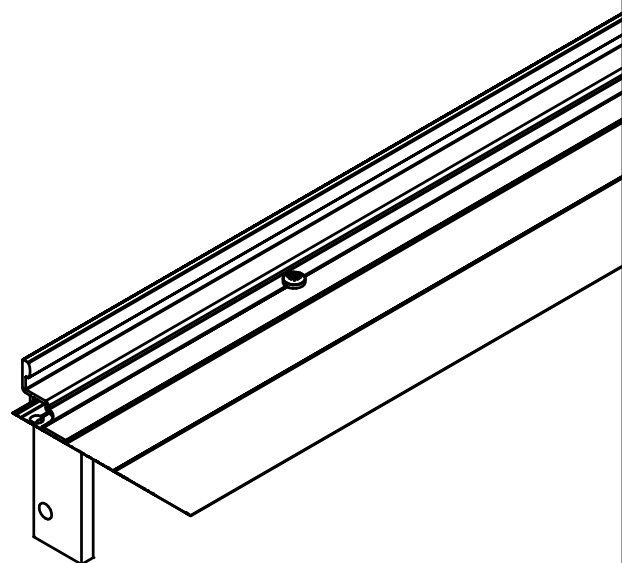
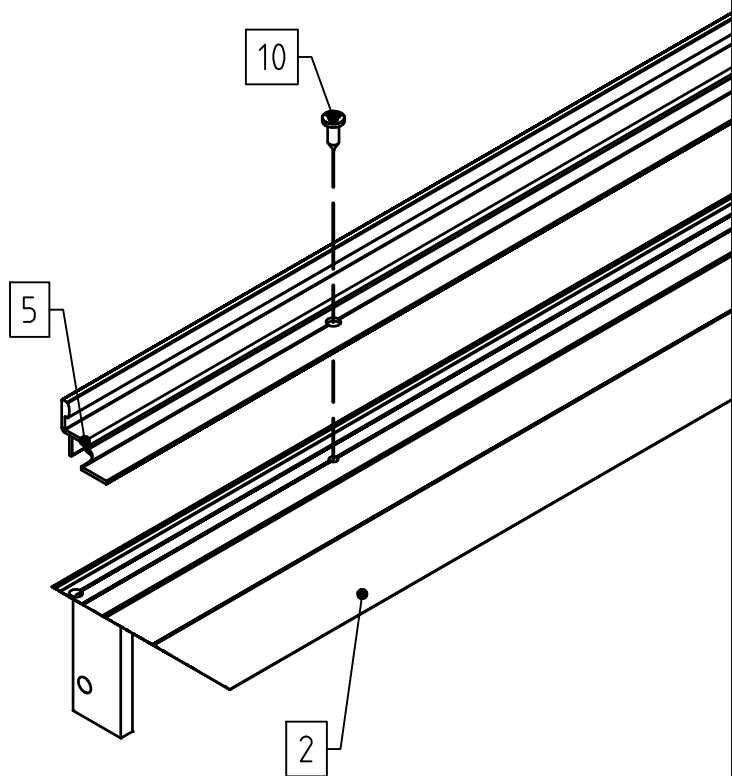

A

16

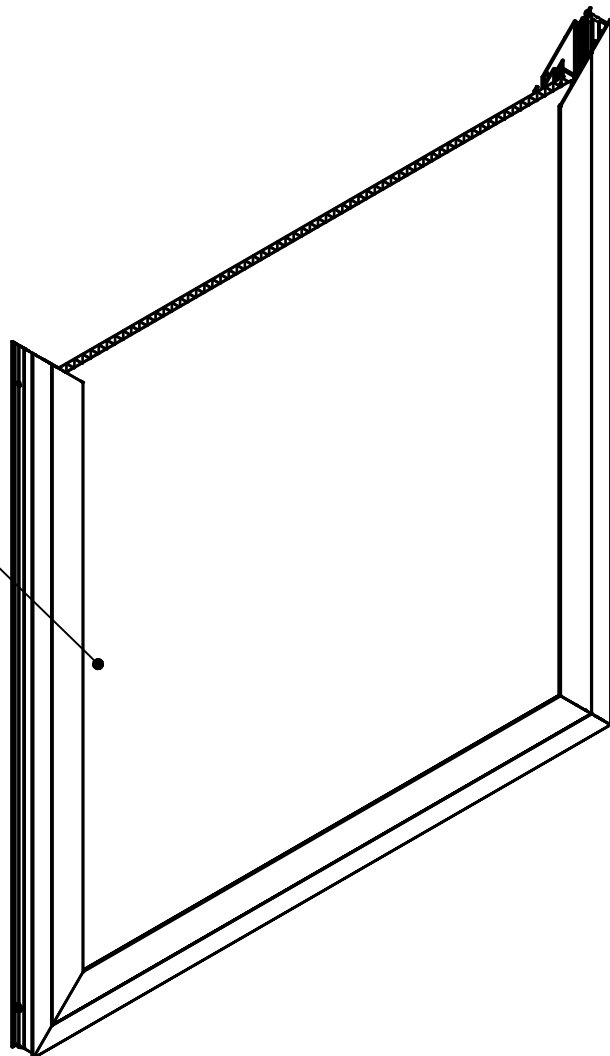

16

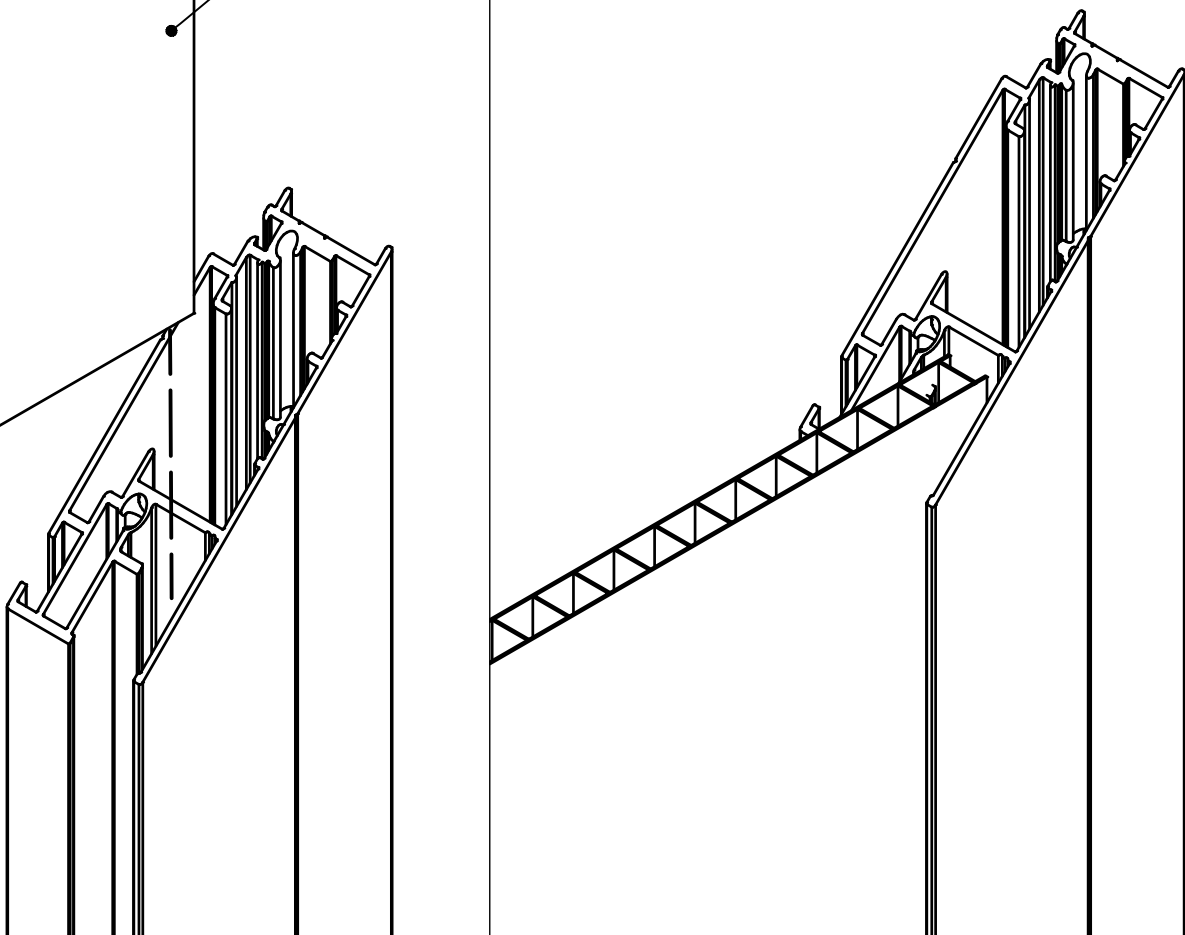

A

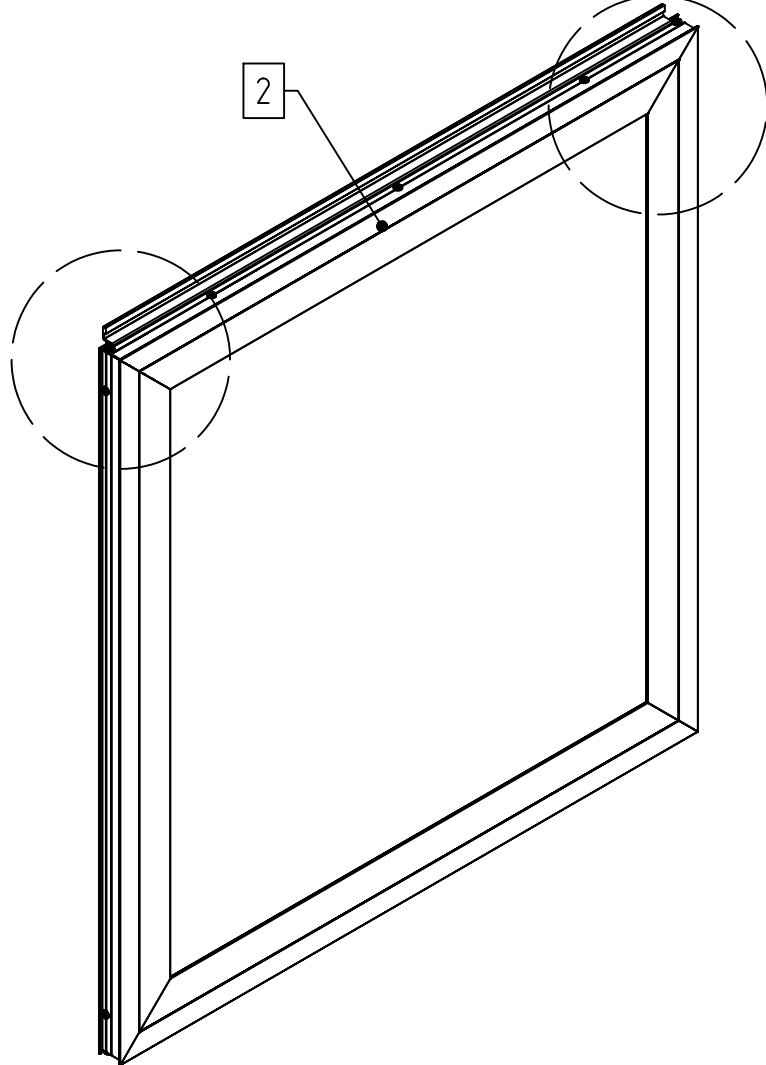

2x

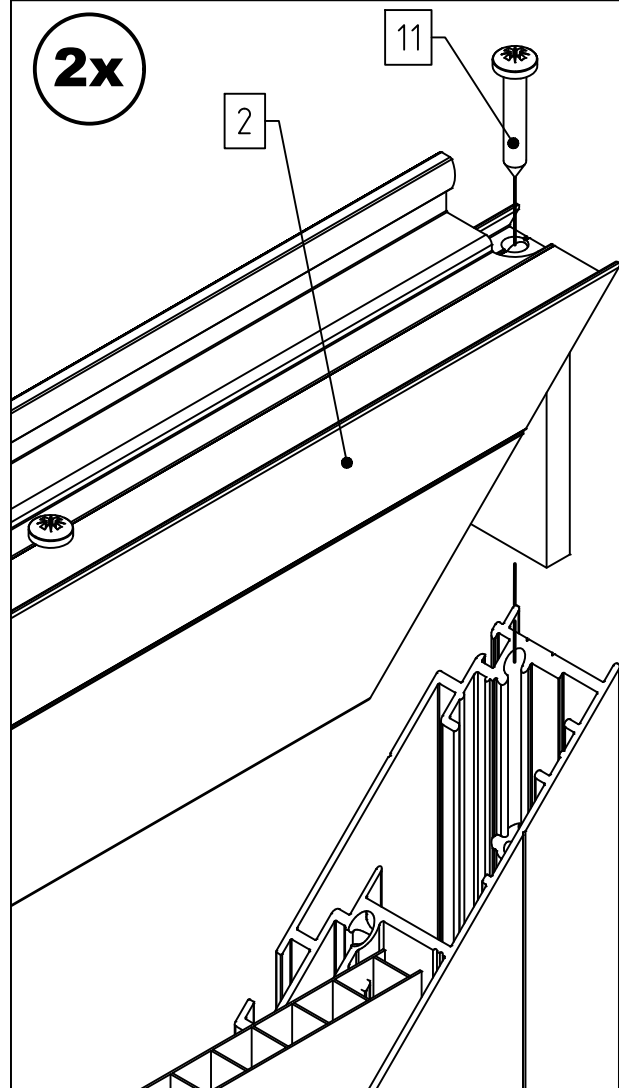

2x

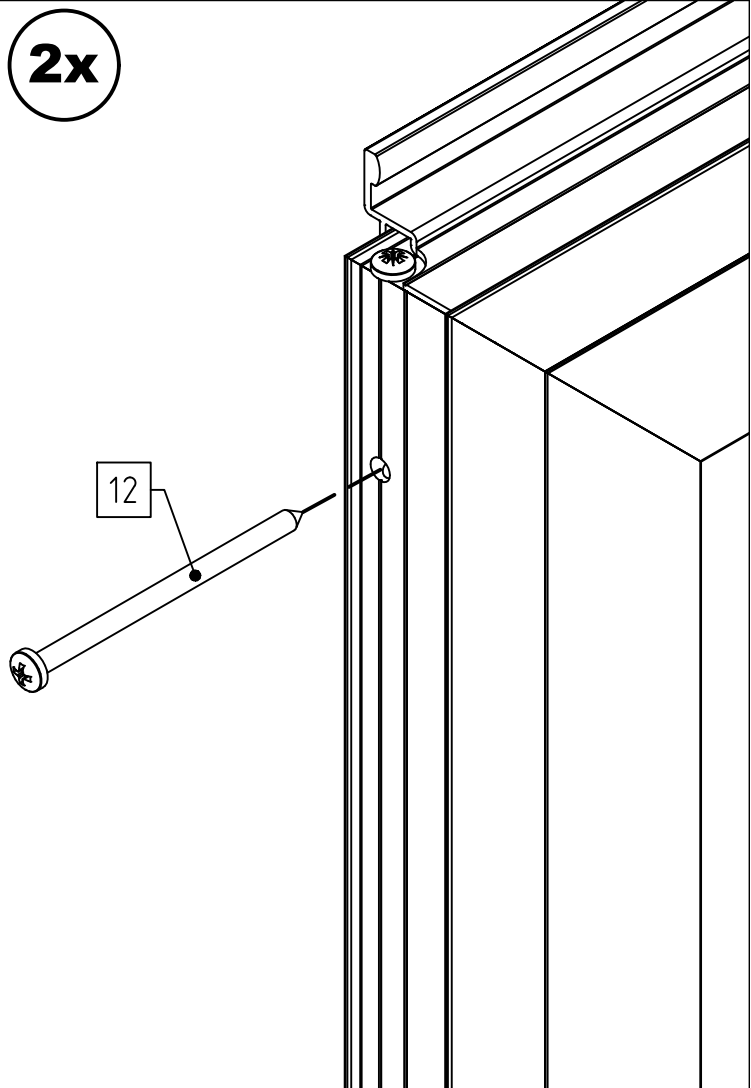

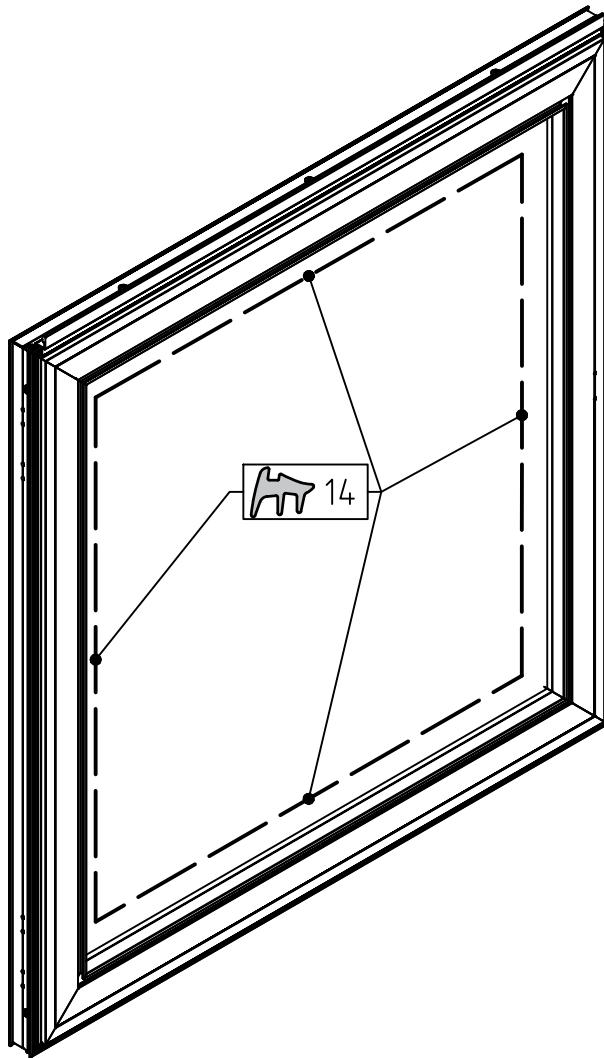

2x

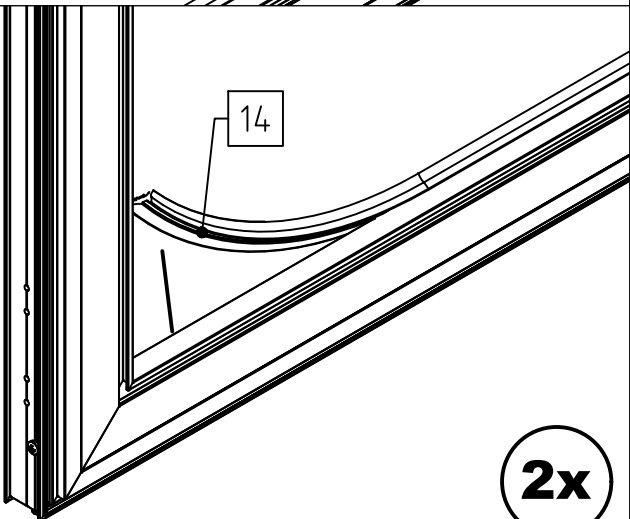
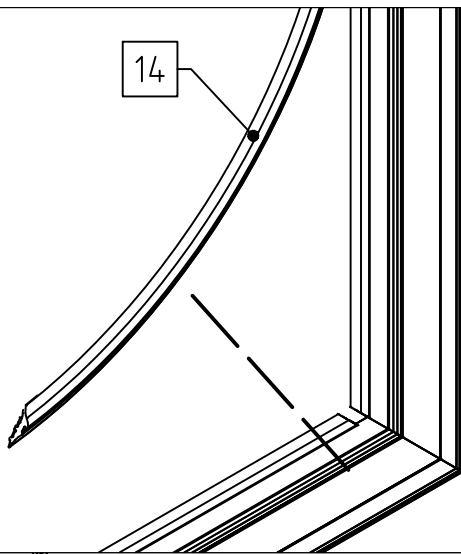

2x

VD

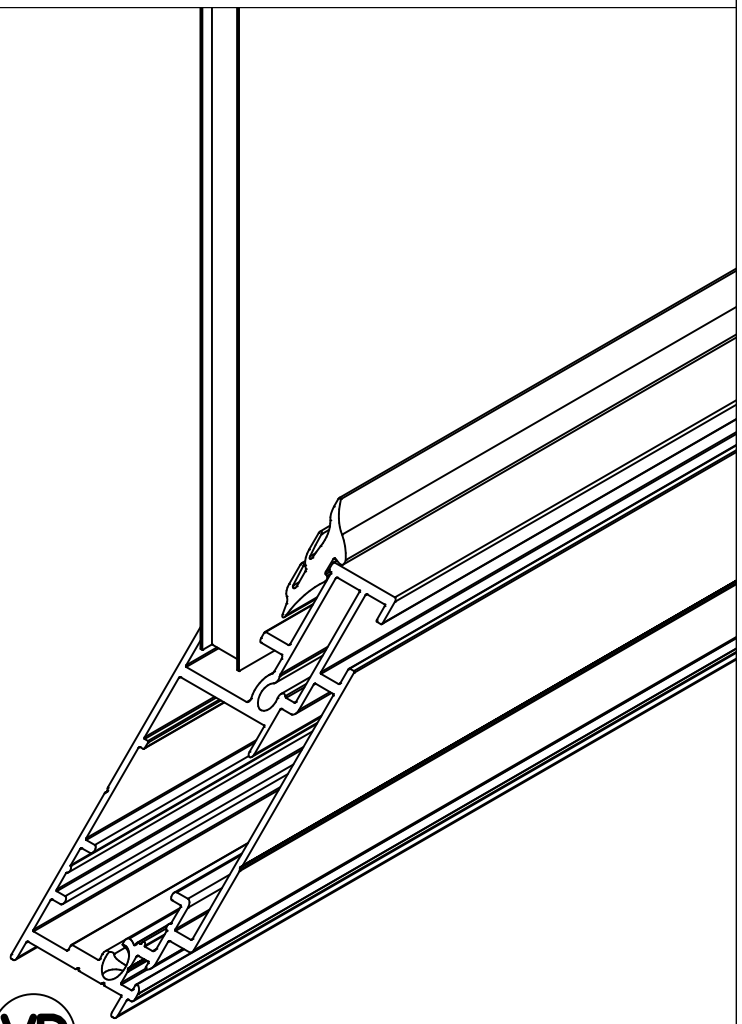

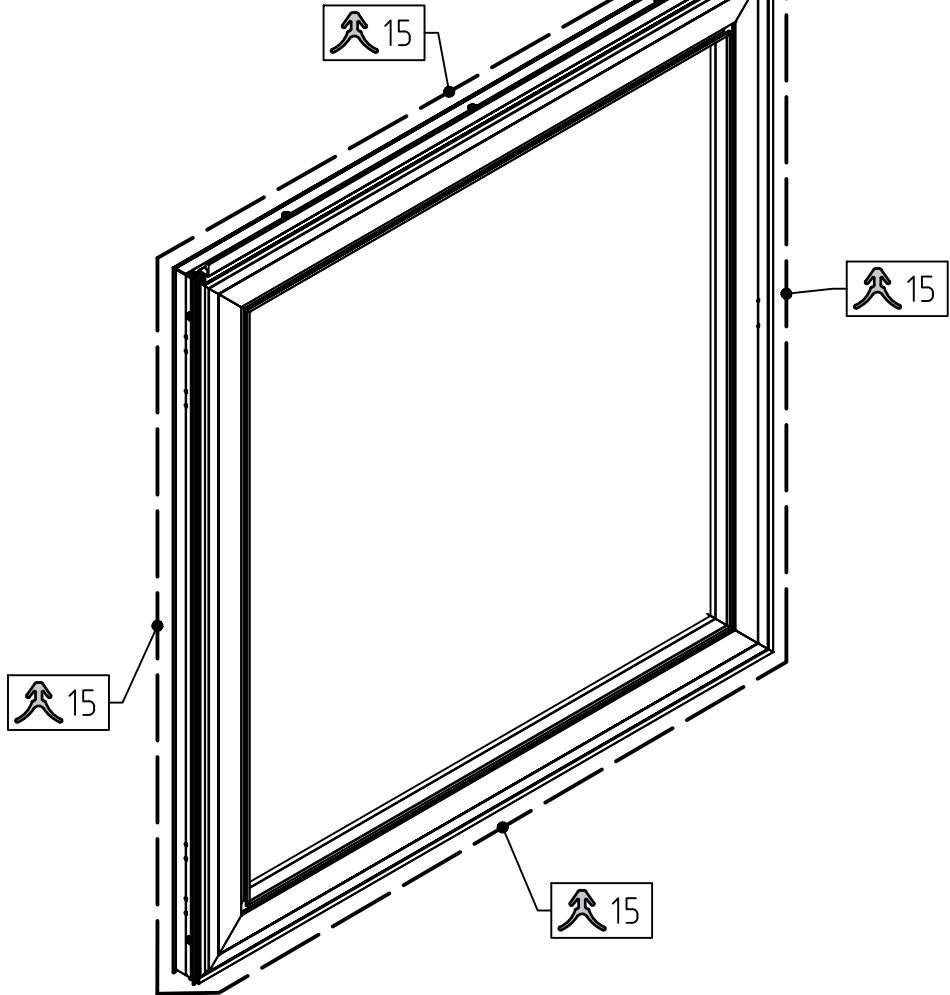

1x

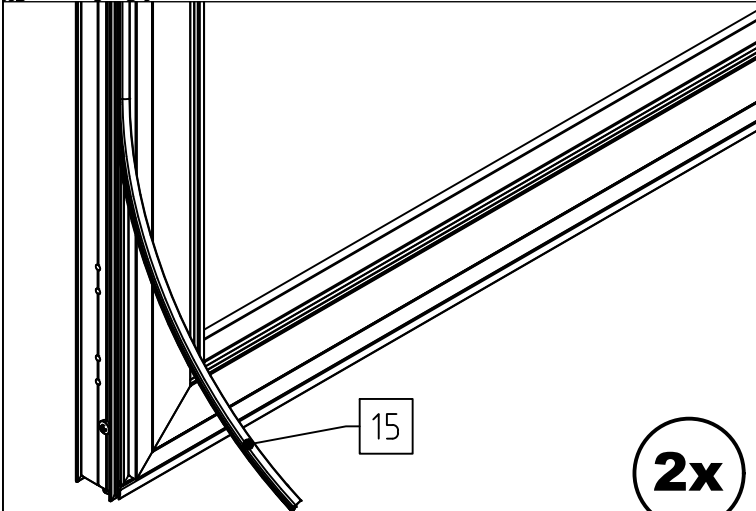
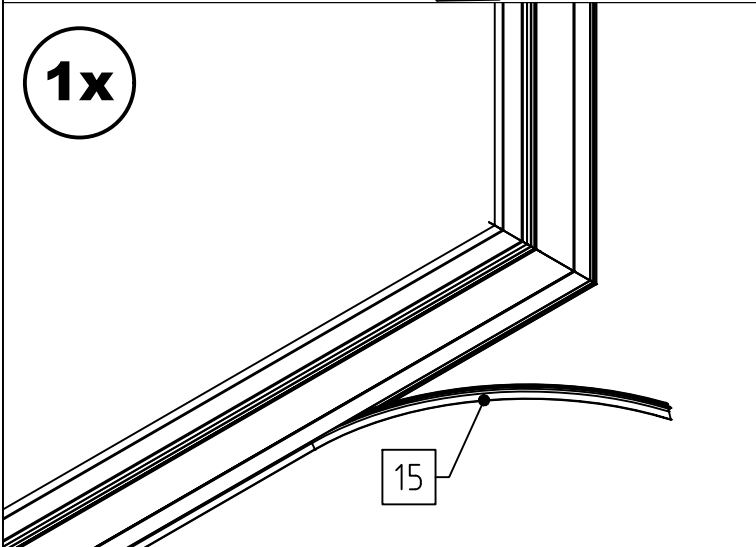

2x

VD

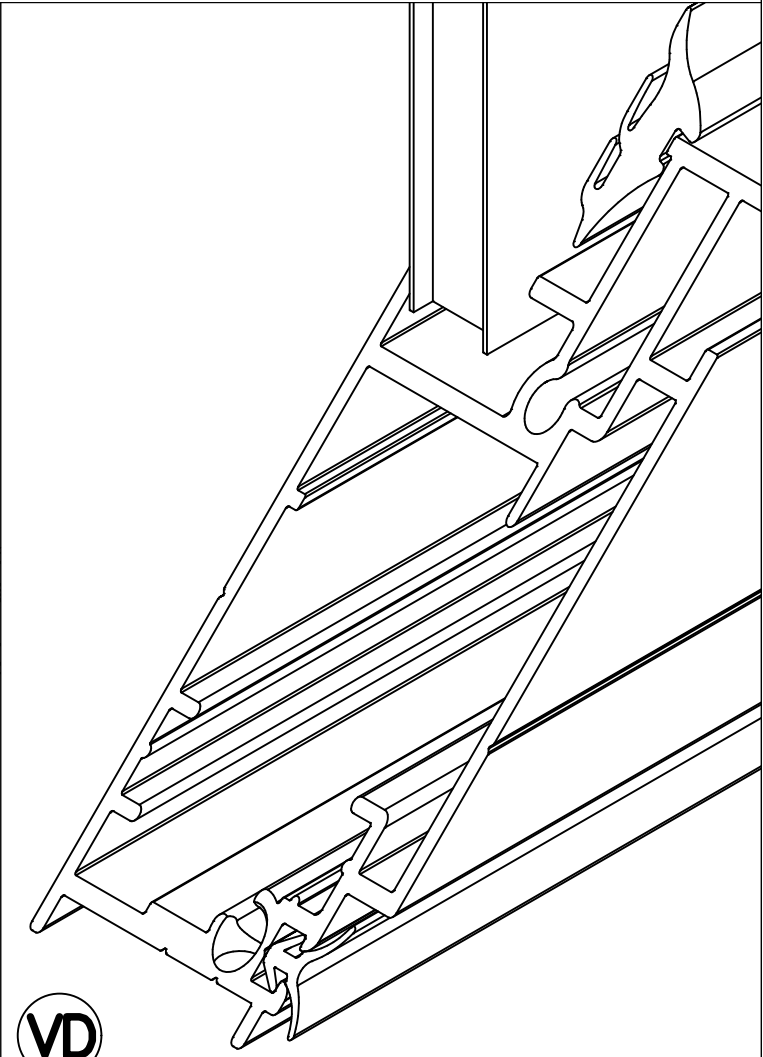

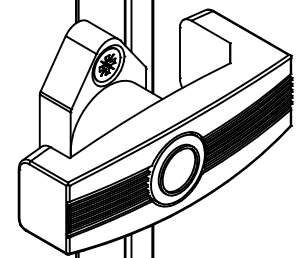
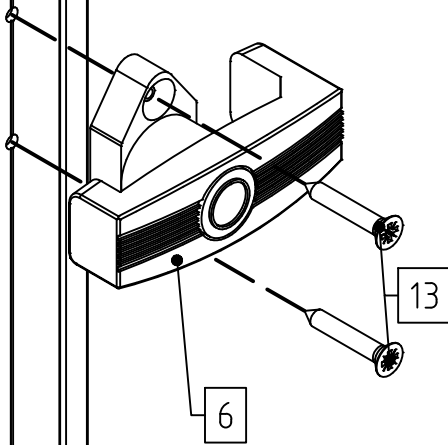
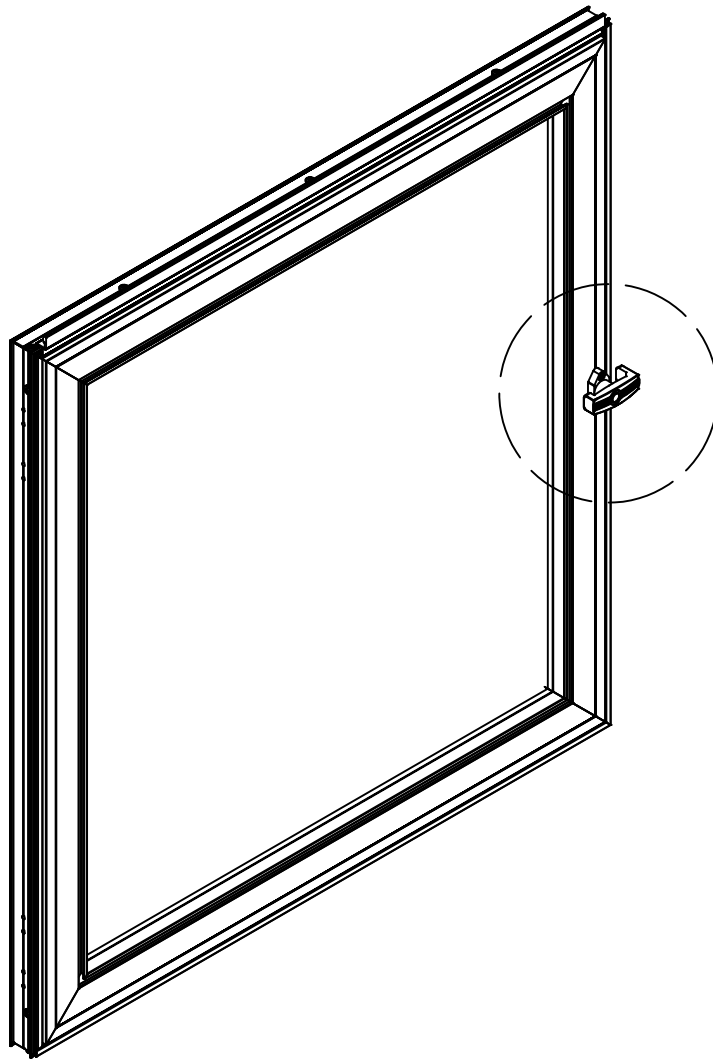

1

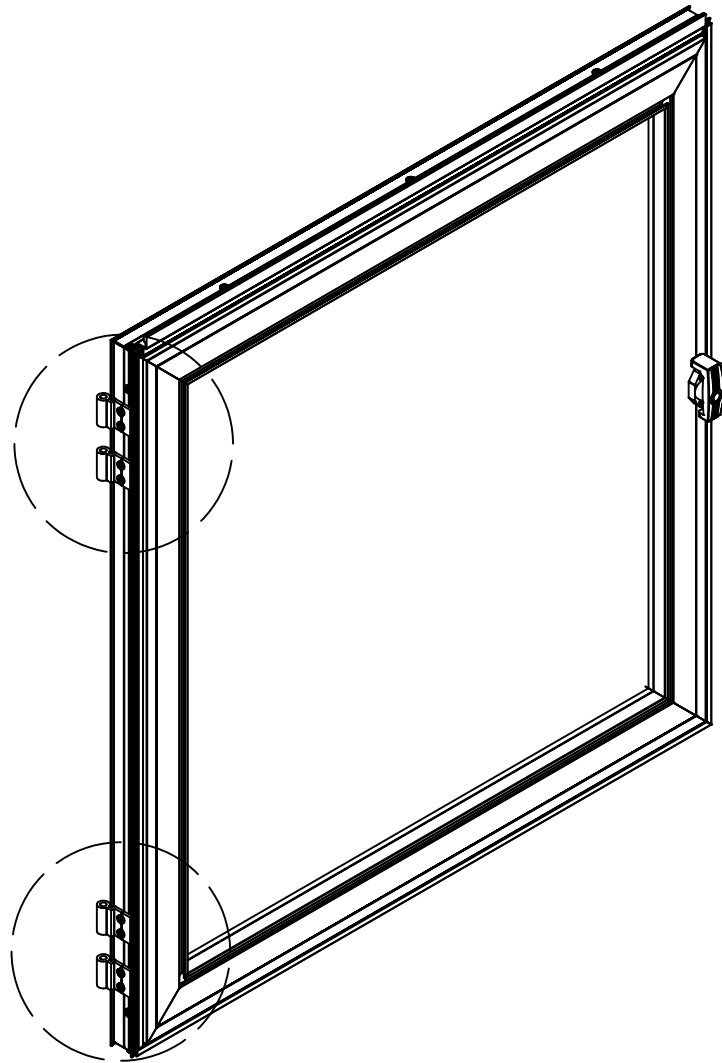

4x

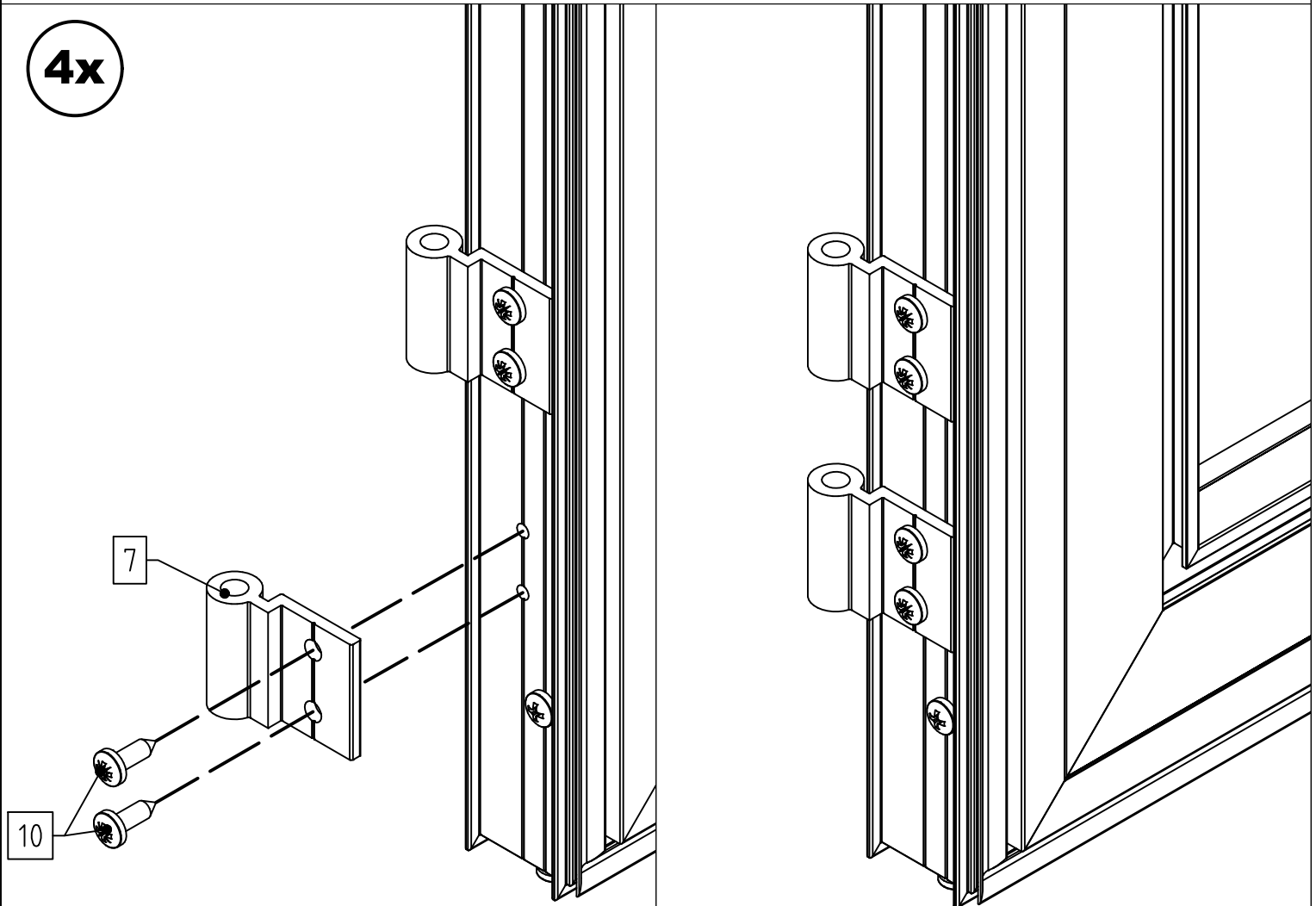



A

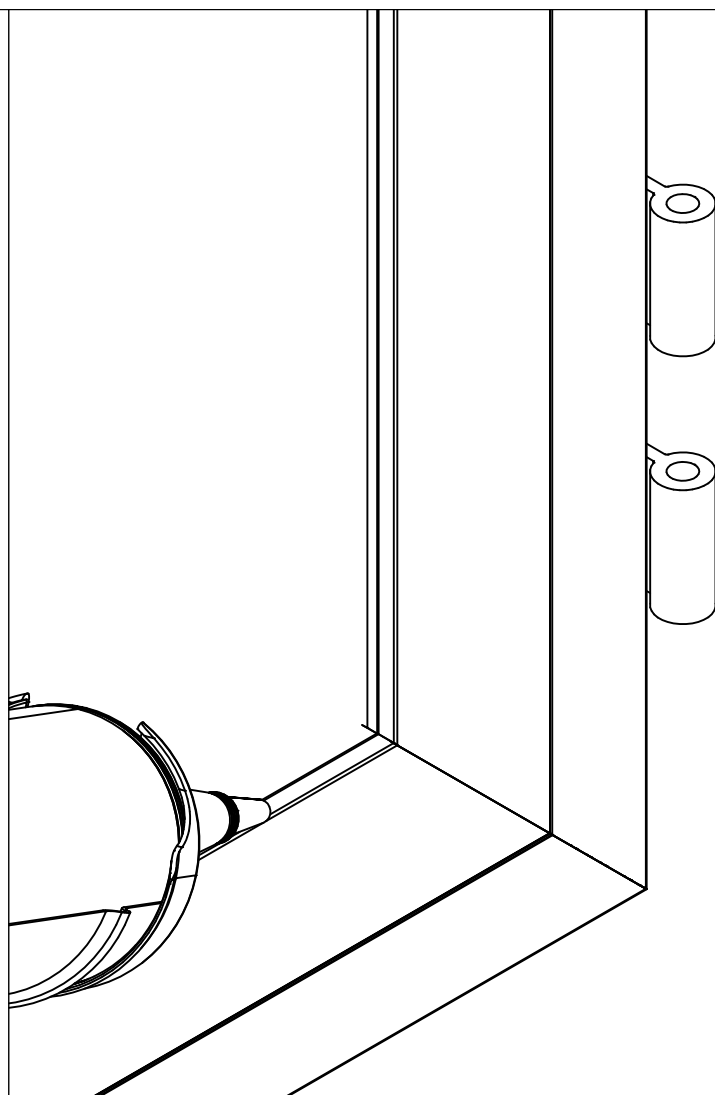
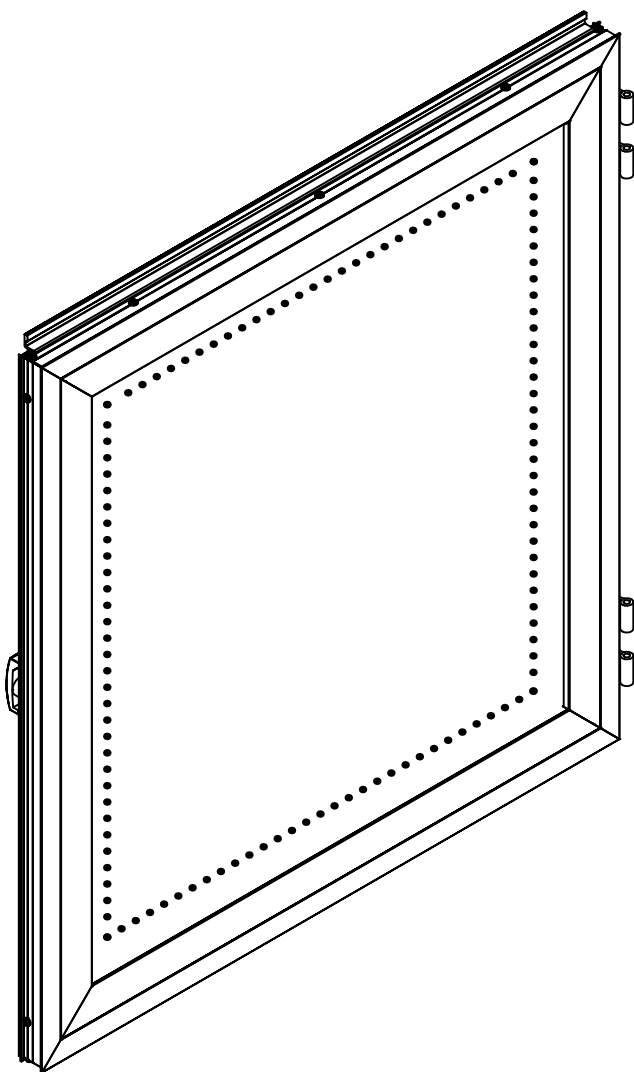
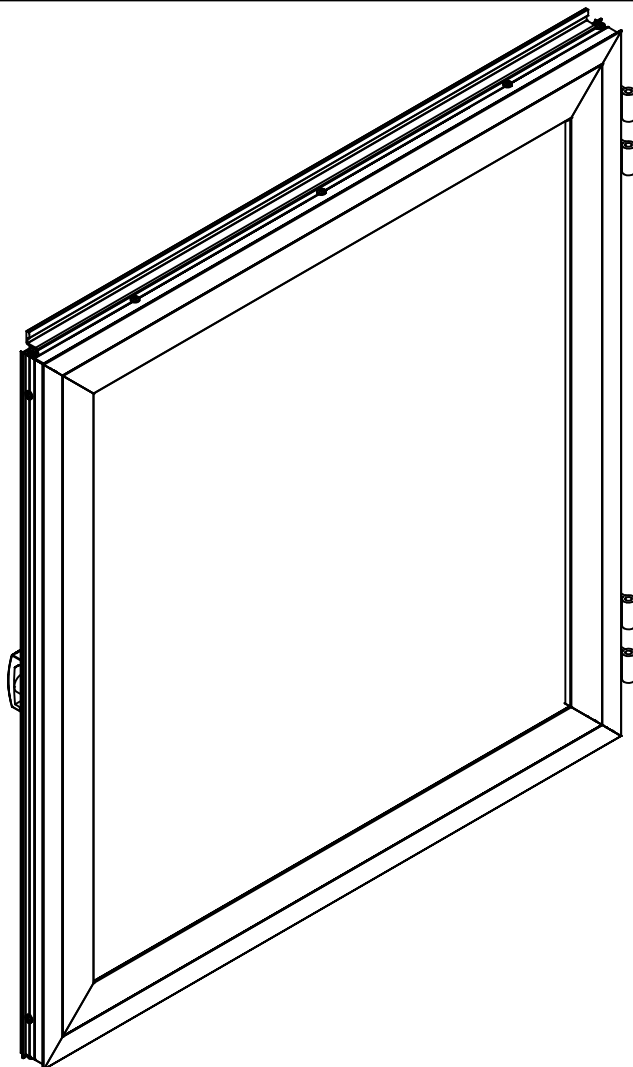
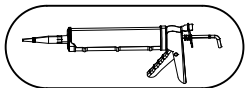

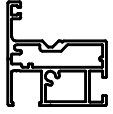
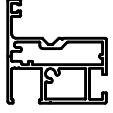
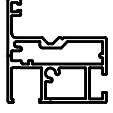
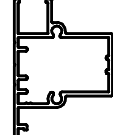
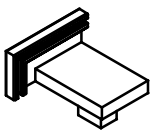
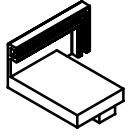
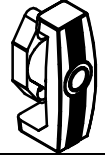
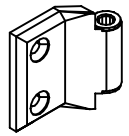
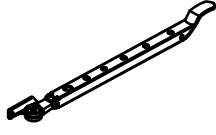
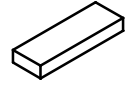
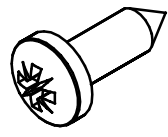
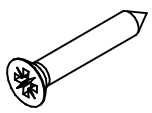

STÜCKLISTE

Rückwandfenster Linea I

Pos.	Abbildung	Art.-Nr.	Bezeichnung	Anzahl	Bemerkung
1		P080-02-01-00-04-1	Türflügelprofil 10mm oben	1	700 mm
2		P080-06-01-00-04-1	Türflügelprofil 10 mm links (Vorreiber)	1	1081 mm
3		P080-07-01-00-04-1	Türflügelprofil 10 mm rechts (Scharnier)	1	1081 mm
4		P081-04-01-00-04-1	Querriegel 10 mm unten (Aufsteller)	1	700 mm
5		9999000011	Eckverbinder Türflügel rechts	1	
6		9999000009	Eckverbinder Türflügel links	1	
7		9999000023	Vorreiber	1	
8		9999000358	Scharnieroberteil (inkl. Buchsen)	2	
9		9999000390	Fensteraufsteller	1	
10		9999000672	Verglasungsklotz 30 x 10 x 4 mm (aus Kömacell)	2	
11		9999000144	Linsenkopfschraube 4,2 x 13	2	DIN 7981
12		9999000152	Senkkopfschraube 3,5 x 22	2	DIN 7982

STÜCKLISTE

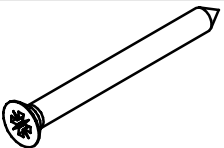
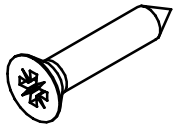
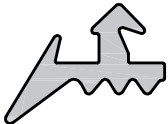
Rückwandfenster Linea I

Pos.	Abbildung	Art.-Nr.	Bezeichnung	Anzahl	Bemerkung
13		9999000160	Senkkopfschraube 4,2 x 45	6	DIN 7982
14		9999000163	Senkkopfschraube 4,8 x 25	4	DIN 7982
15		9999000376	Sprossendichtung 2 mm	4,5 lfdm	
16			PC-Hohlkammerplatte 724x1031 mm	1	
17					
18					
19					
20					
21					
22					
23					
24					

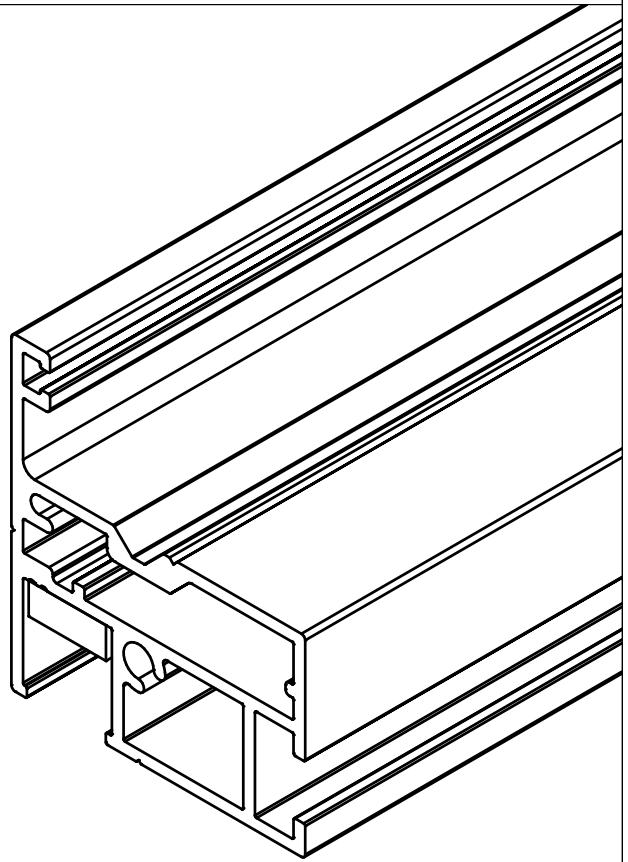
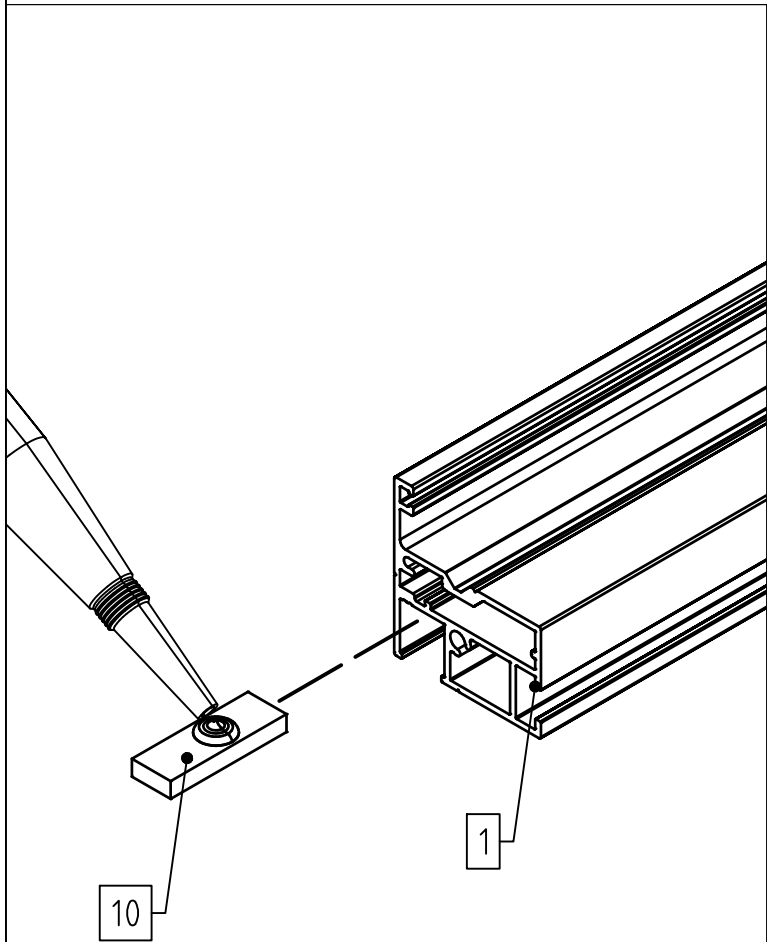
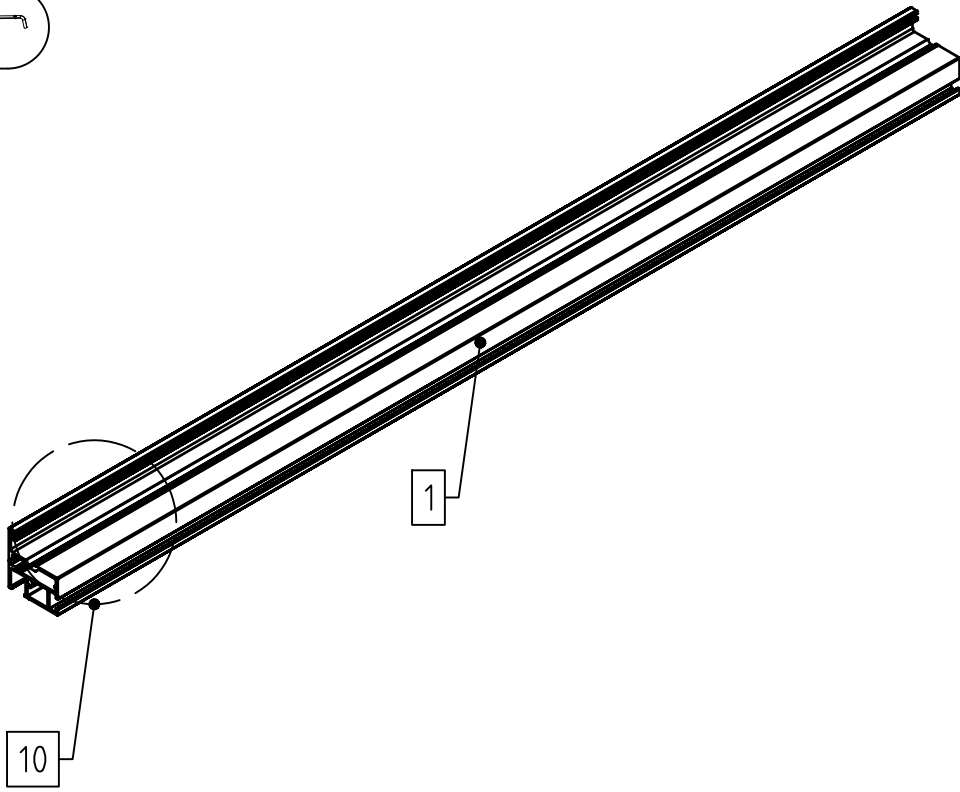
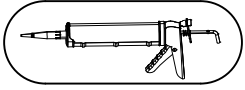

1

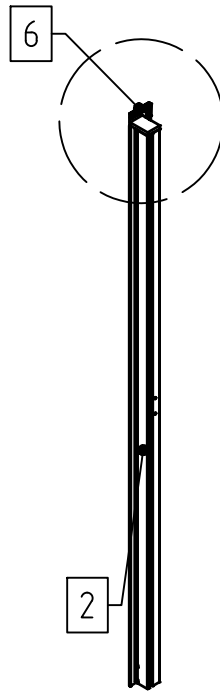
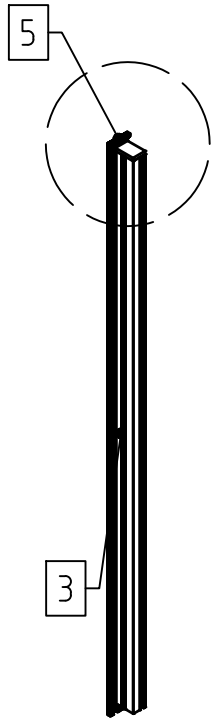

2x

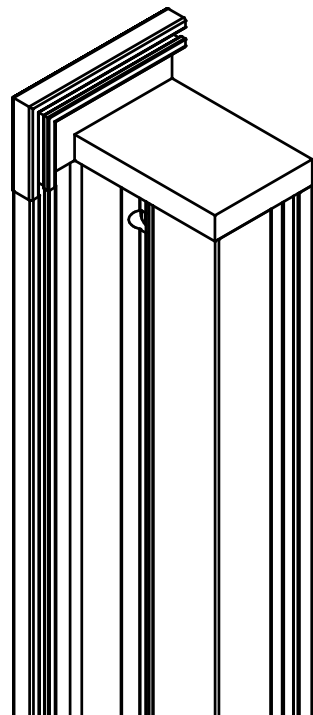
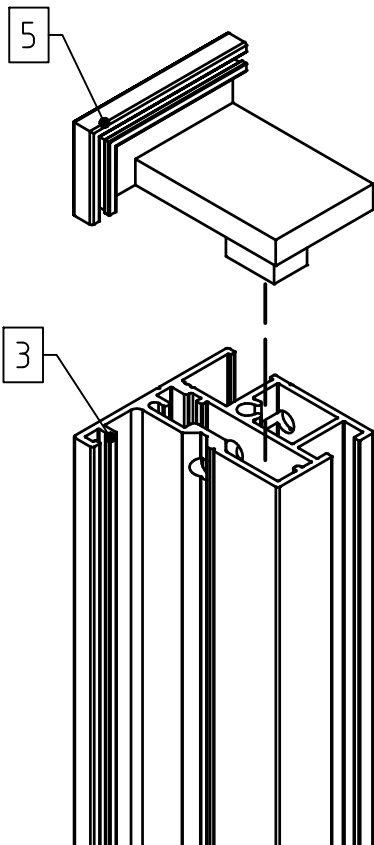

1

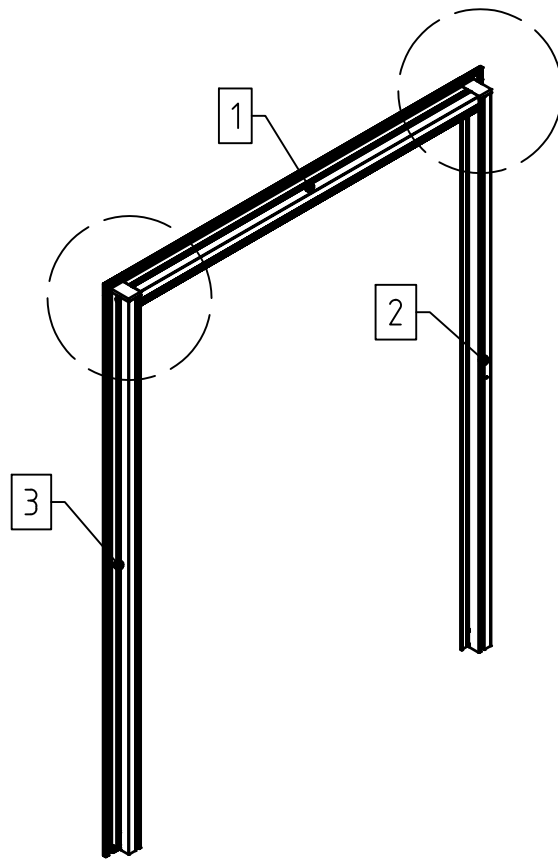

2x

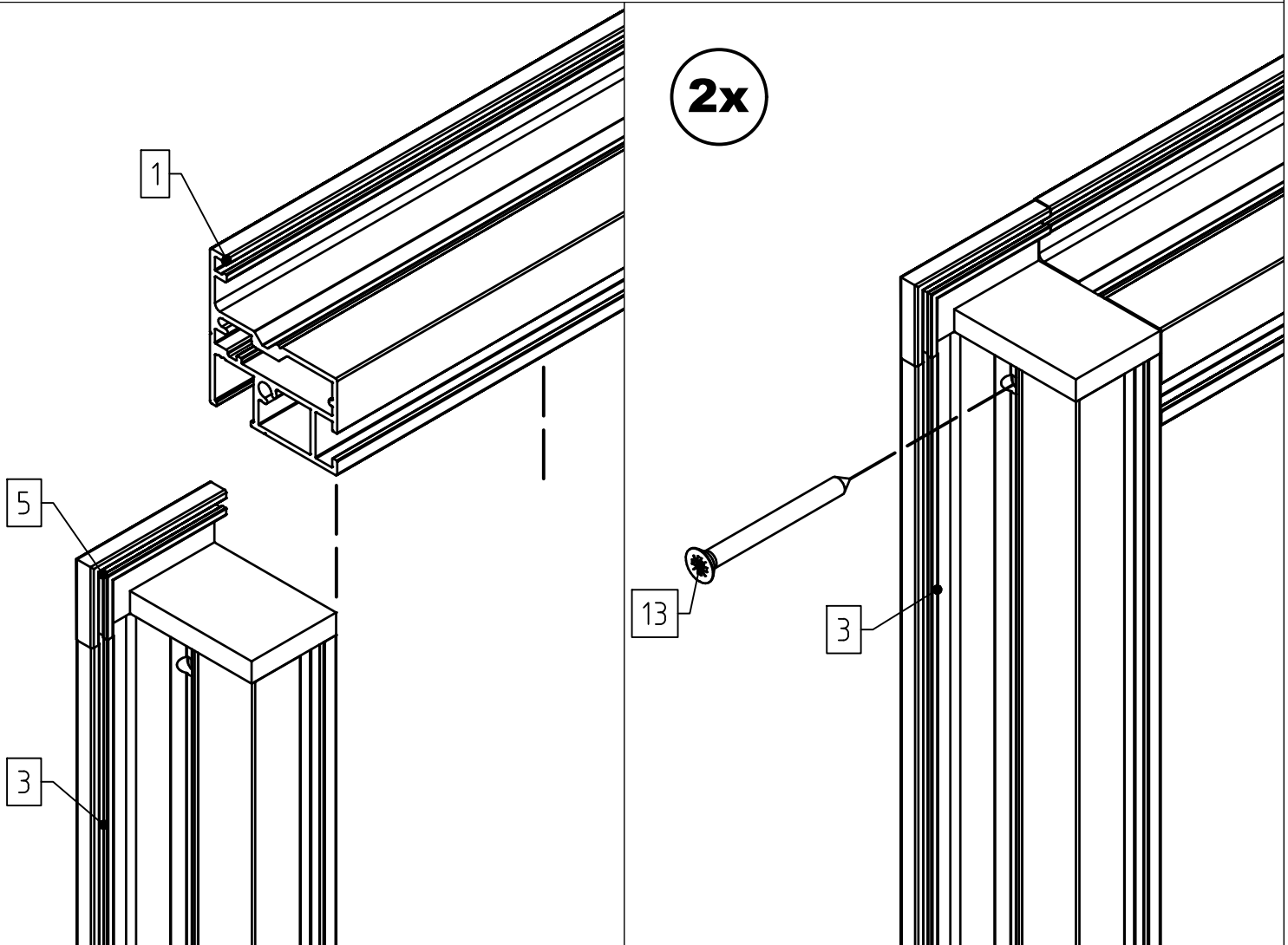

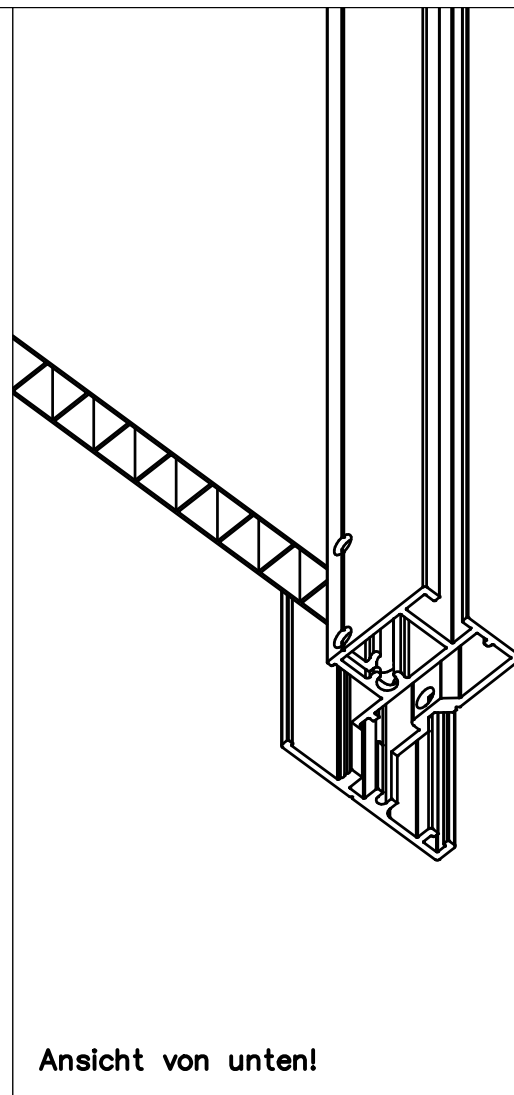
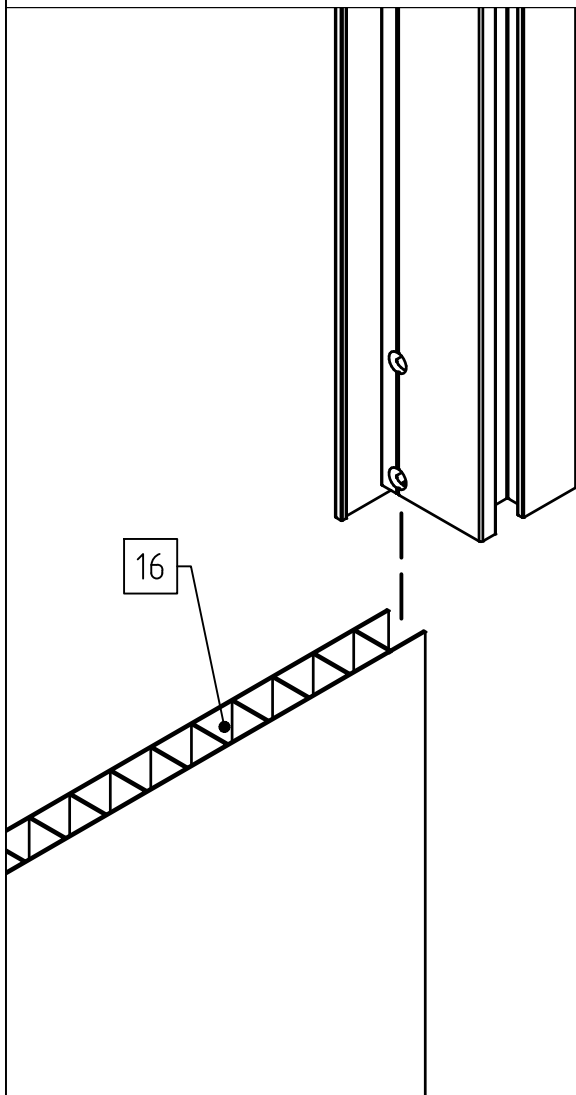
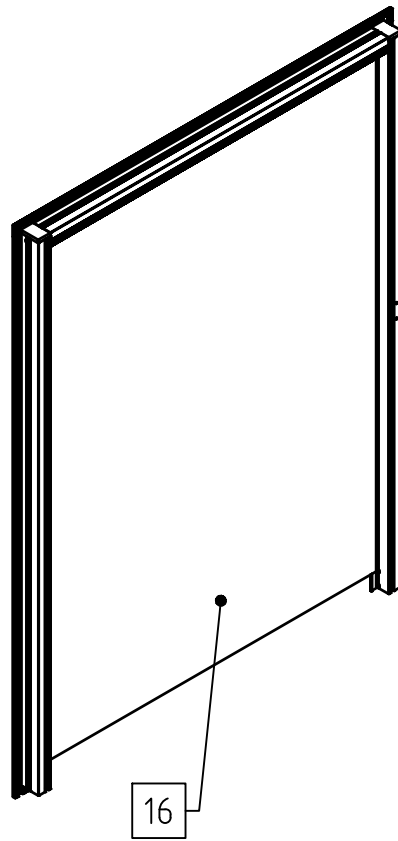

Ansicht von unten!

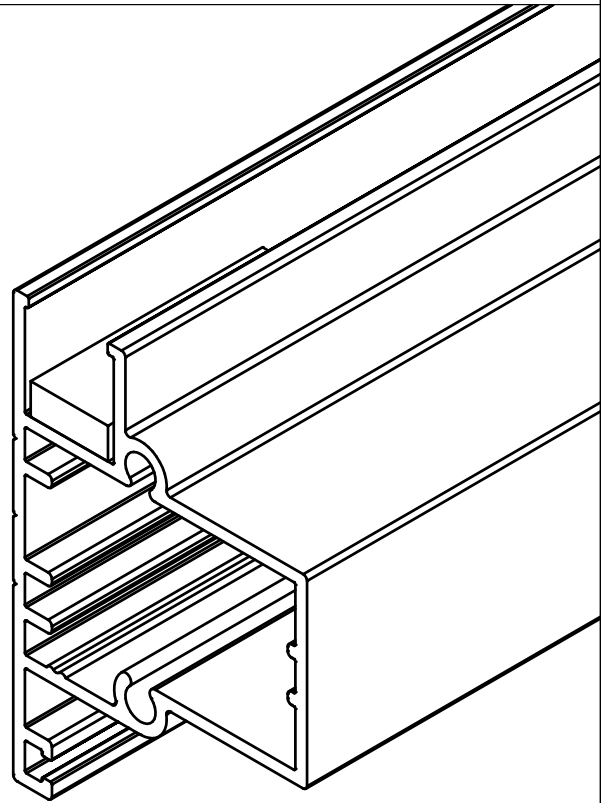
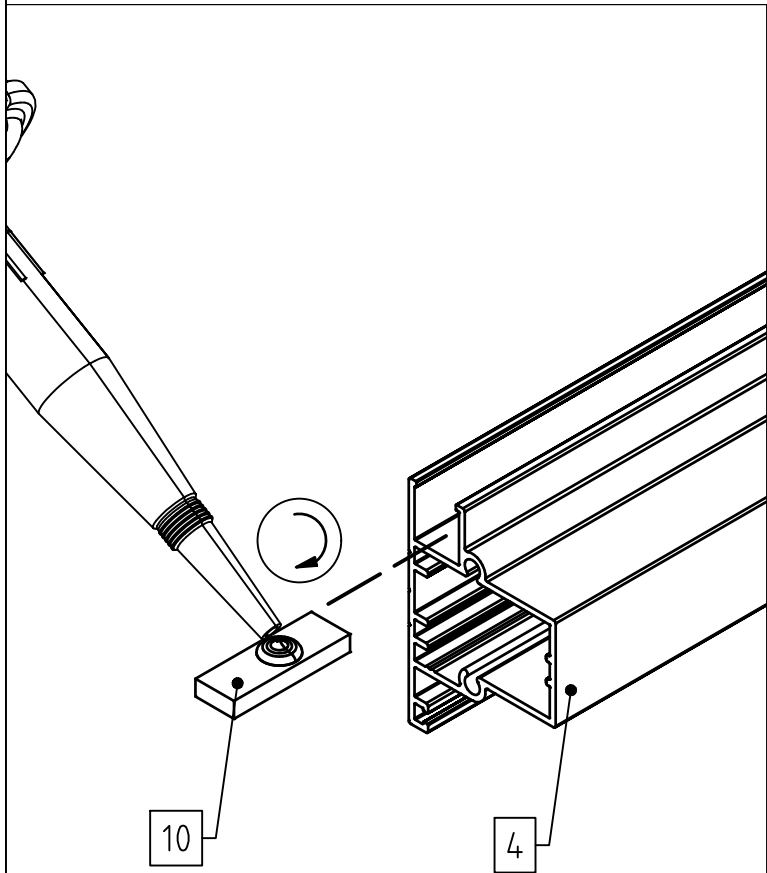
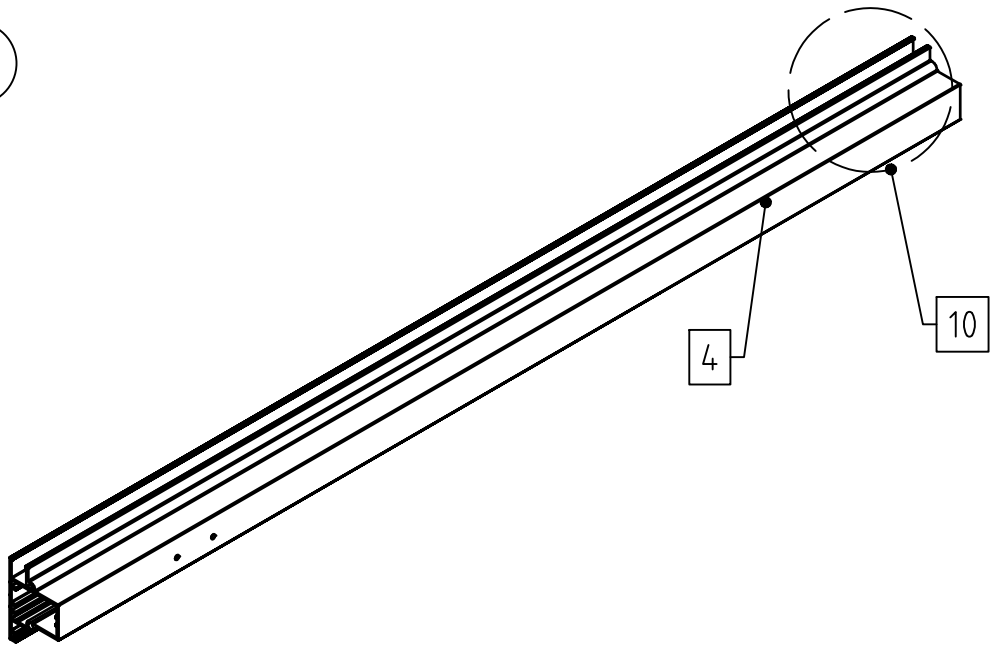
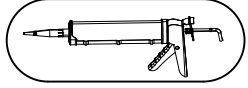

1

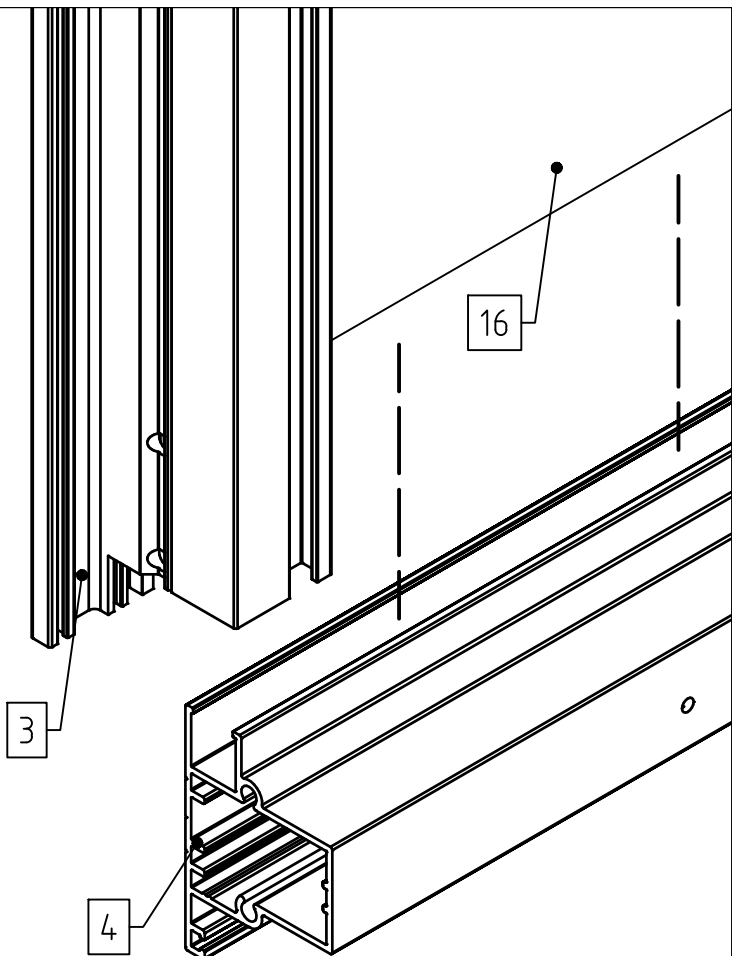
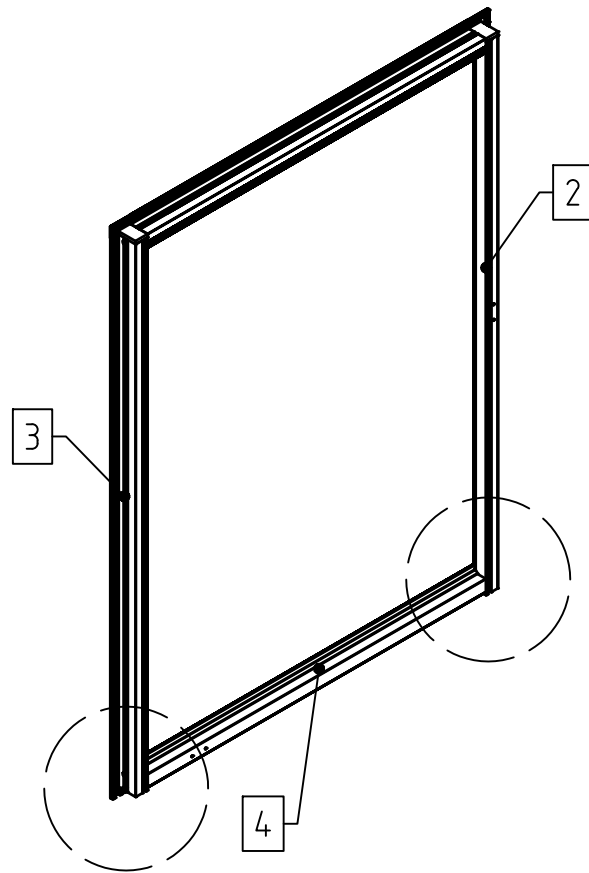

2x

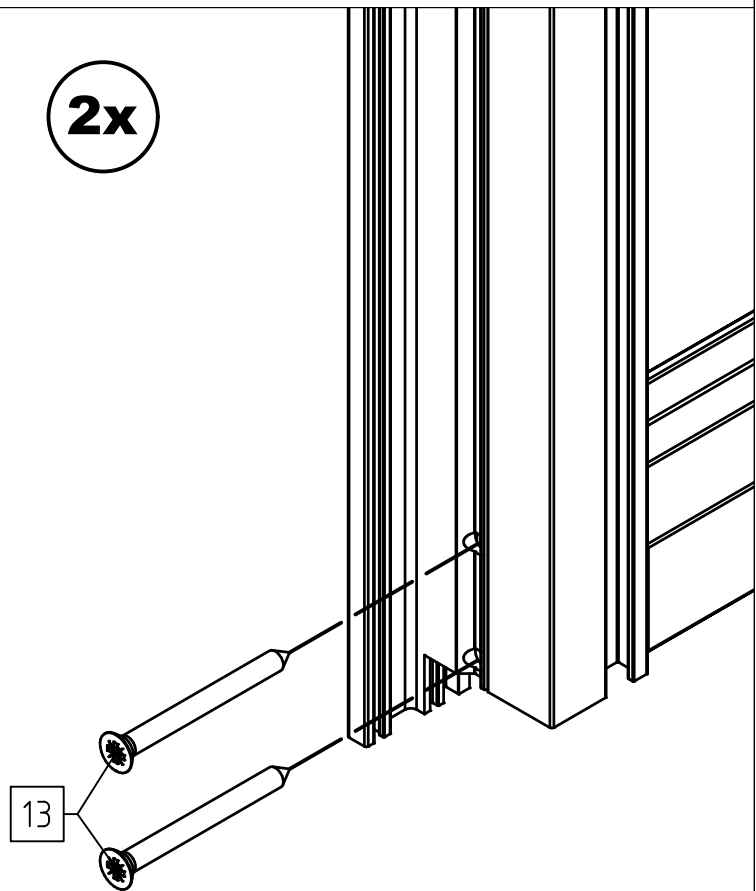

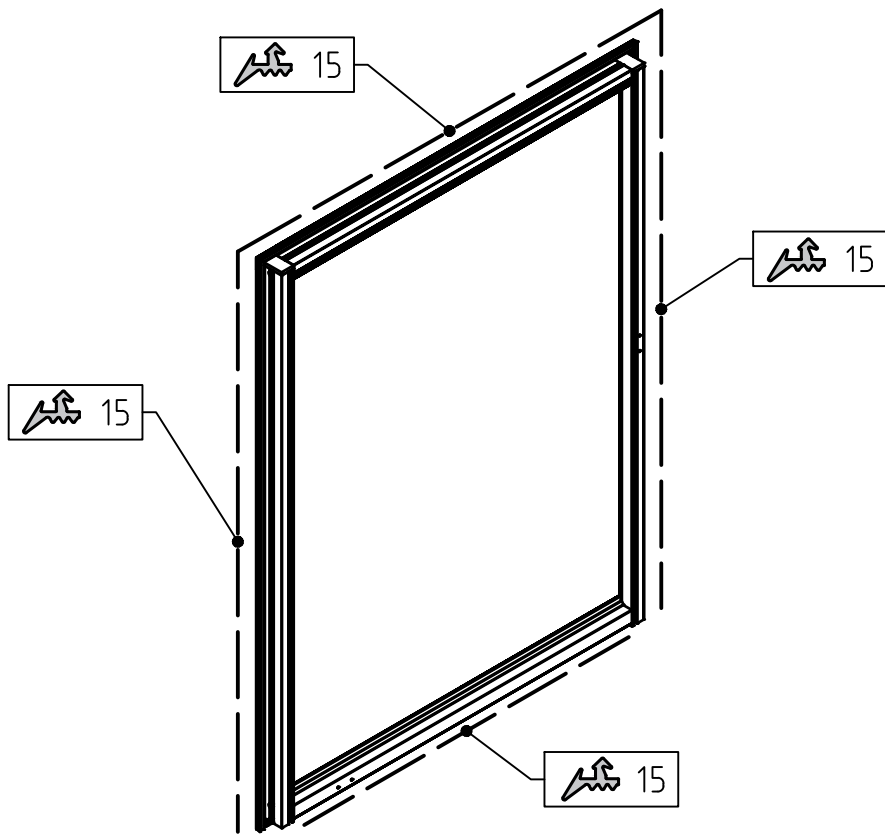

4x

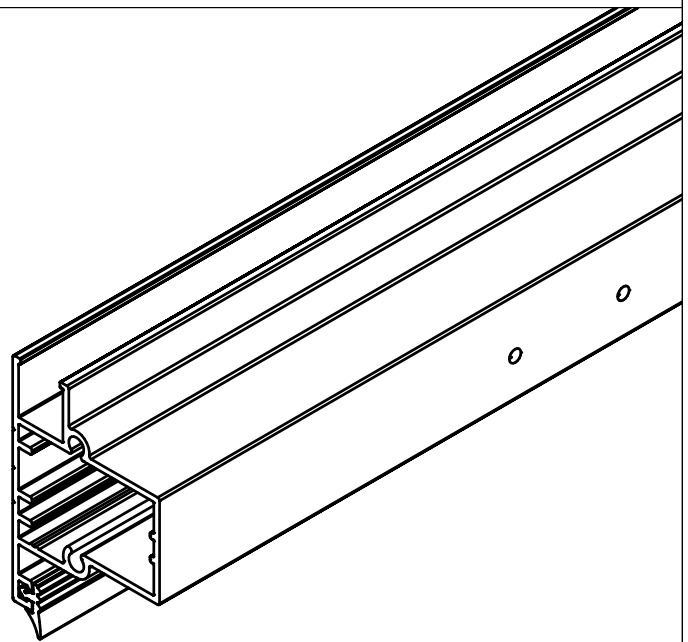
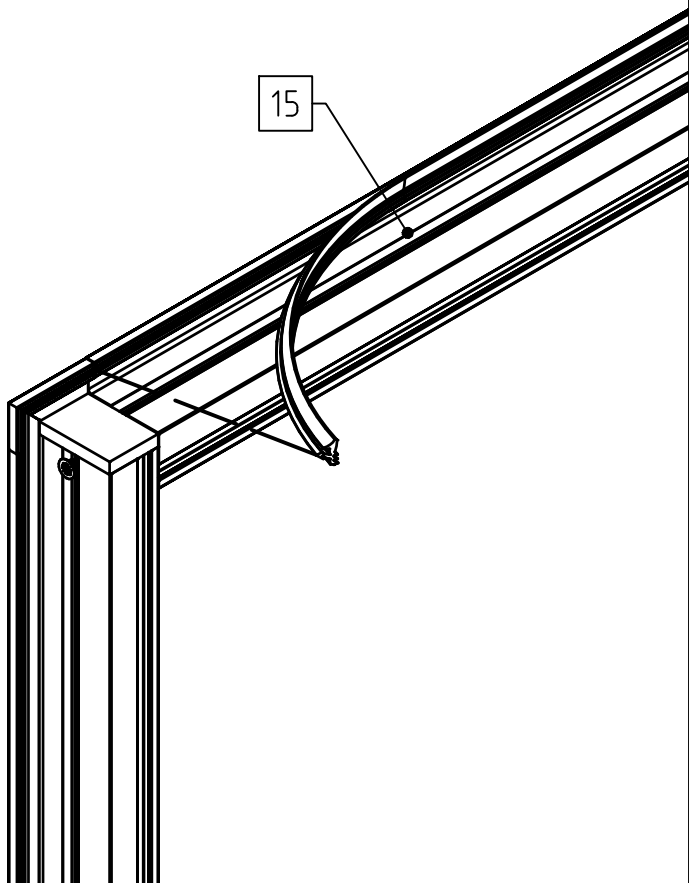

VD

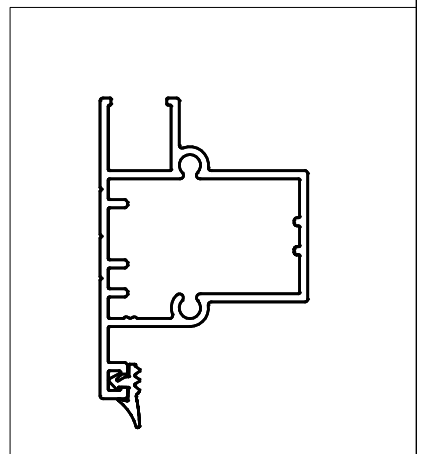

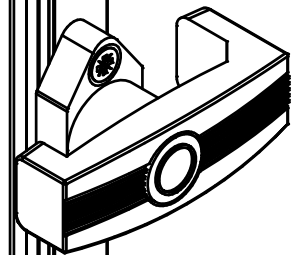
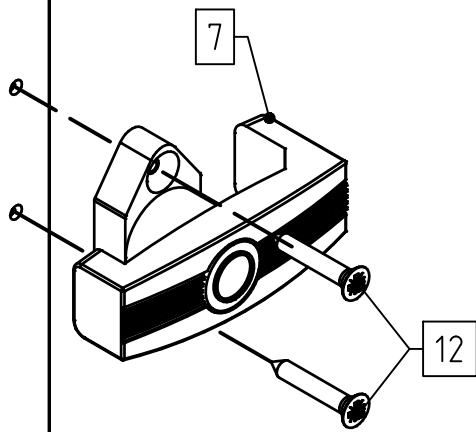
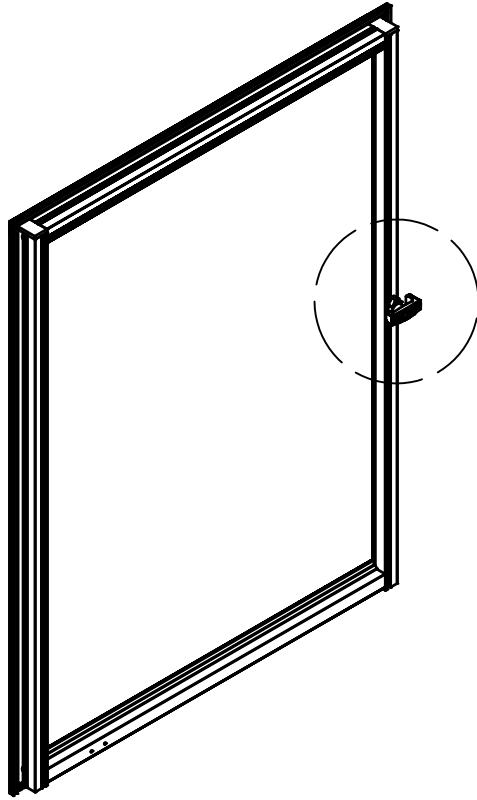

A

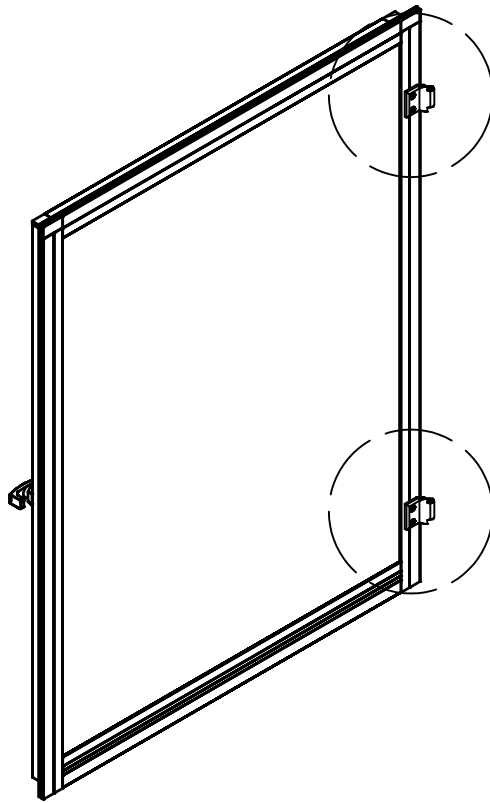

2x

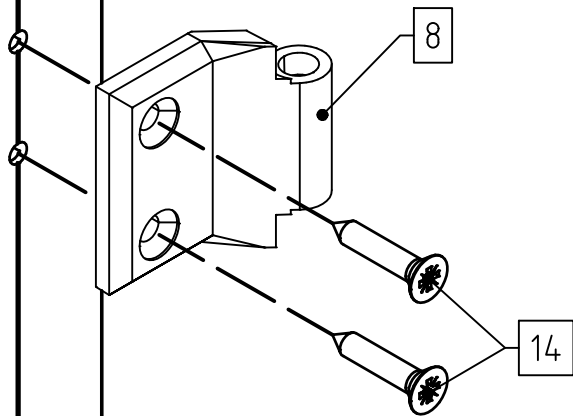

2x

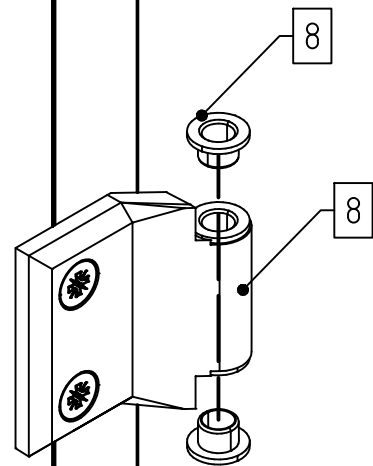

L



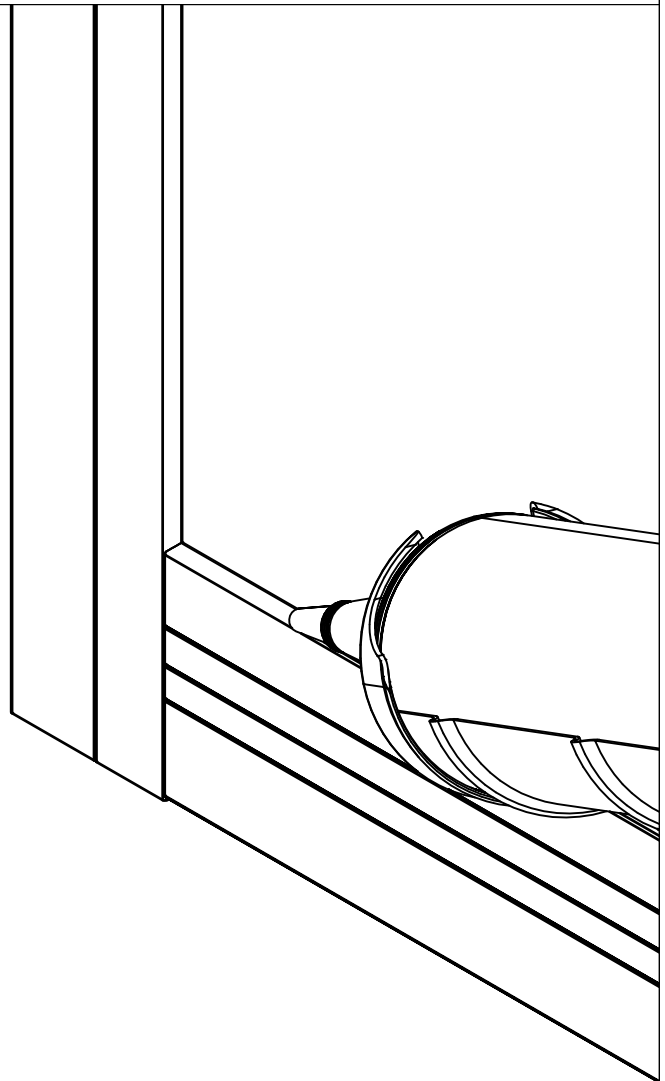
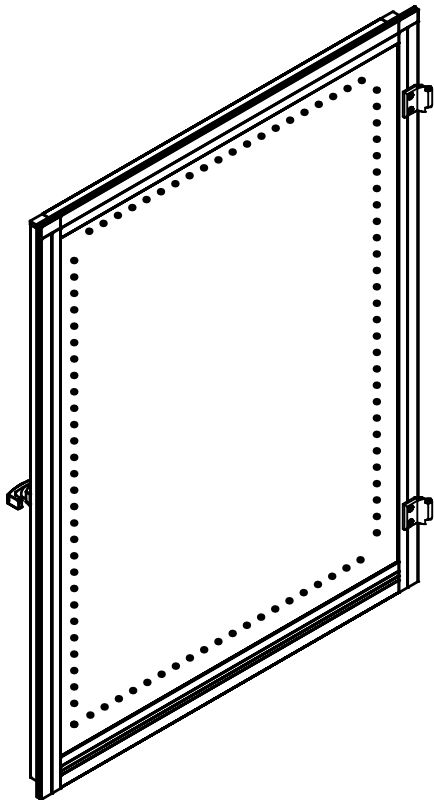
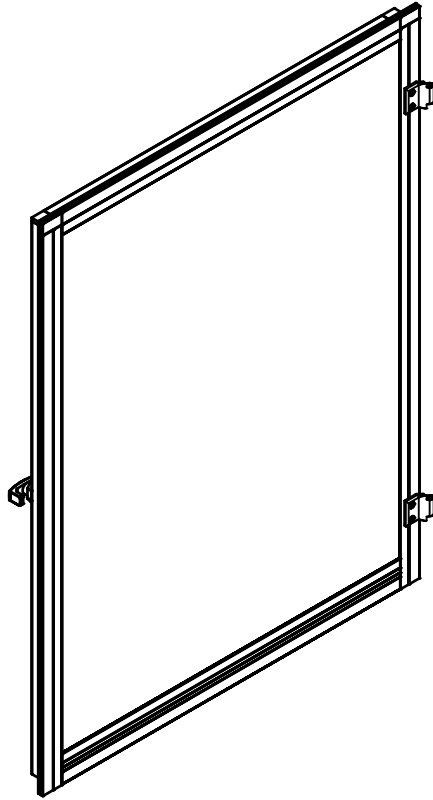
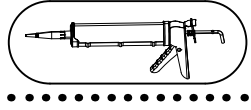

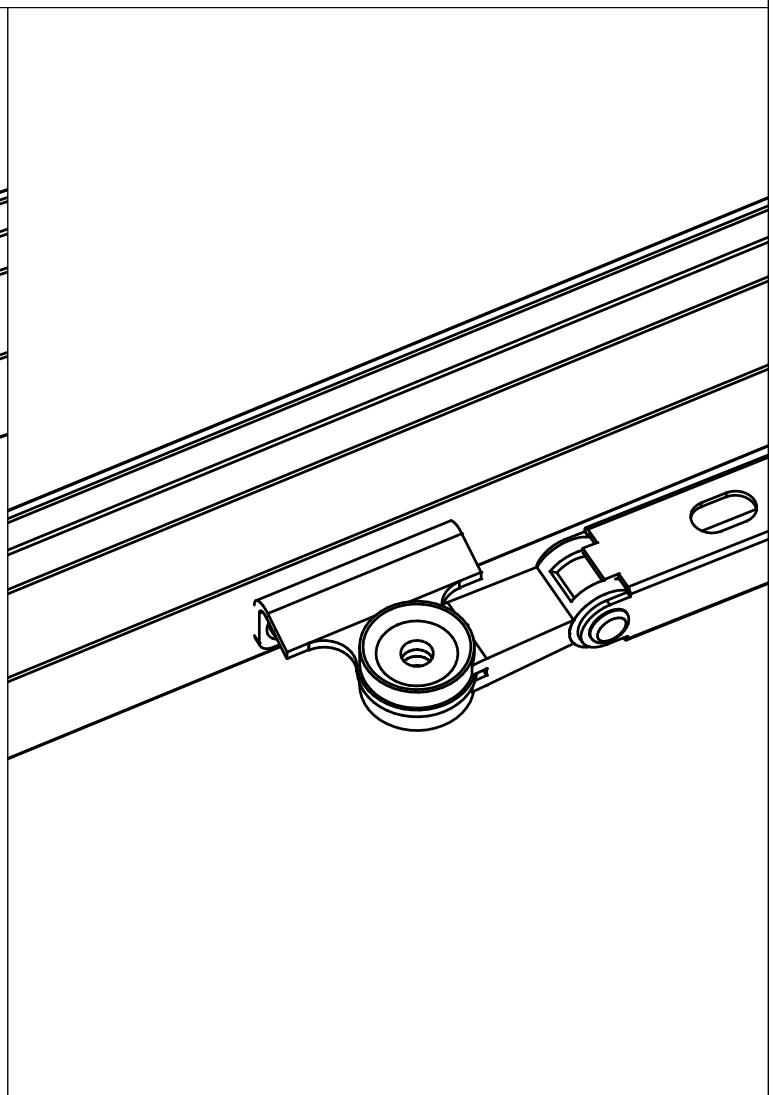
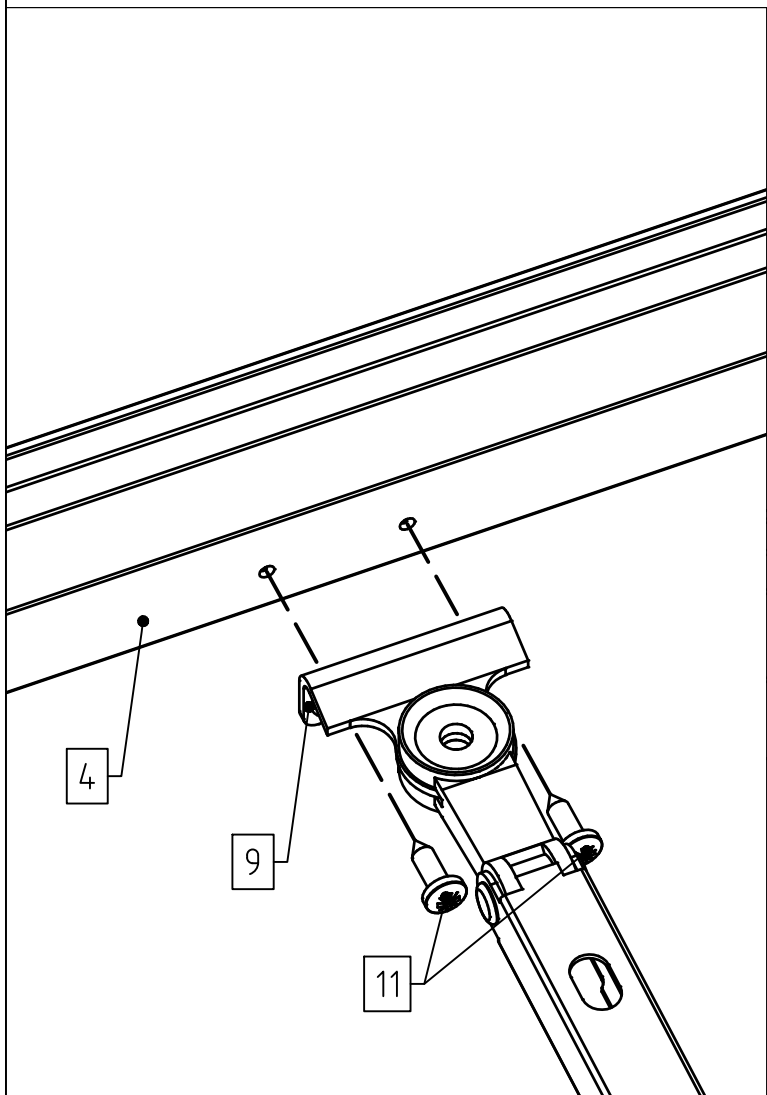
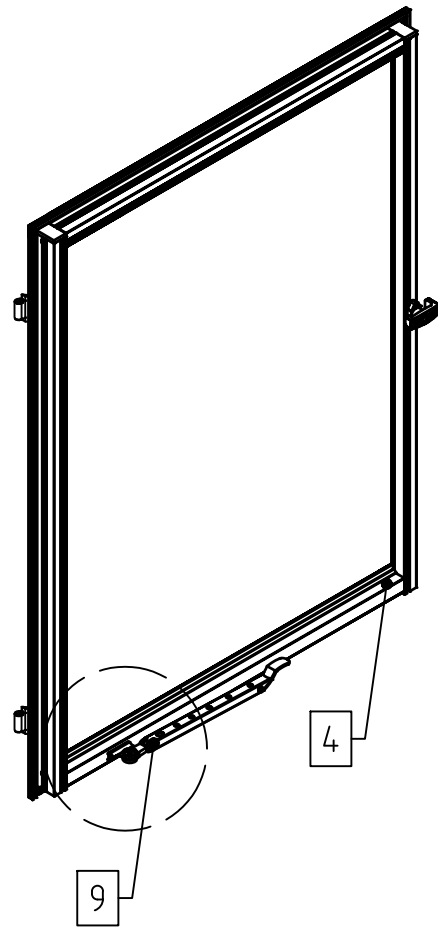
A





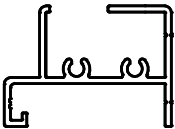
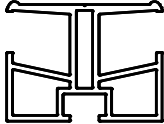
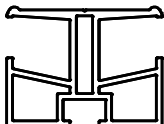
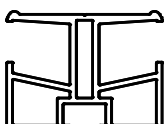
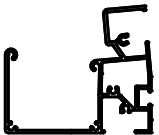
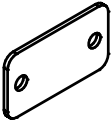
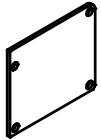
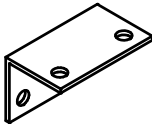

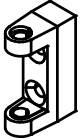
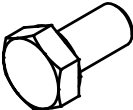
STÜCKLISTE

Rückwandgiebel Linea I

Pos.	Abbildung	Art.-Nr.	Bezeichnung	Anzahl	Bemerkung
1		P063-18-01-00-04-1	Bodenprofil 10 mm	1	2238 mm
2		P077-50-01-00-04-1	Mittelsprosse 10mm inkl. Kunststoffgleiter (links)	1	1895 mm
3		P077-51-01-00-04-1	Mittelsprosse 10mm inkl. Kunststoffgleiter (rechts/Scharniere)	1	1895 mm
4		P077-03-01-00-04-1	Mittelsprosse 10mm (Querriegel)	2	758 mm
5		P057-02-01-00-04-1	Rinnenprofil	1	2243 mm
6		9999000031	Verbindungsplatte (55 x 30 mm)	4	
7		9999000422	Rinnenenddeckel	2	
8		9999000416	Halter für Handaufsteller	1	50 mm
9		9999000615	Fixierdorn	1	
10		9999000358	Scharnierunterteil	2	
11		9999000124	Sechskantschraube M6 x 12	12	DIN 933
12		9999000128	Sechskantschraube M6	12	DIN 934

STÜCKLISTE

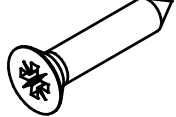
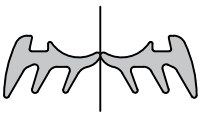
Rückwandgiebel Linea I

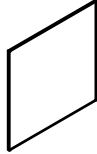
Pos.	Abbildung	Art.-Nr.	Bezeichnung	Anzahl	Bemerkung
13		9999000144	Linsenkopfschraube 4,2 x 13	10	DIN 7981
14		9999000163	Senkkopfschraube 4,8 x 25	4	DIN 7982
15		9999000119	Keildichtung 3-5 mm	1x 0,76m 2x 0,72m	mittig auseinander ziehen
16			PC-Hohlkammerplatte 730 x 1946 mm	2	
17			PC-Hohlkammerplatte 787 x 776 mm	1	
18					
19					
20					
21					
22					
23					
24					

1

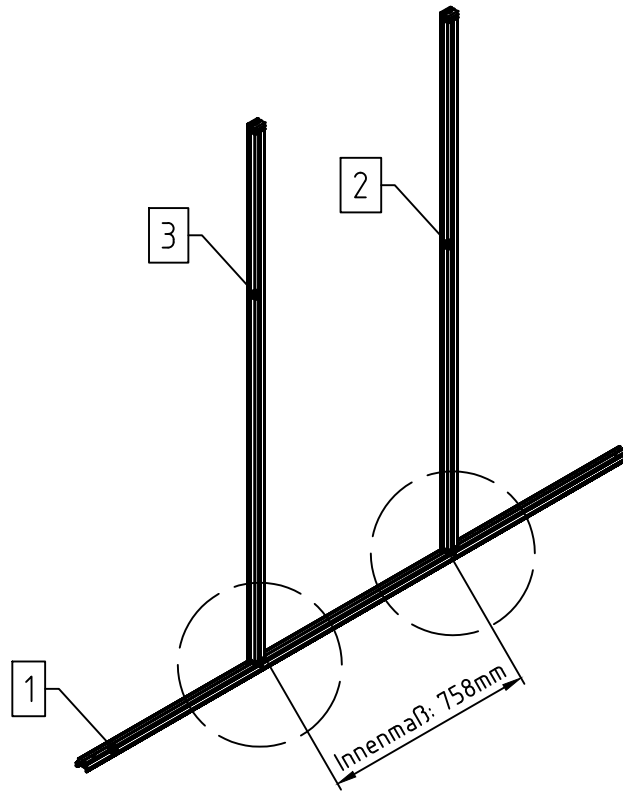

2x

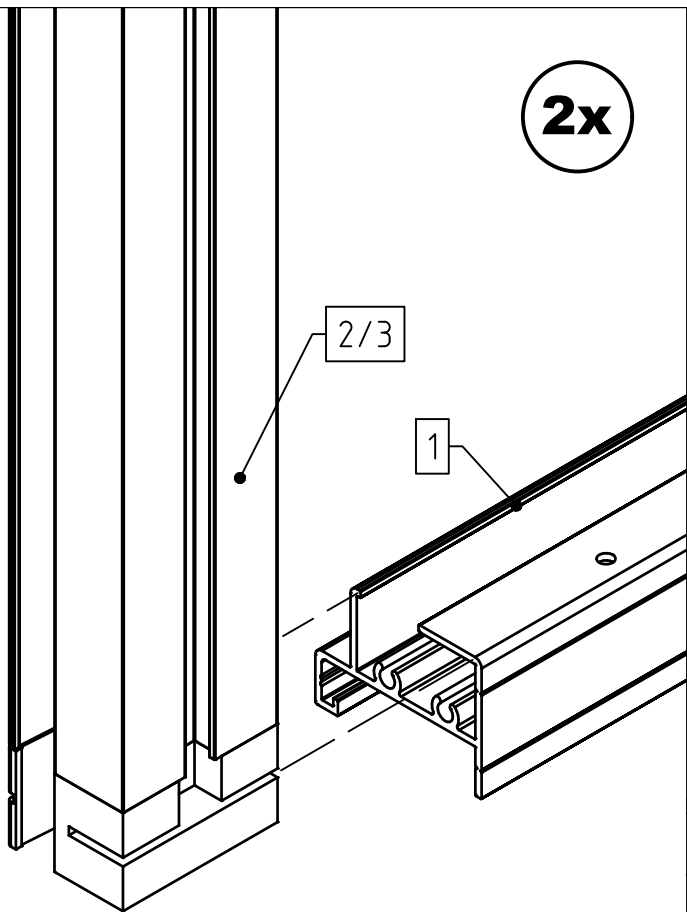

2x

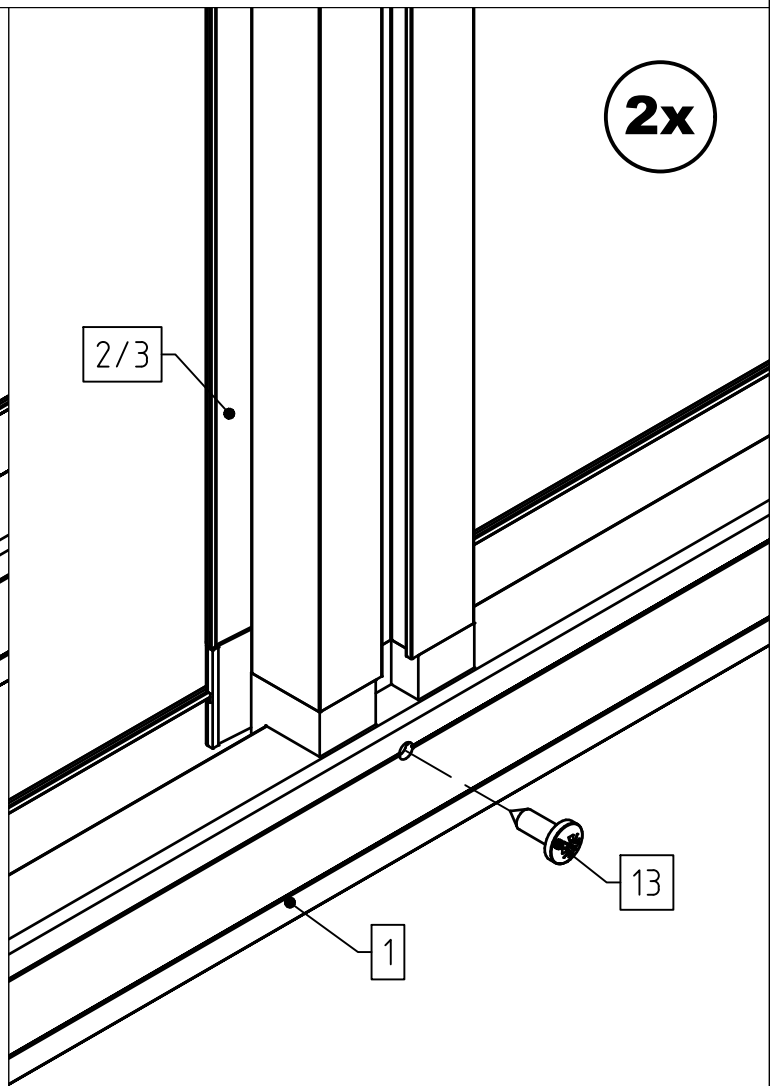

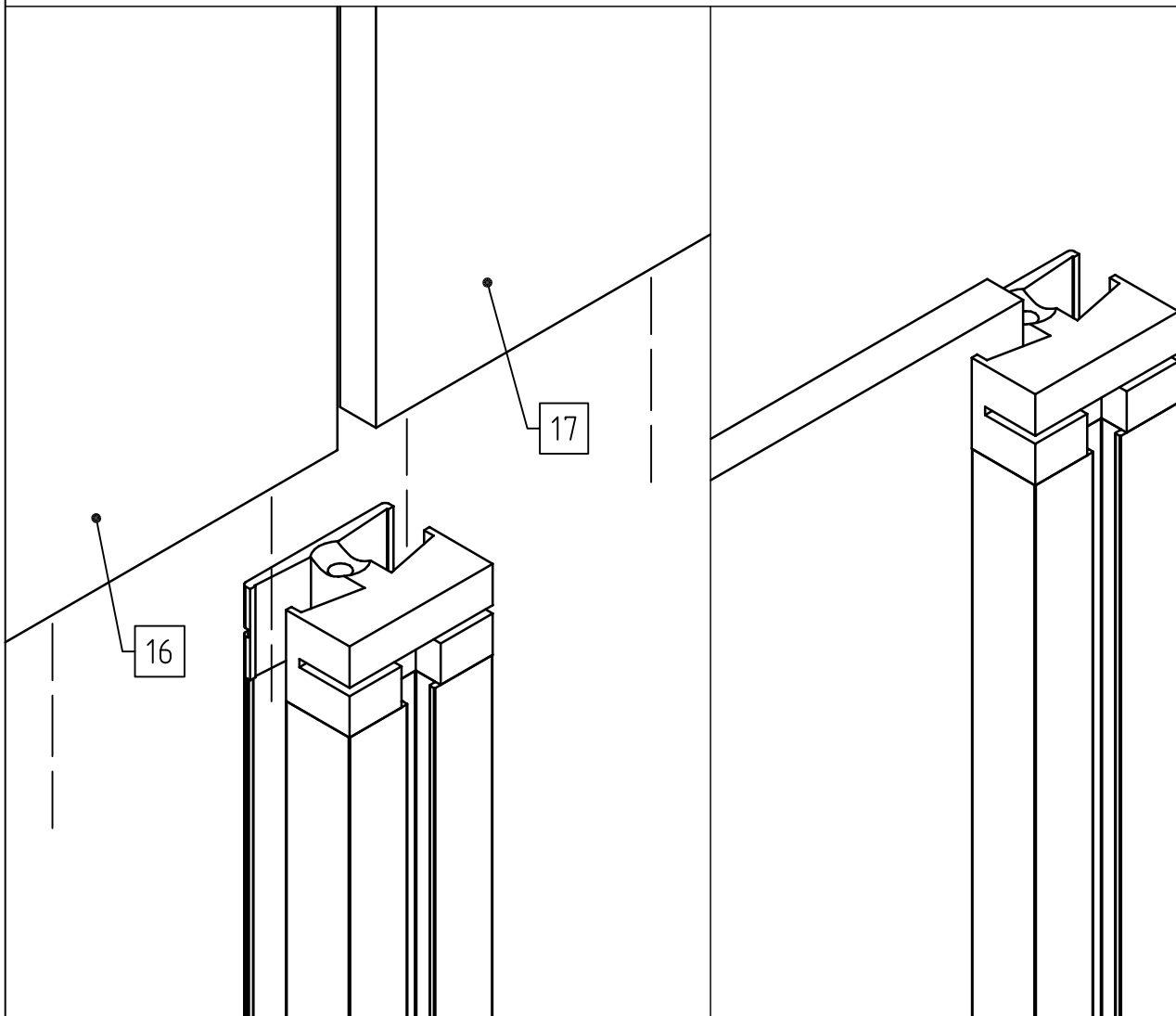
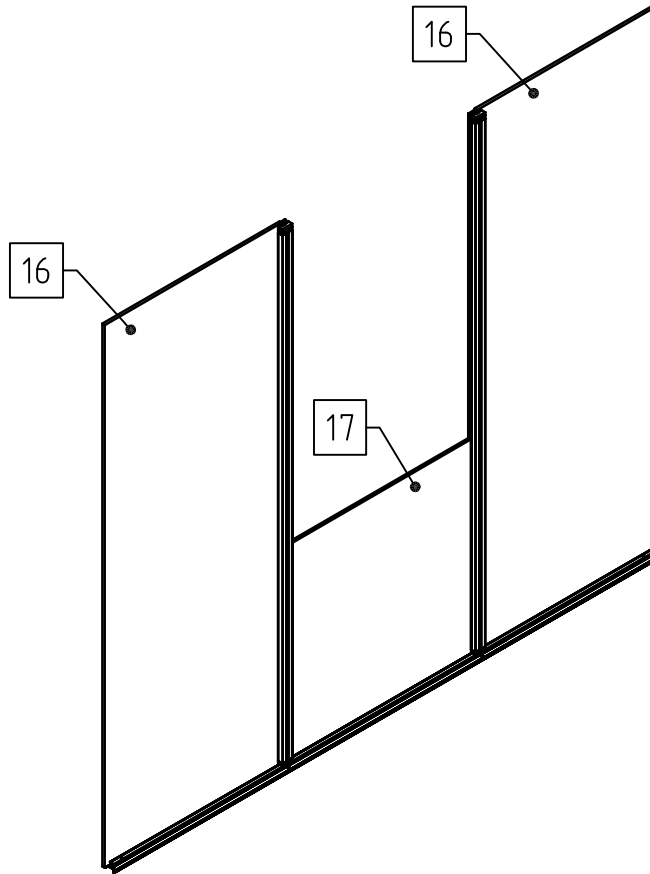

1

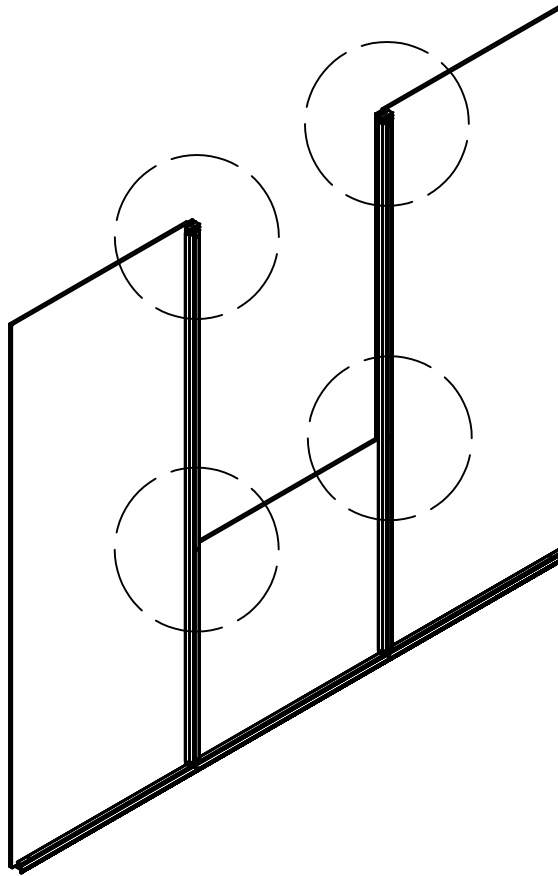

2x

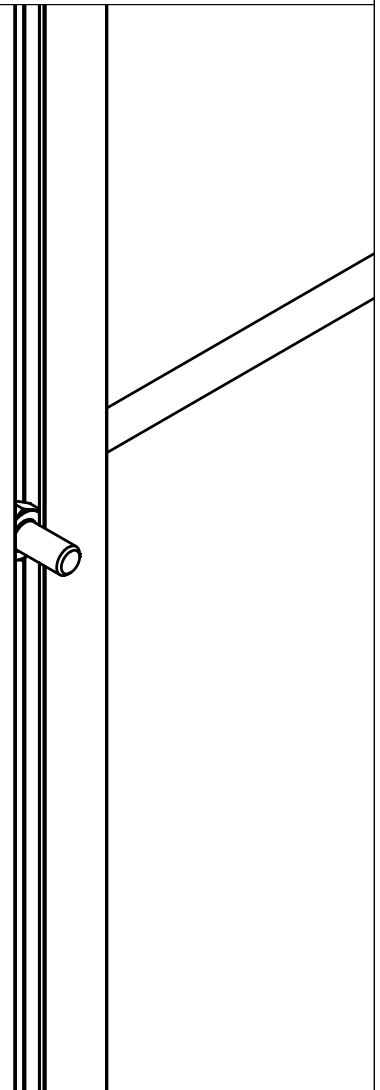
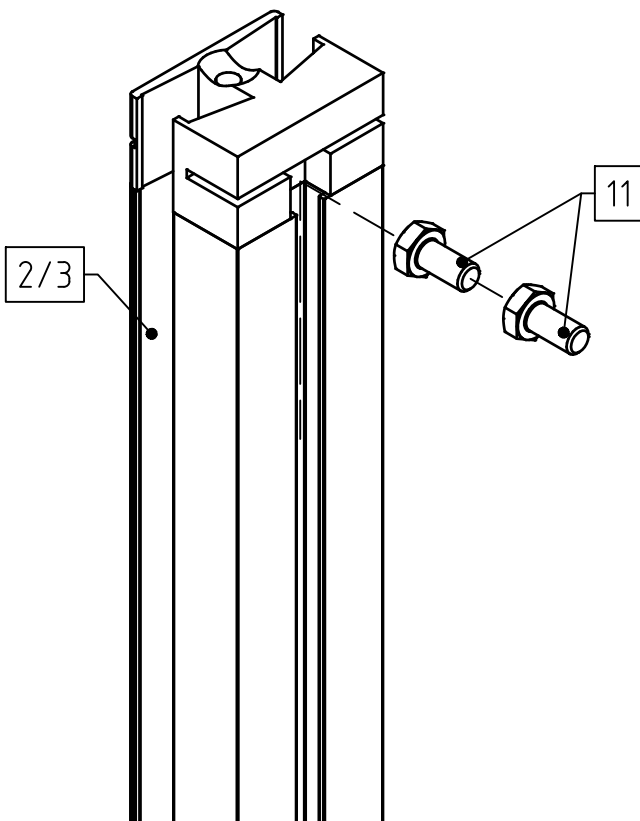

1

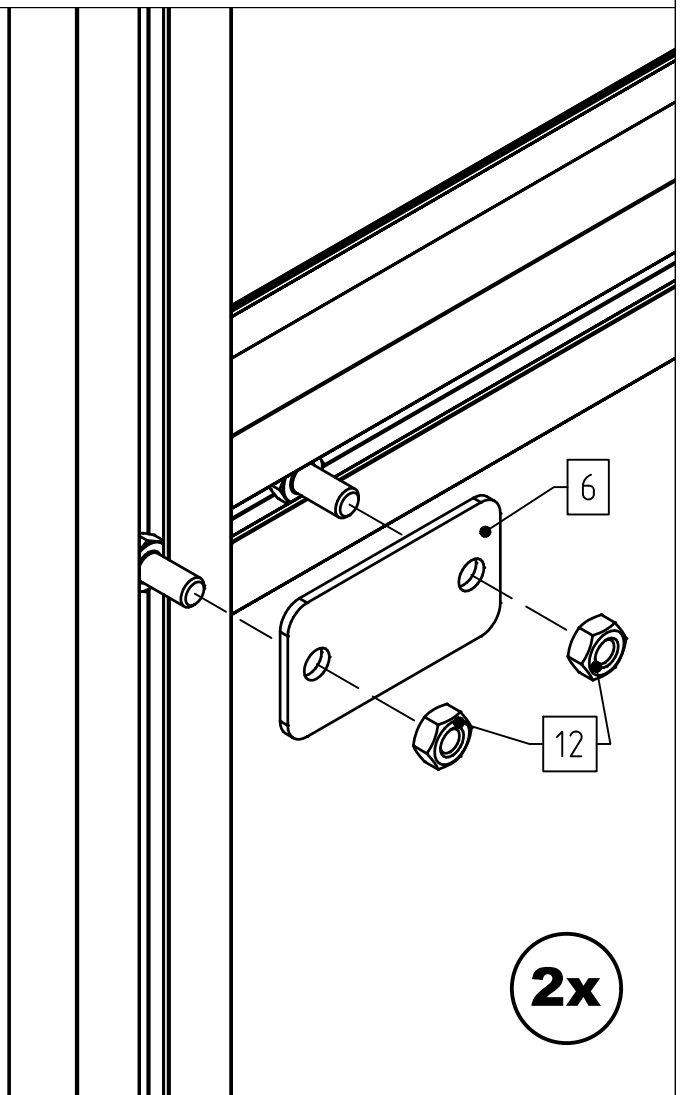
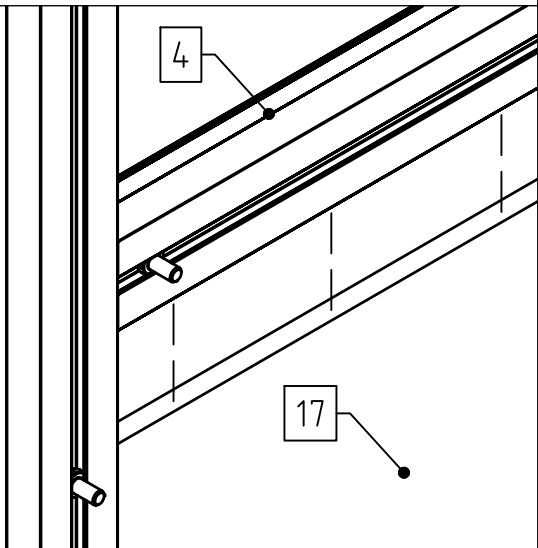
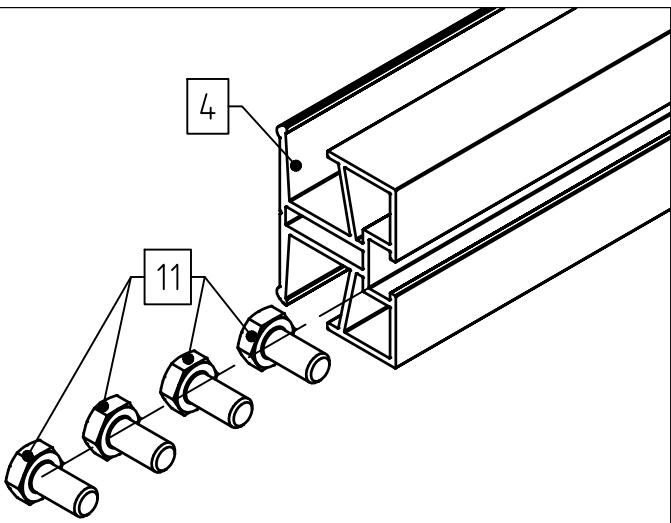
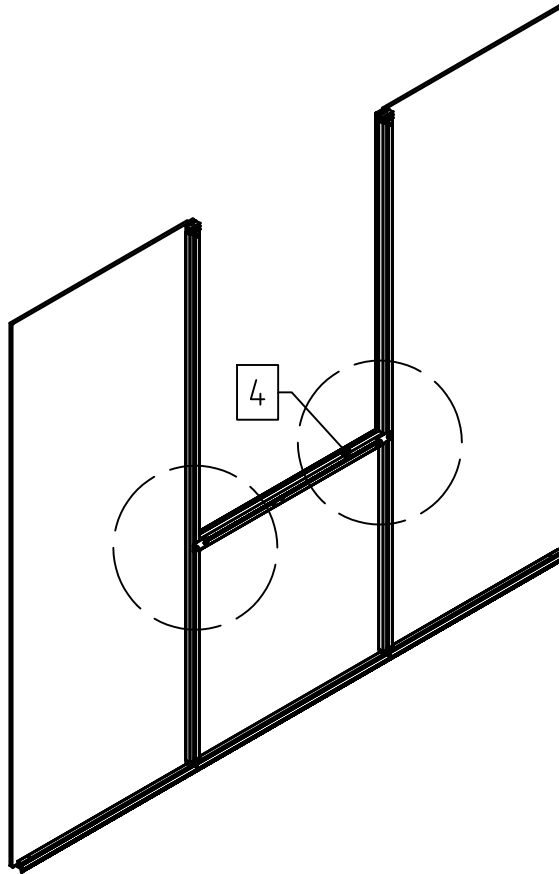

2x

1

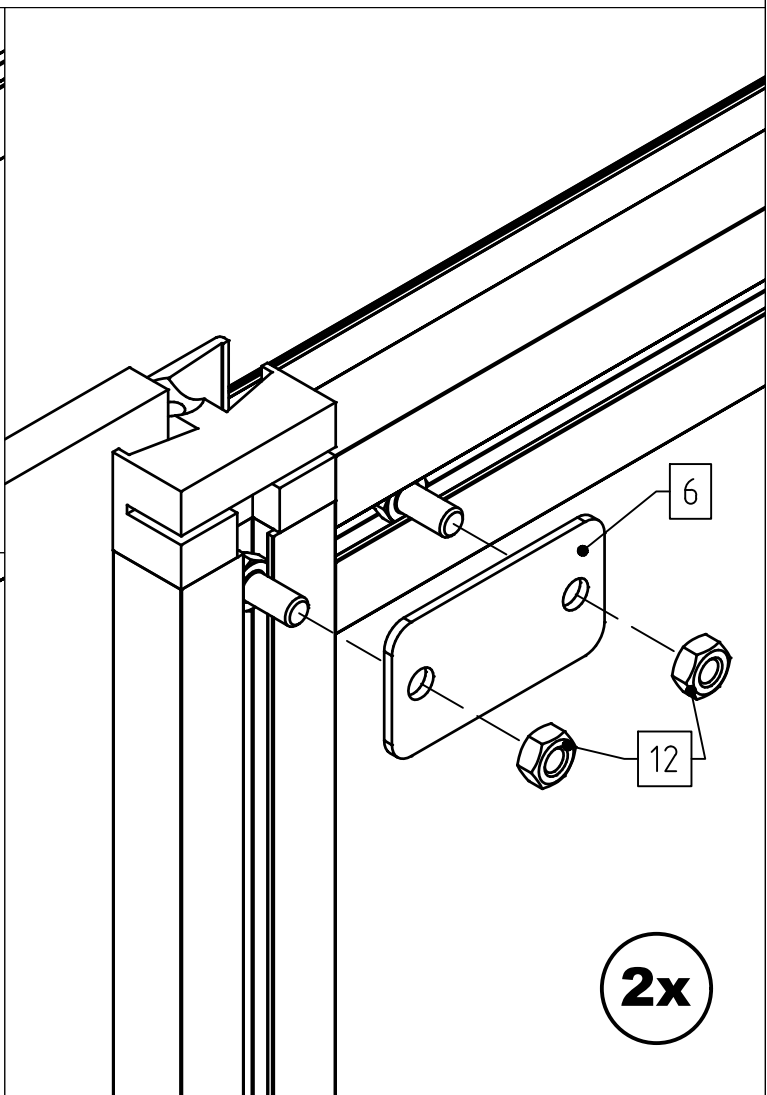
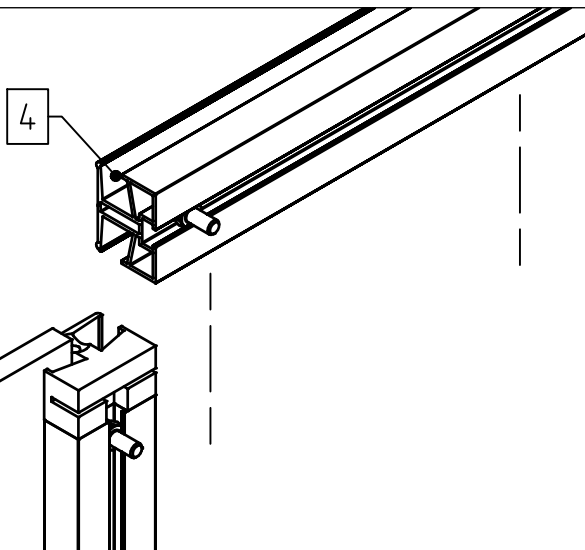
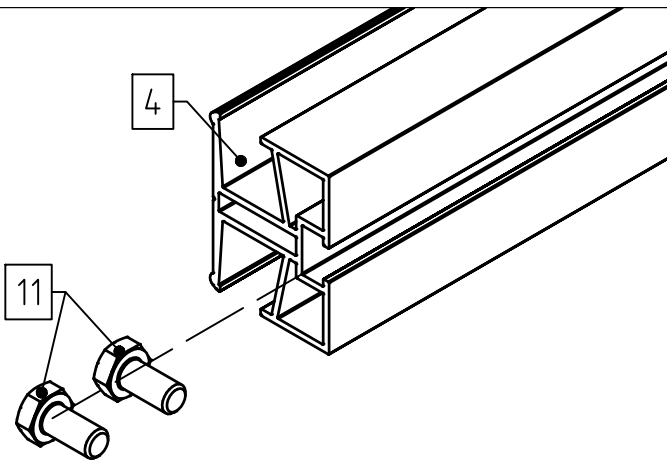
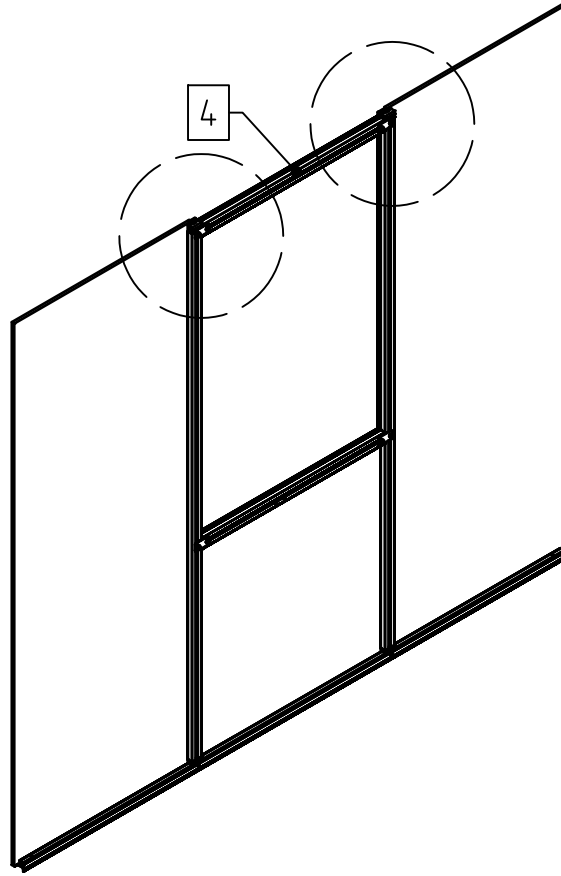

1

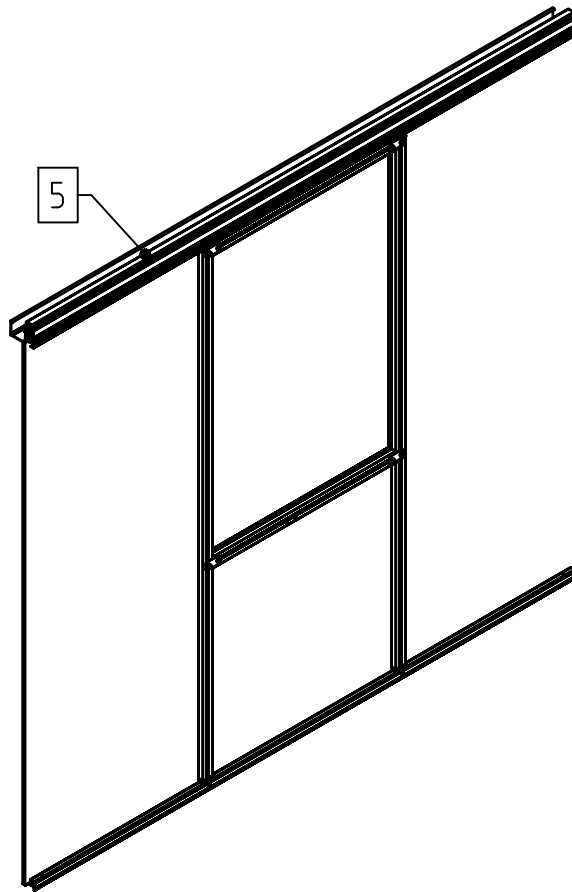

5

aufschieben!

2/3

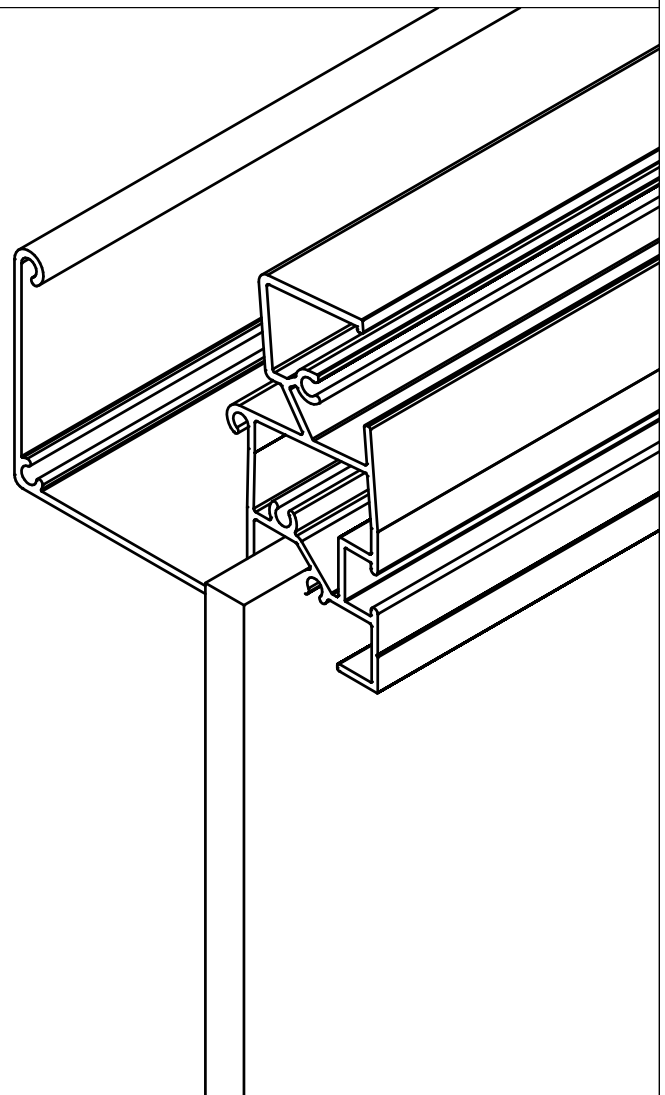
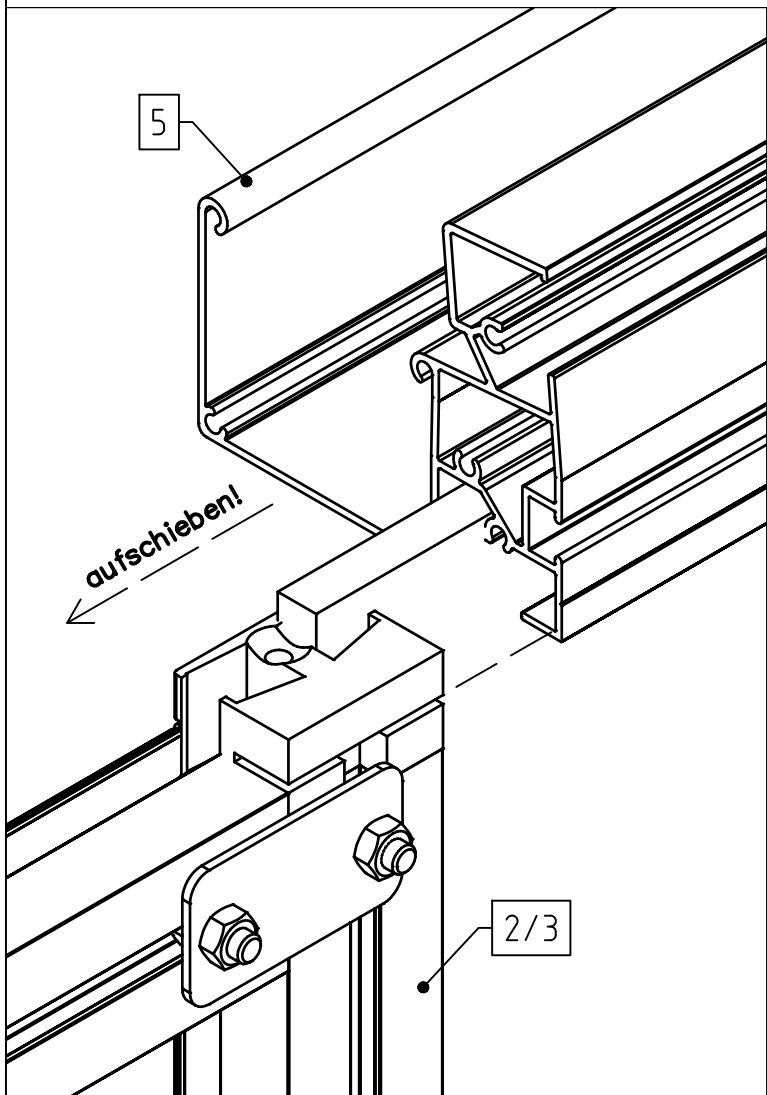

1

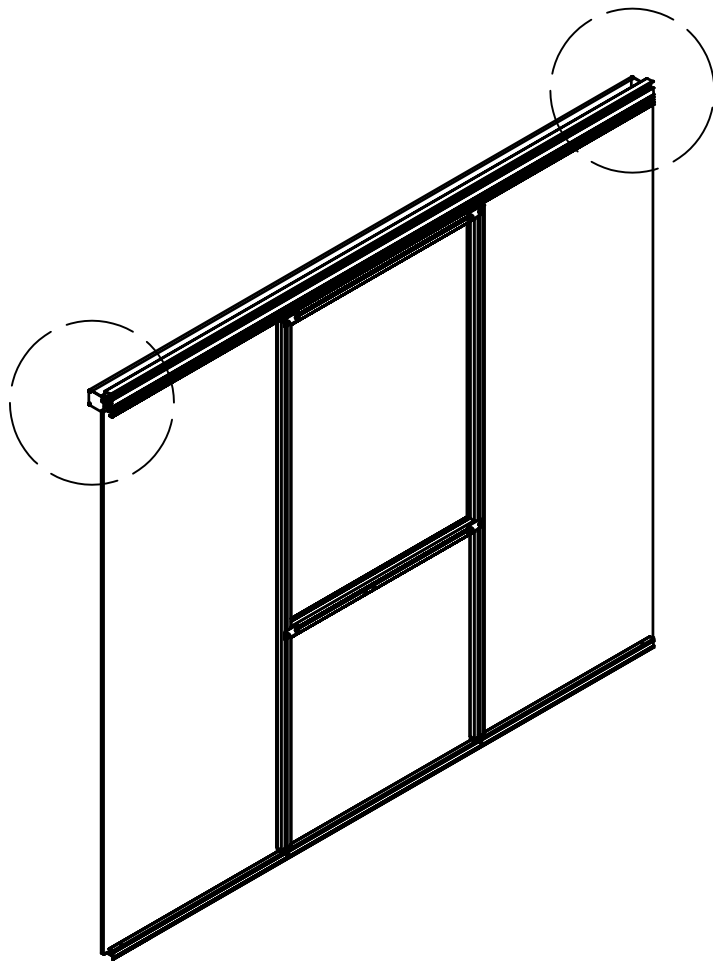

2x

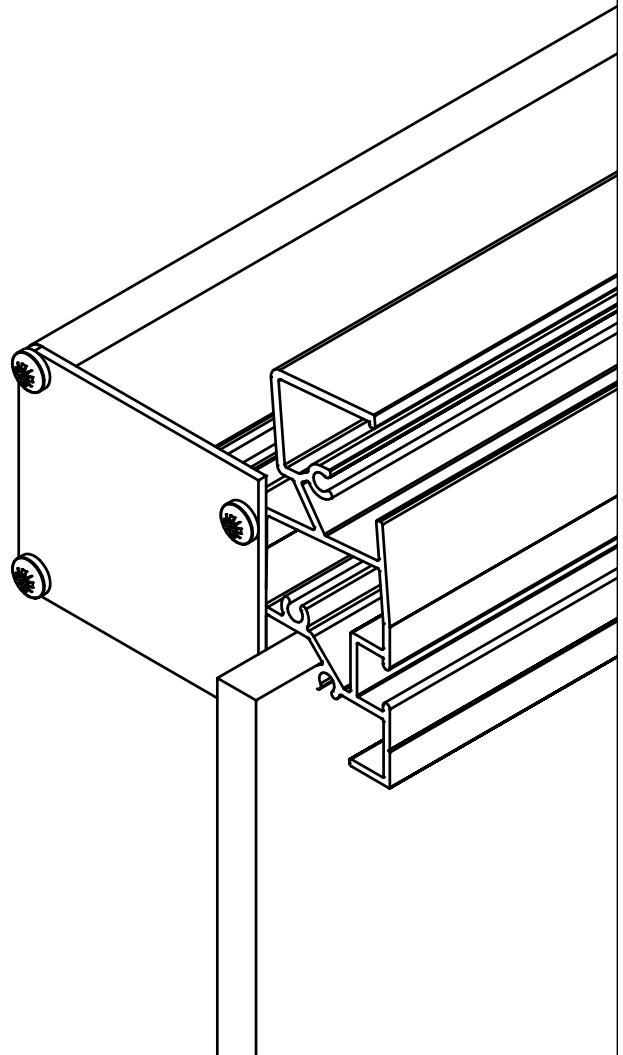
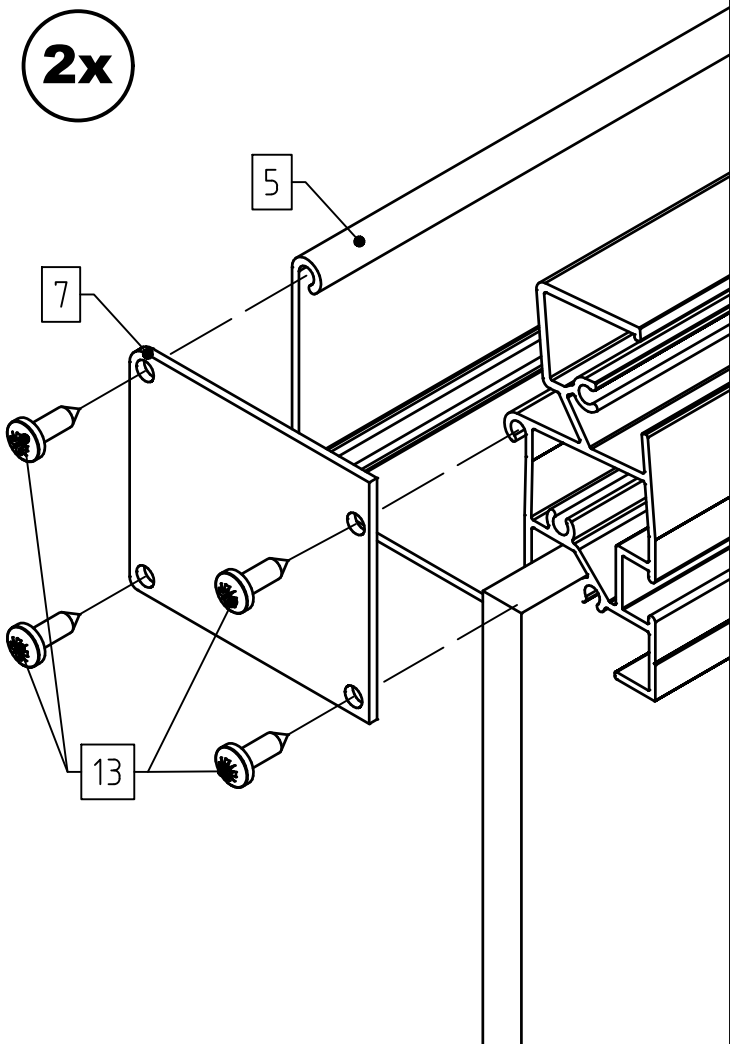

1

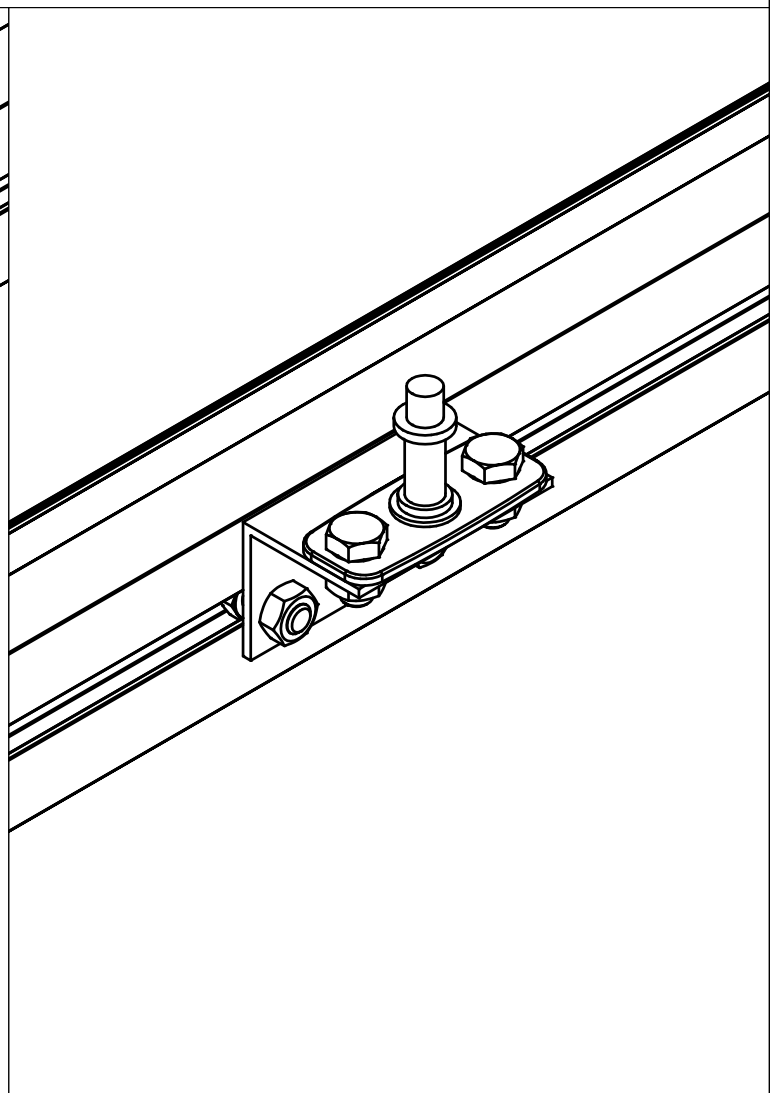
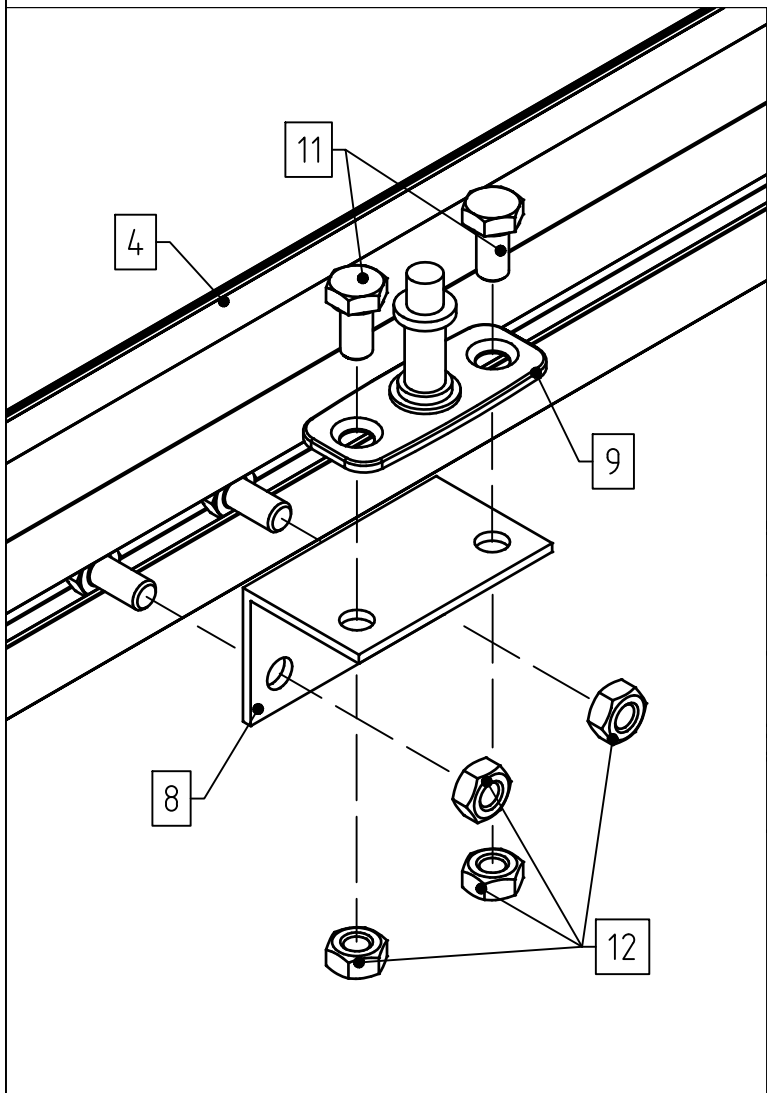
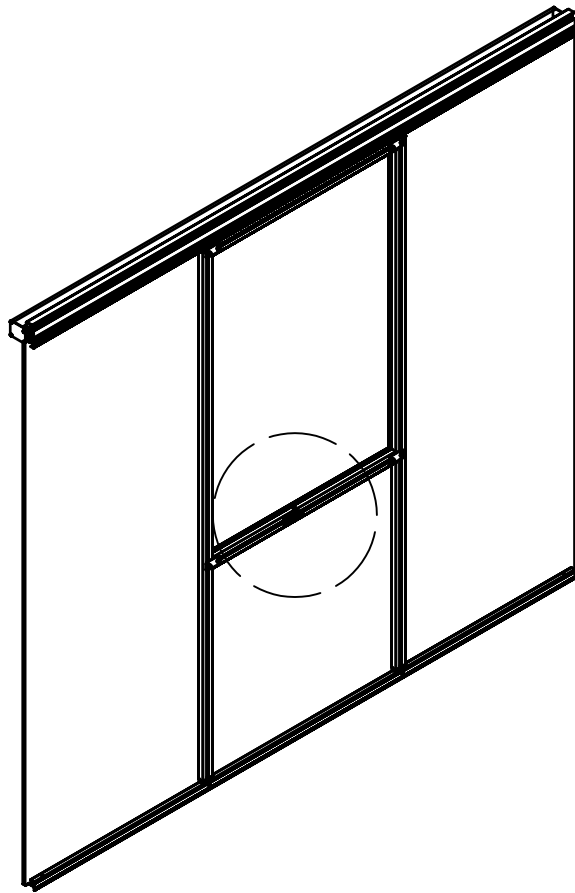

A

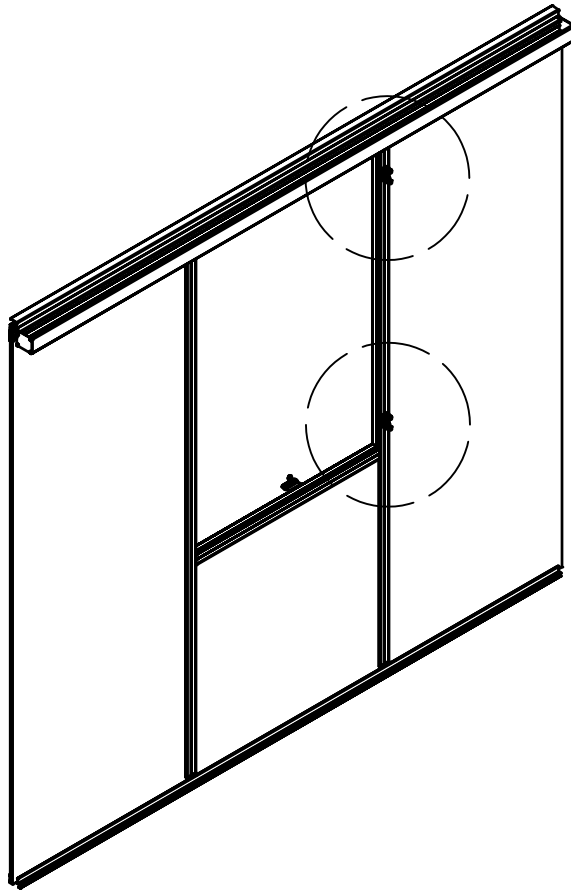

2x

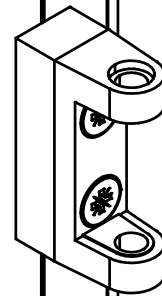
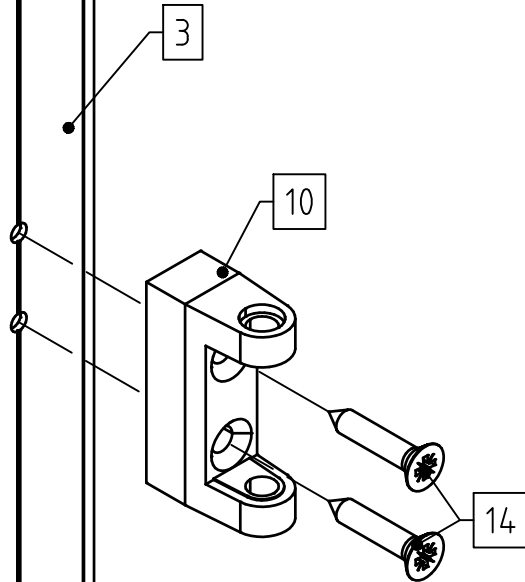

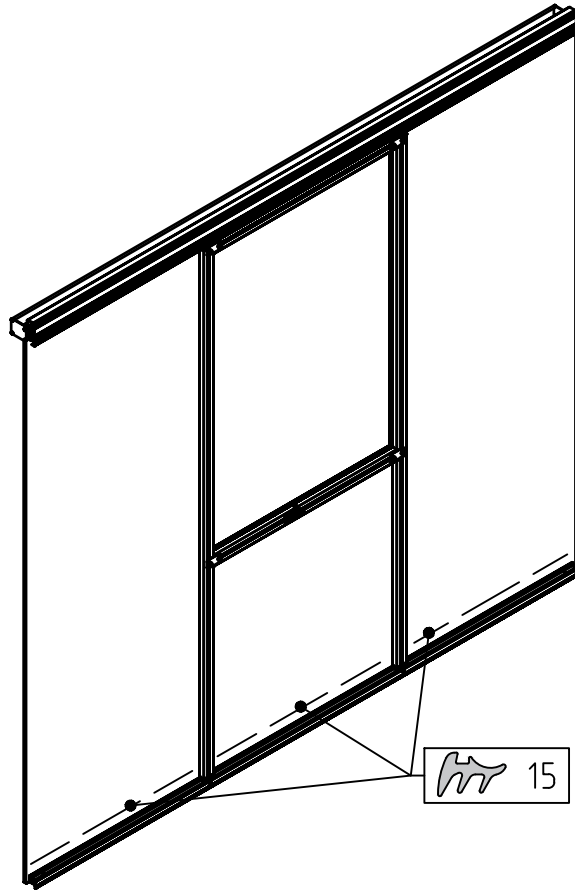

3x



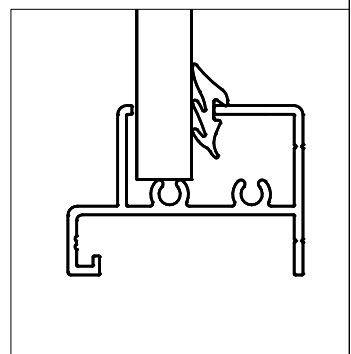

15

VD



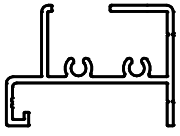
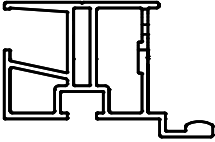
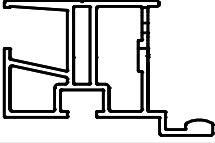
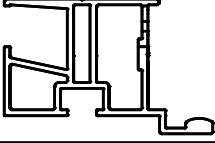
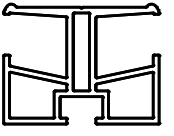
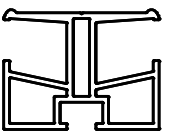
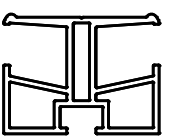



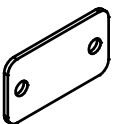

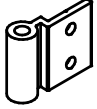

STÜCKLISTE

Türgiebel Linea I

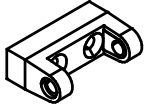
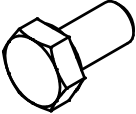
Pos.	Abbildung	Art.-Nr.	Bezeichnung	Anzahl	Bemerkung
1		P063-18-01-00-04-1	Bodenprofil 10 mm	1	2238 mm
2		P060-08-01-00-04-1	Zargenprofil 10 mm (links von außen, Schloss)	1	2028 mm
3		P060-09-01-00-04-1	Zargenprofil 10 mm (rechts von außen, Scharnier)	1	2028 mm
4		P060-10-01-00-04-1	Zargenprofil 10 mm (oben)	1	758 mm
5		P077-05-01-00-04-1	Mittelsprosse 10 mm (Querriegel links)	1	702 mm
6		P077-05-01-00-04-1	Mittelsprosse 10 mm (Querriegel rechts)	1	702 mm
7		P077-52-01-00-04-1	Mittelsprosse 10 mm (Querriegel oben)	1	2243 mm
8		P042-05-01-00-00-1	Distanzleiste 10 mm (links & rechts)	2	702 mm
9		P042-06-01-00-00-1	Distanzleiste 10 mm (mitte)	1	758 mm
10		P091-02-01-00-04-1	U-Abschlussprofil 10 mm	2	151 mm
11		P062-01-01-00-04-1	Türanschlagprofil (Boden)	1	762 mm
12		9999000031	Verbindungsplatte 55 x 30 x 2	2	

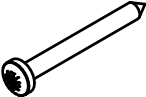

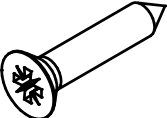
STÜCKLISTE

Türgiebel Linea I

Pos.	Abbildung	Art.-Nr.	Bezeichnung	Anzahl	Bemerkung
13		9999000660	Schließblech	1	
14		9999000716	Scharnier	4	30
15		9999000775	Türfeststellerblech	1	
16		9999000638	Magnet	1	Ø25 mm
17		9999000358	Scharnierunterteil	4	
18		9999000124	Sechskantschraube M6 x 12	10	DIN 933
19		9999000128	Sechskantmutter M6	5	DIN 934
20		9999000144	Linsenkopfschraube 4,2 x 13	10	DIN 7981
21		9999000150	Linsenkopfschraube 4,8 x 45	4	DIN 7981
22		9999000204	Senkkopfschraube 4,2 x 13	3	DIN 7982
23		9999000163	Senkkopfschraube 4,8 x 25	8	DIN 7982
24		9999000189	Bohrschraube mit Linsenkopf 3,5 x 13	2	DIN 7504

STÜCKLISTE

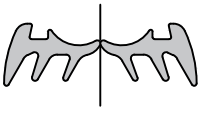
Türgiebel Linea I

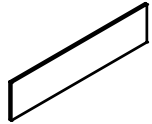
Pos.	Abbildung	Art.-Nr.	Bezeichnung	Anzahl	Bemerkung
25		9999000119	Keildichtung 3 – 5 mm	2x 0,72m	mittig auseinanderziehen!
26		9999002033	Ballondichtung 10 mm	2x 0,72m 1x 0,76m	
27			PC-Hohlkammerplatte 730 x 1850 mm	2	
28			PC-Hohlkammerplatte 178 x 740 mm	1	
29					
30					
31					
32					
33					
34					
35					
36					

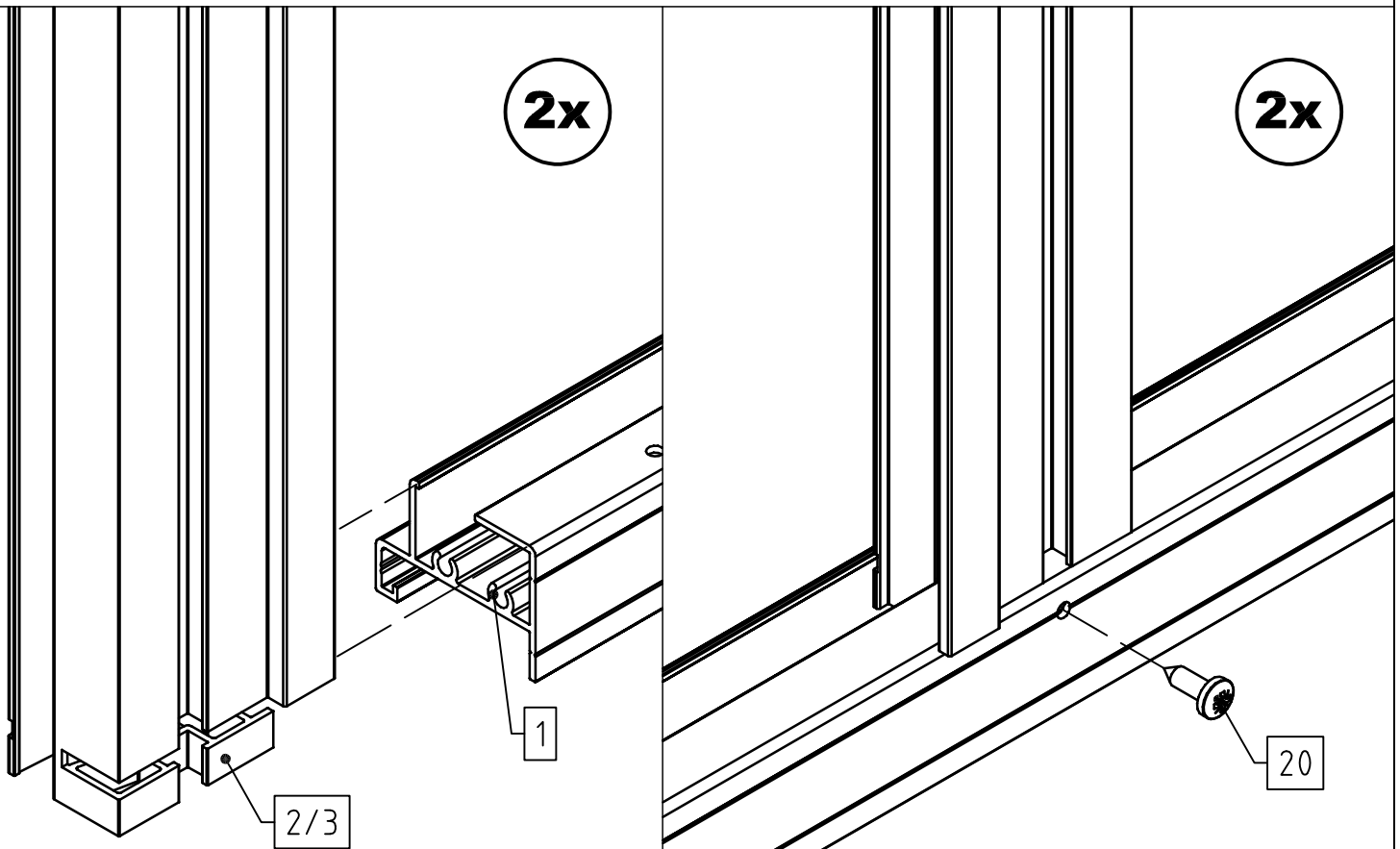
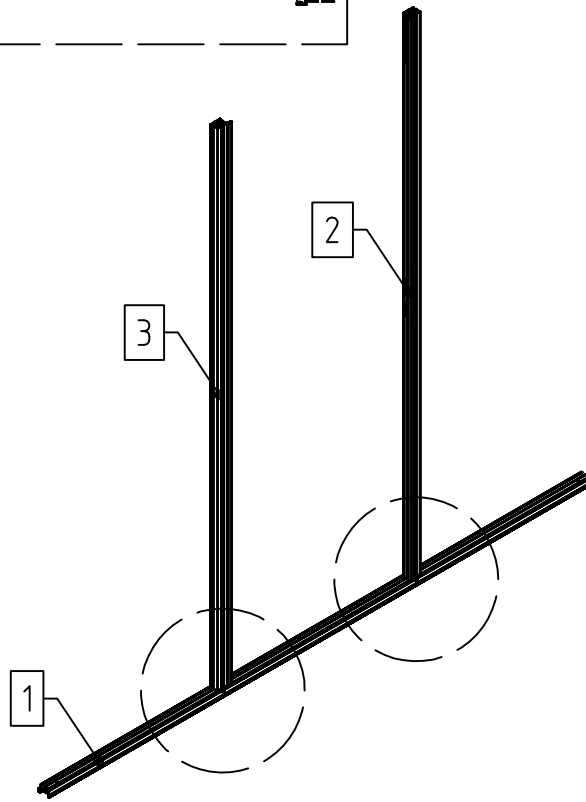
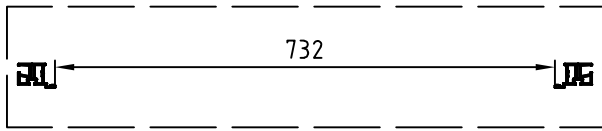

1

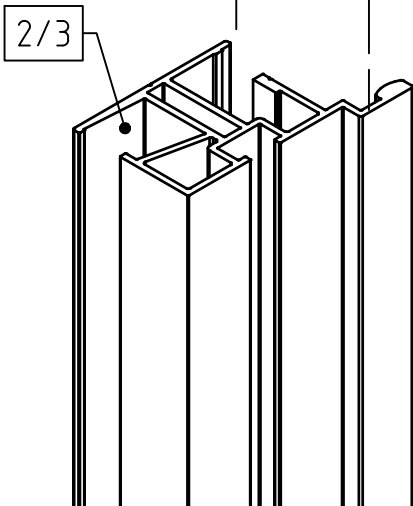
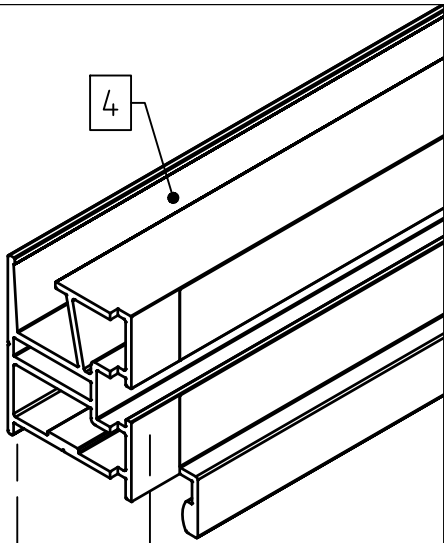
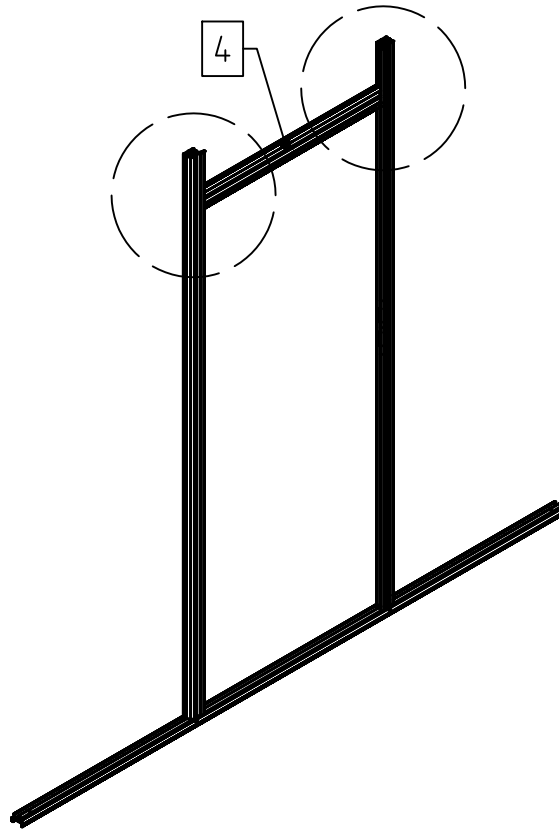

2x

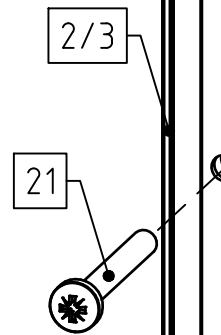

I

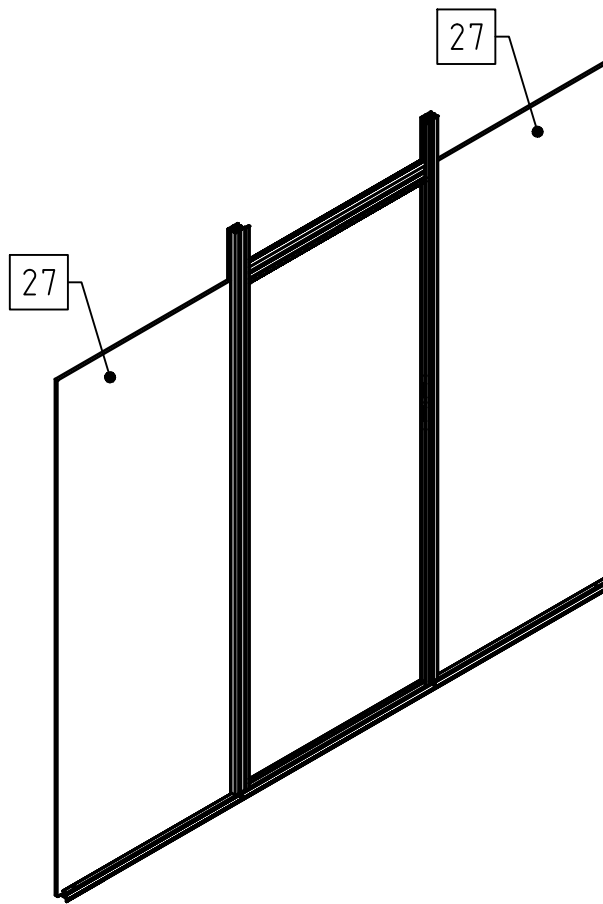

2x

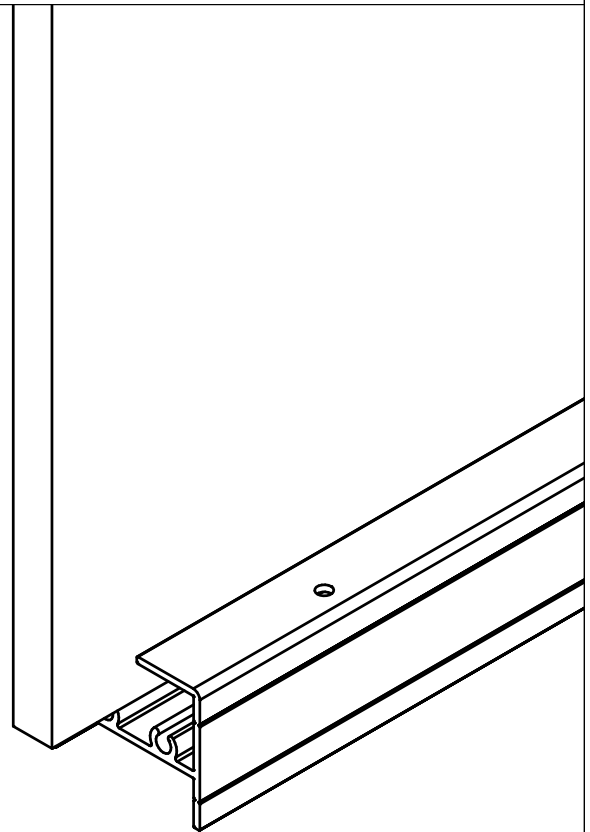
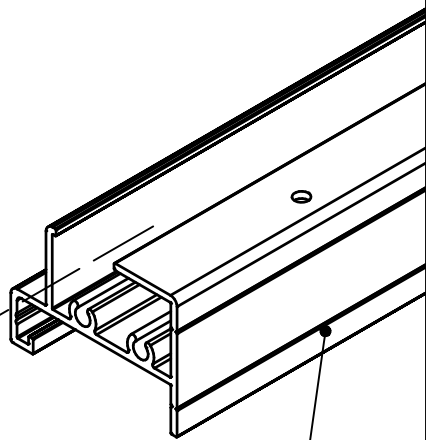

1

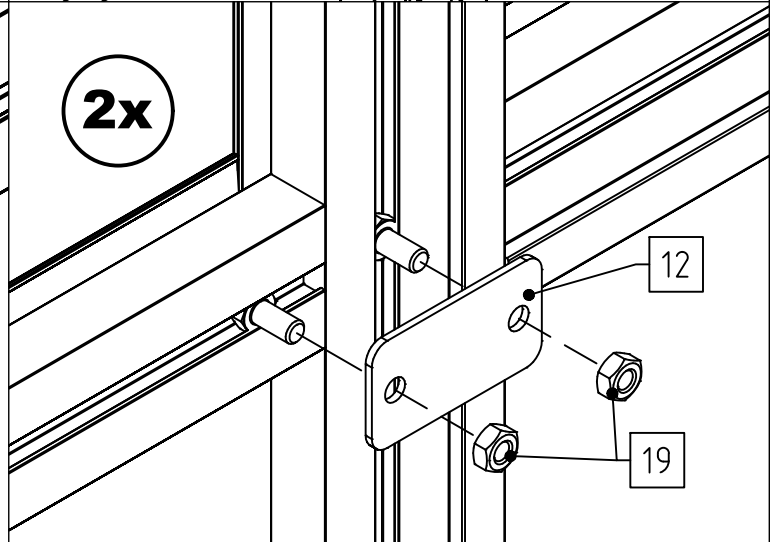
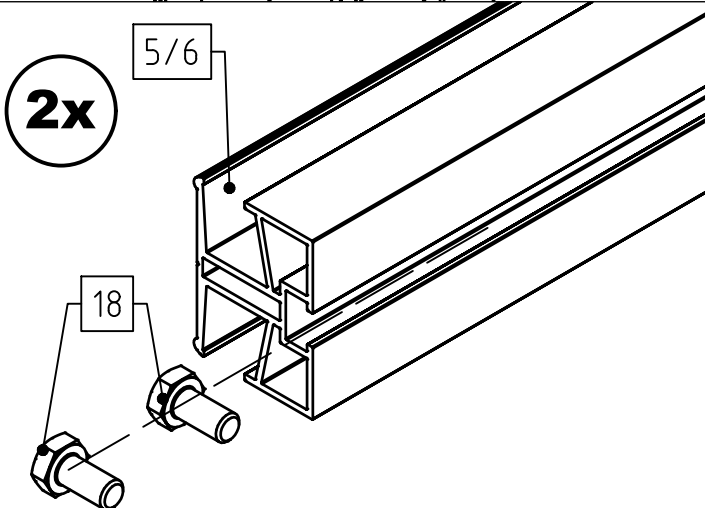
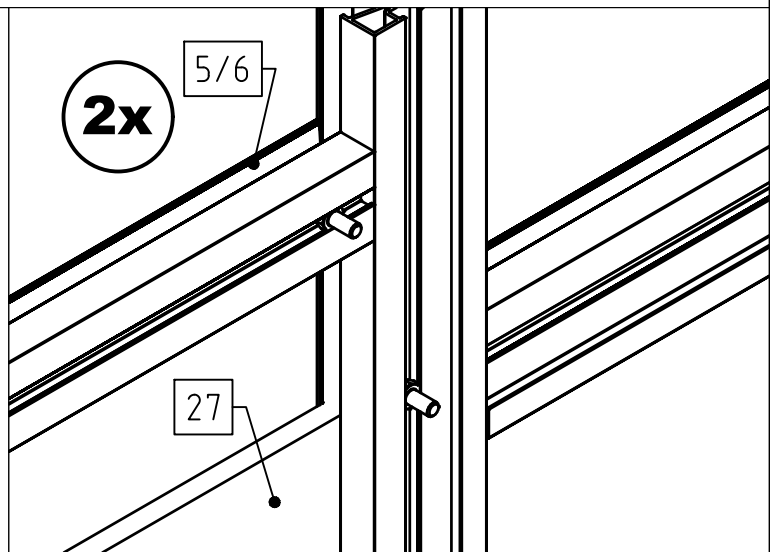
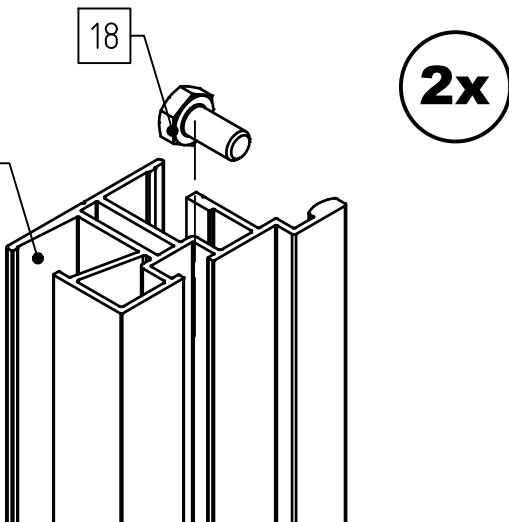
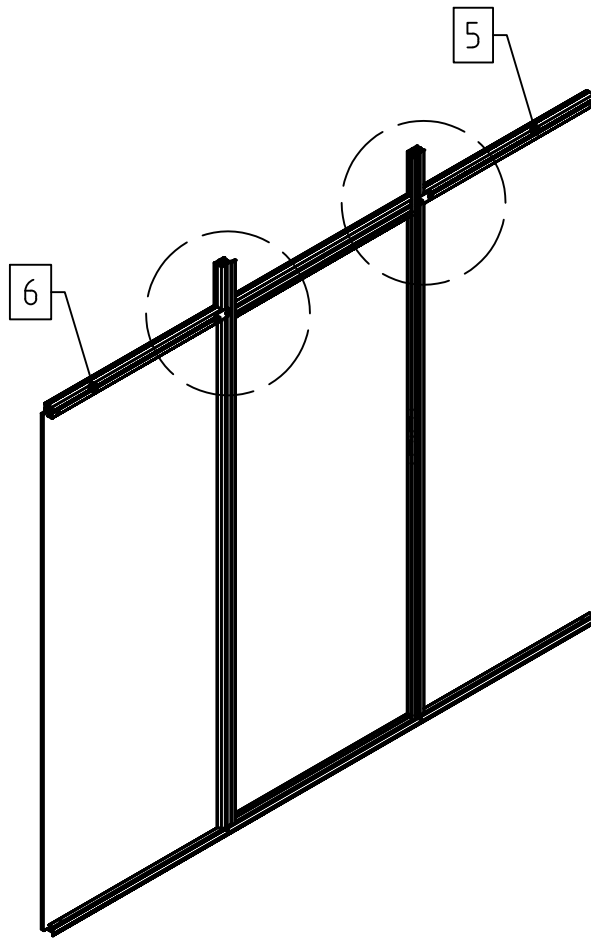

1

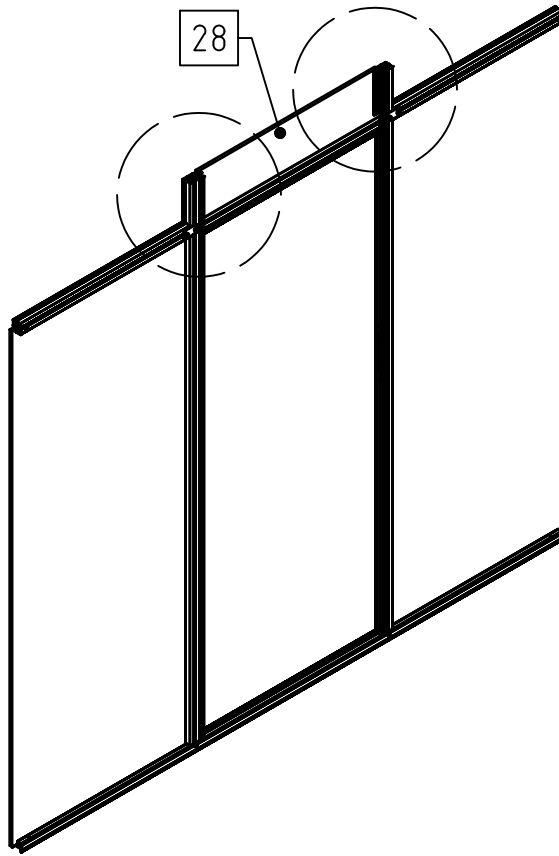

2x

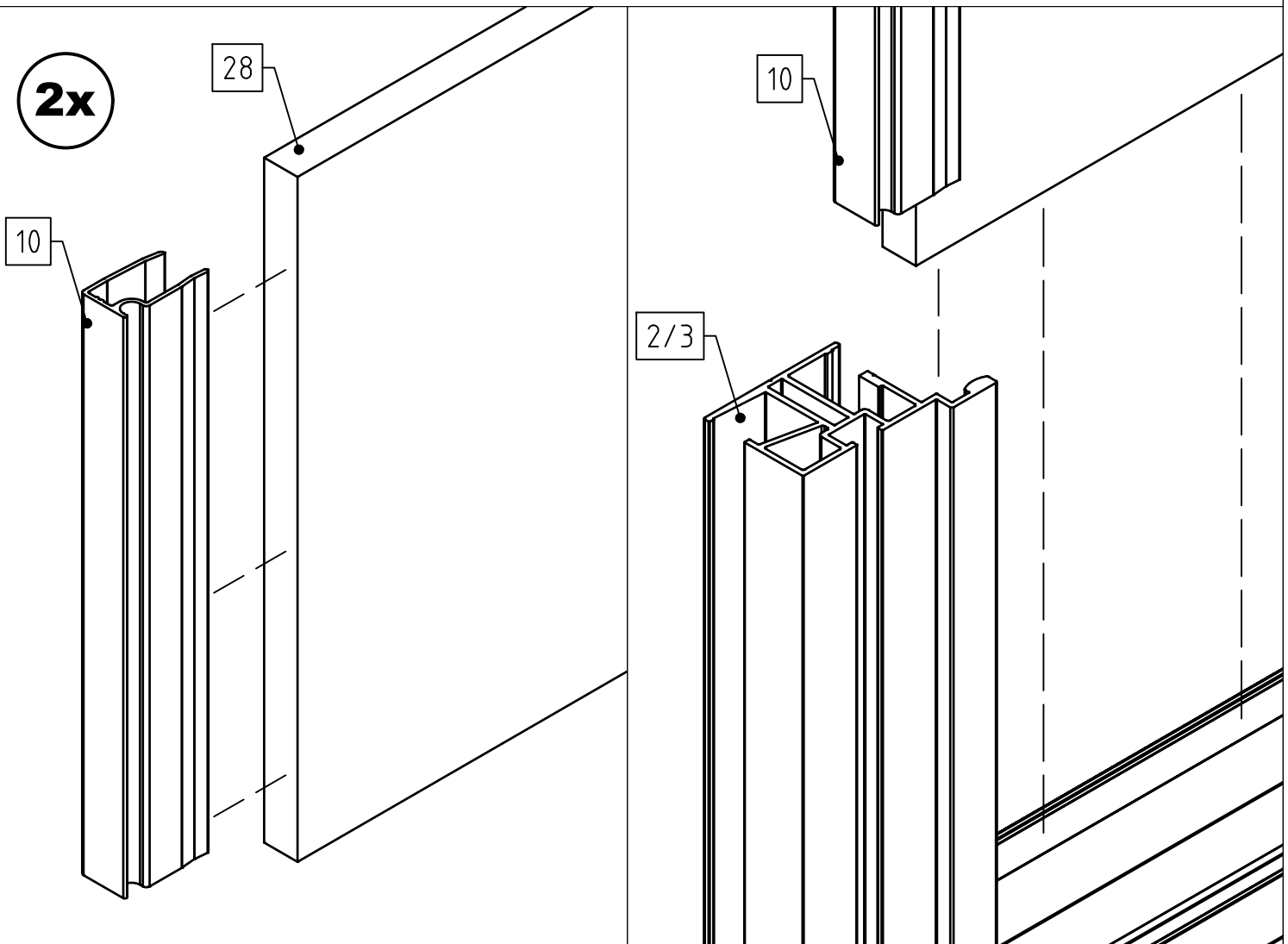

1

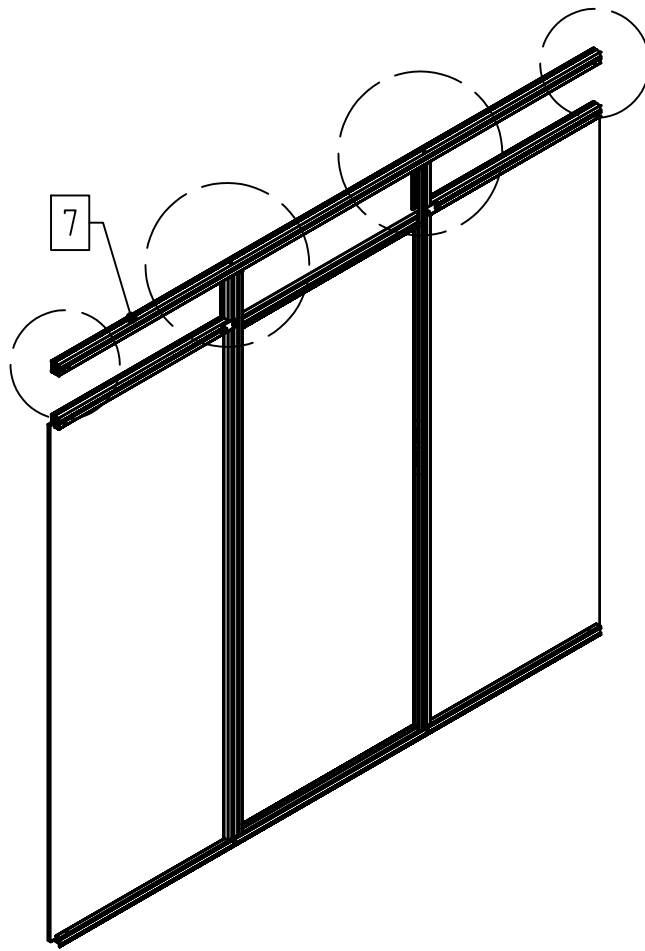

2x

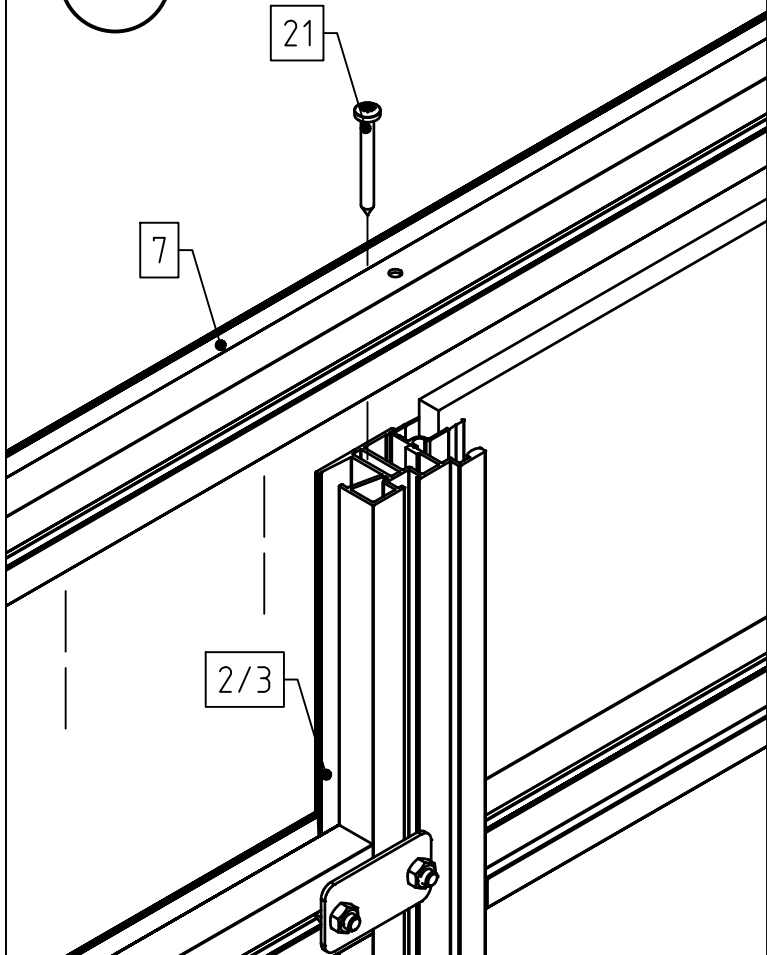

2x

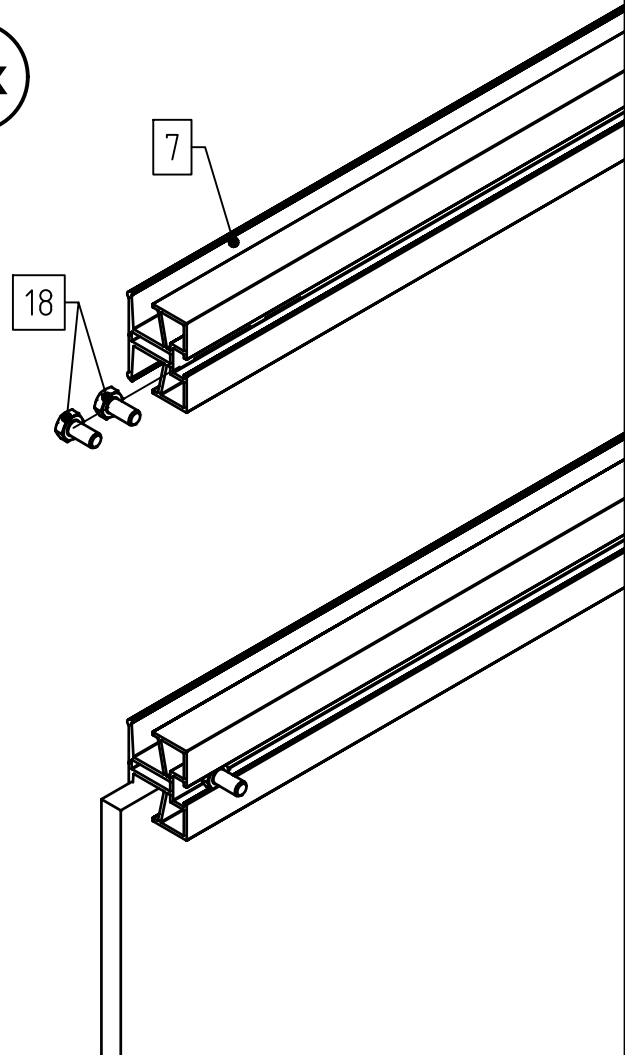

1

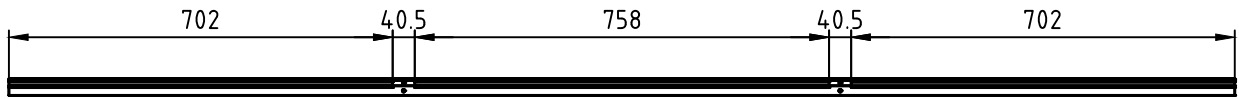
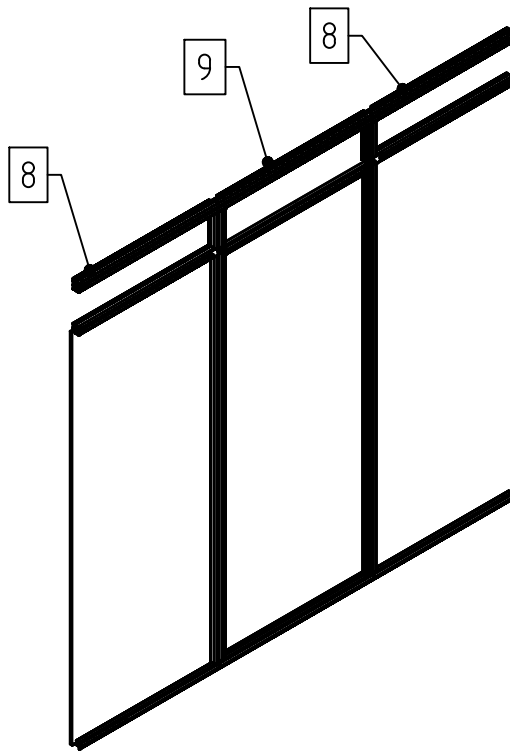

3x

8/9

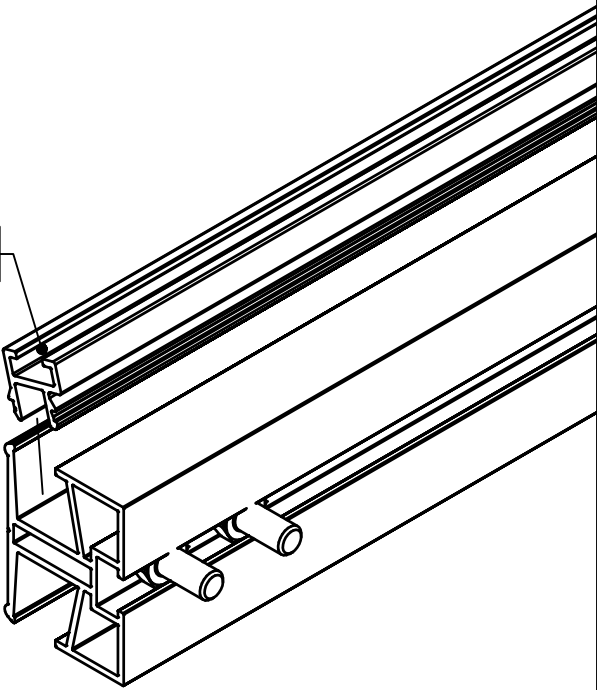

8/9

7

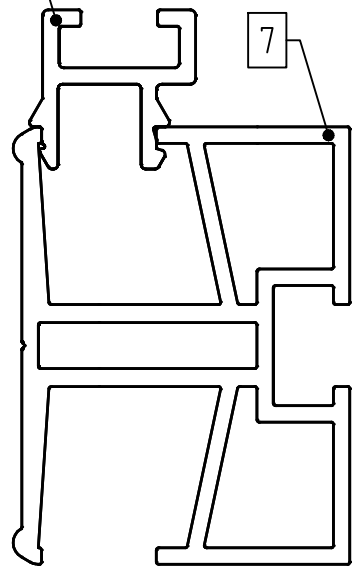

1

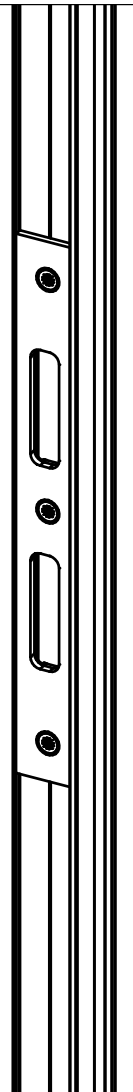
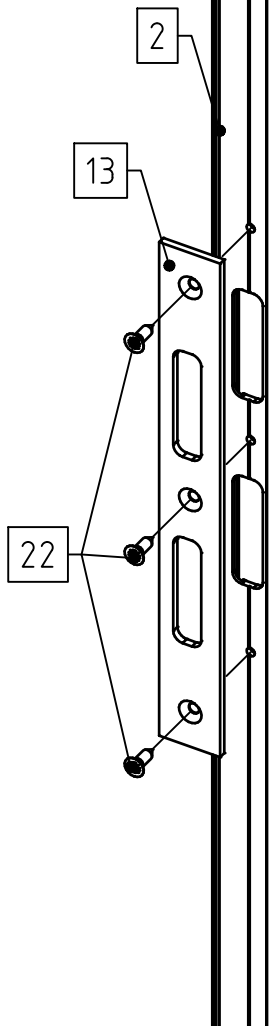
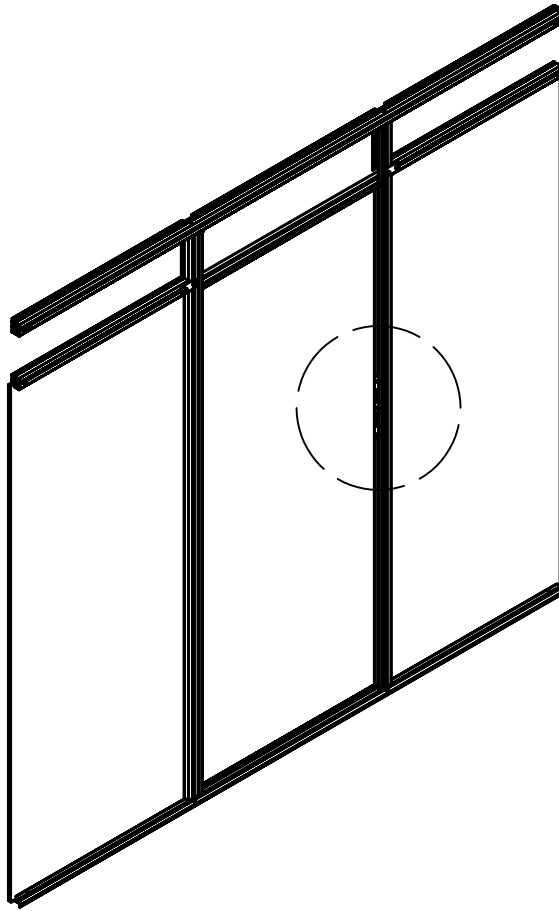

A

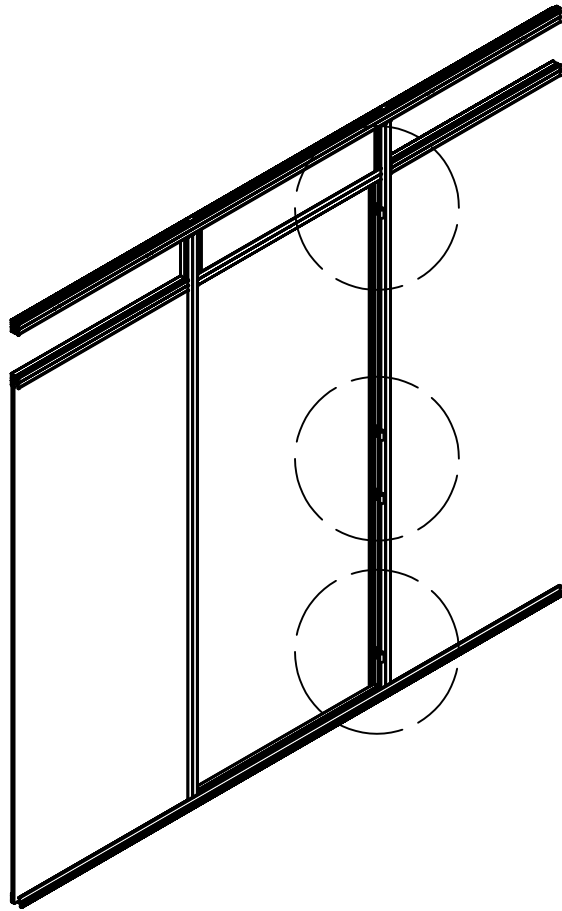

4x

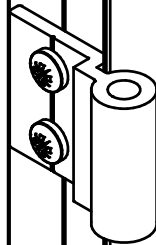
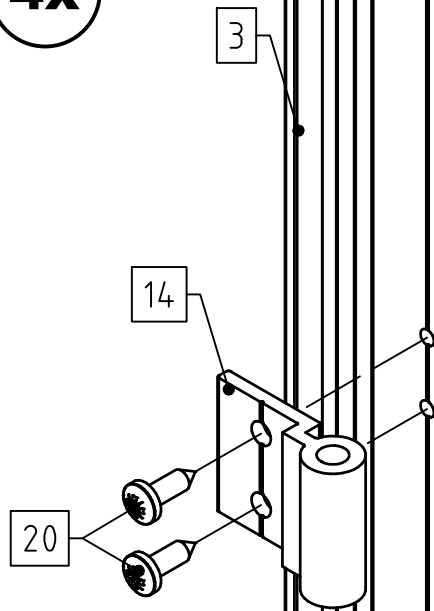

A

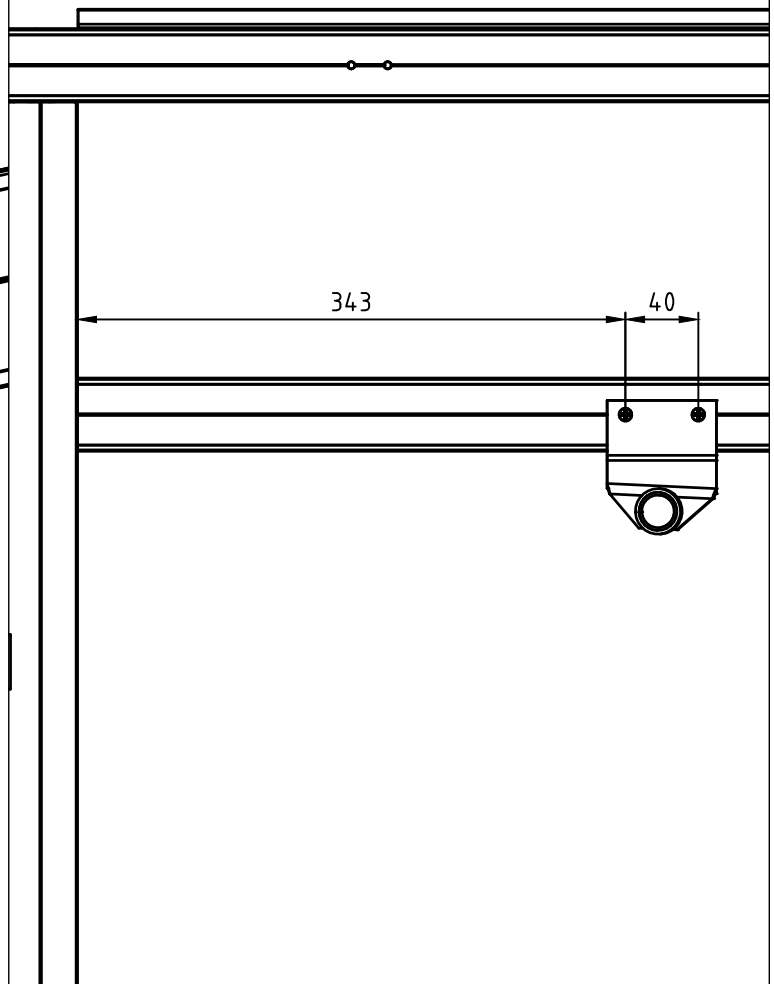
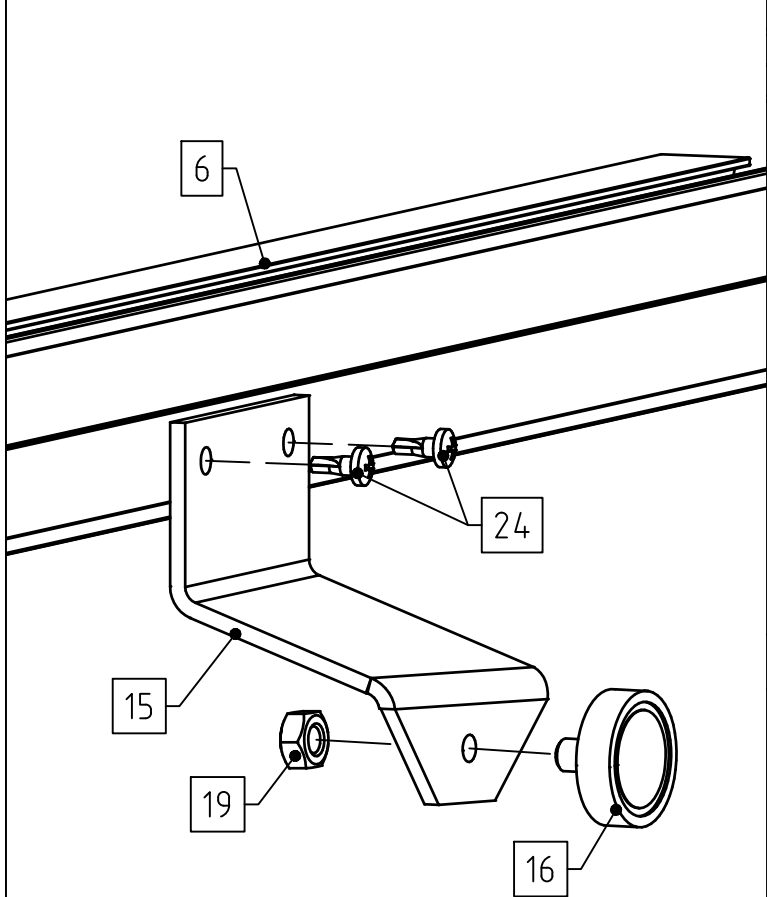
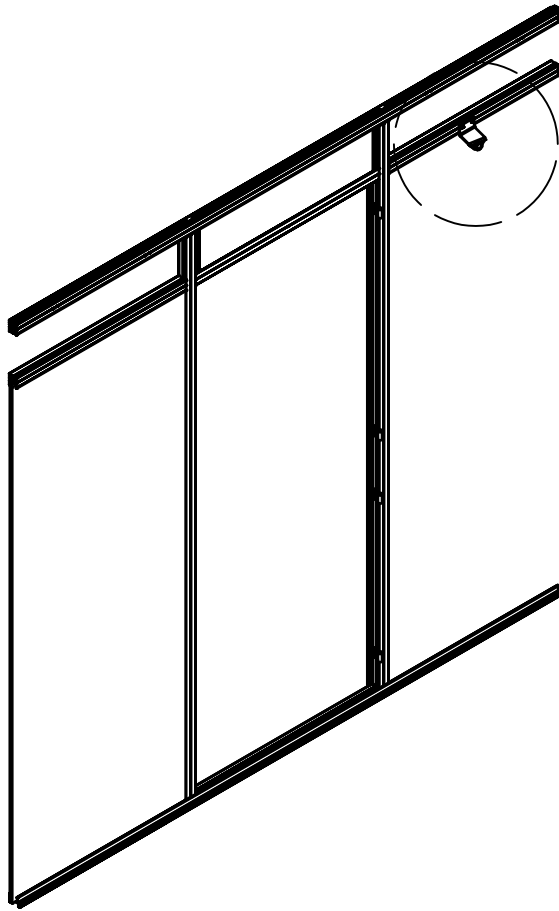

A

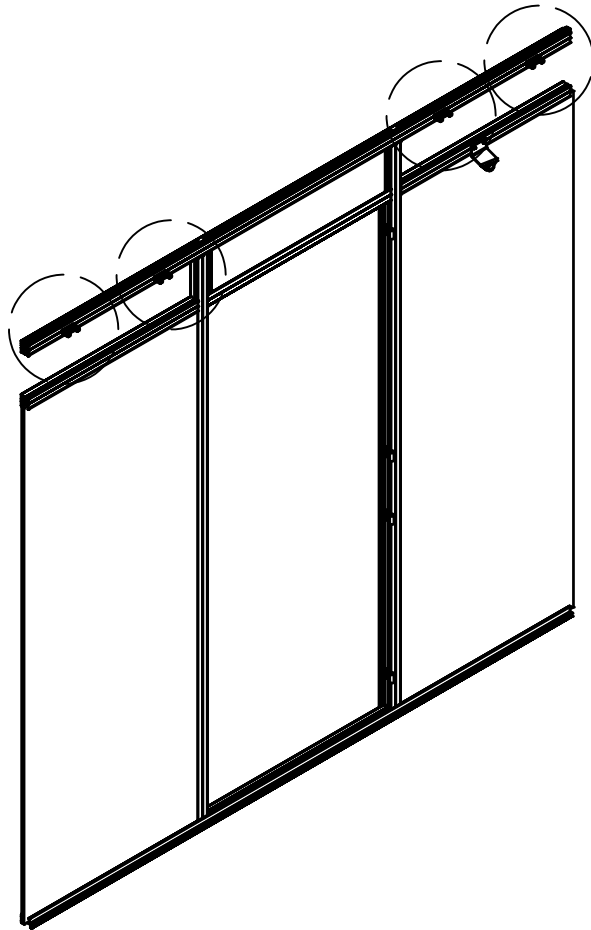

4x

7

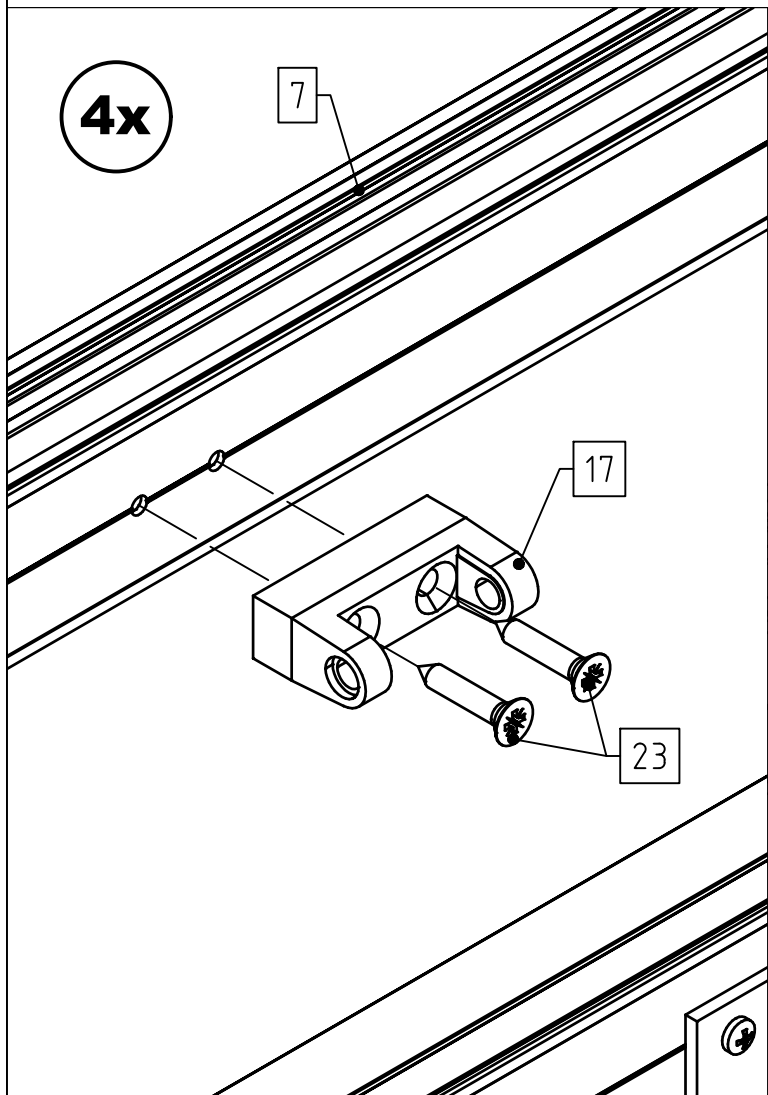

17

23

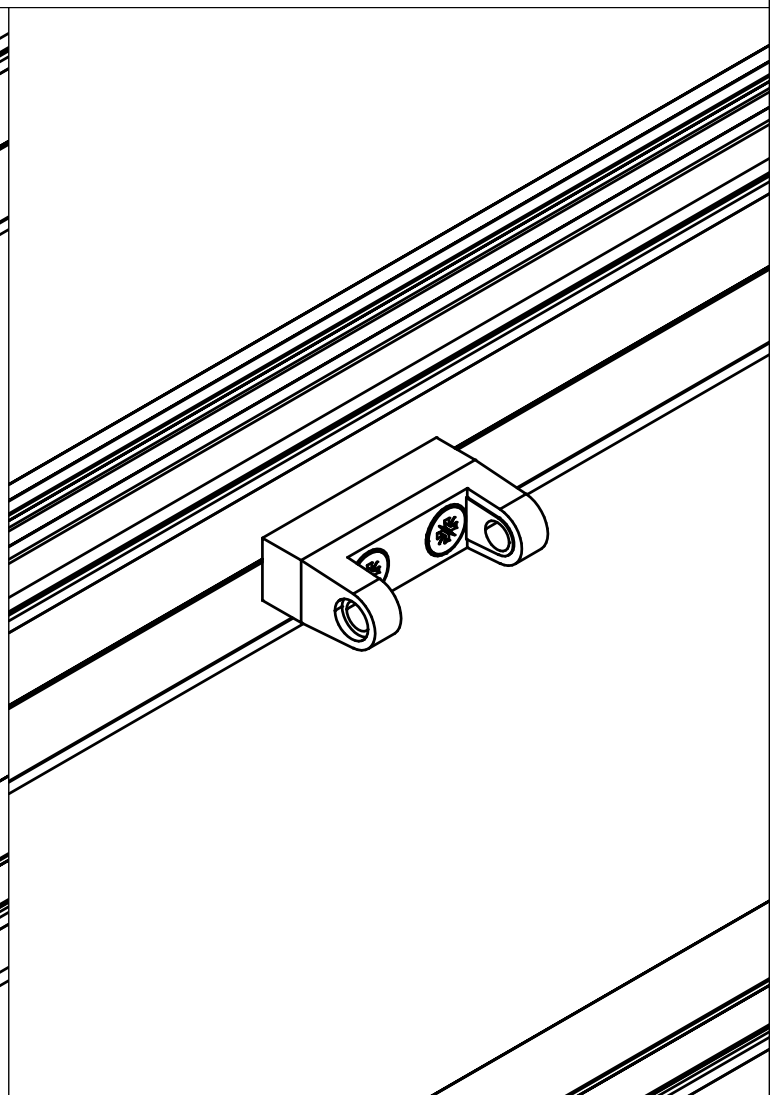

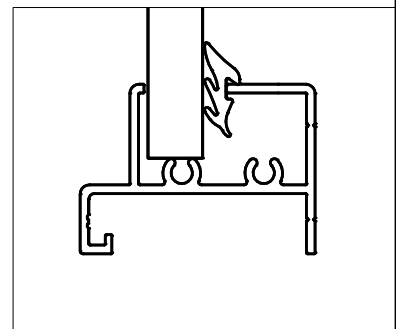
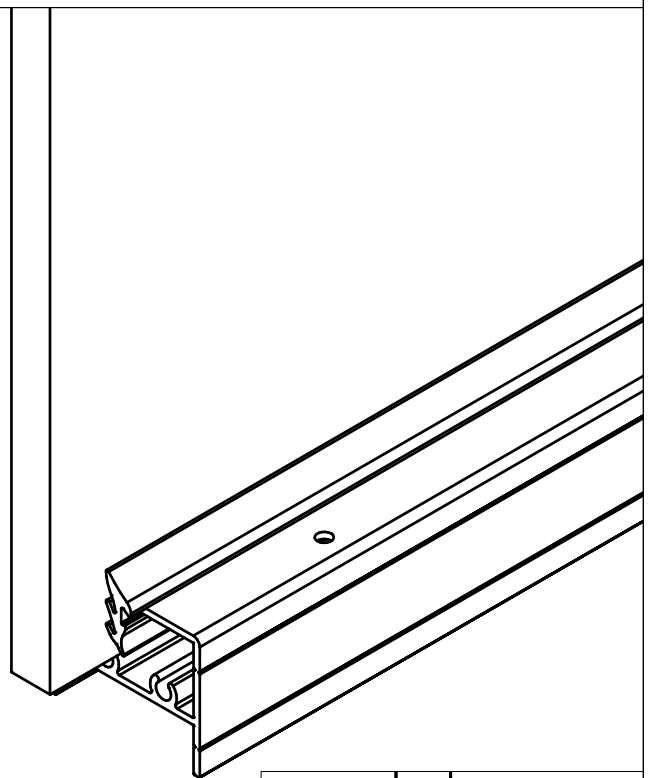
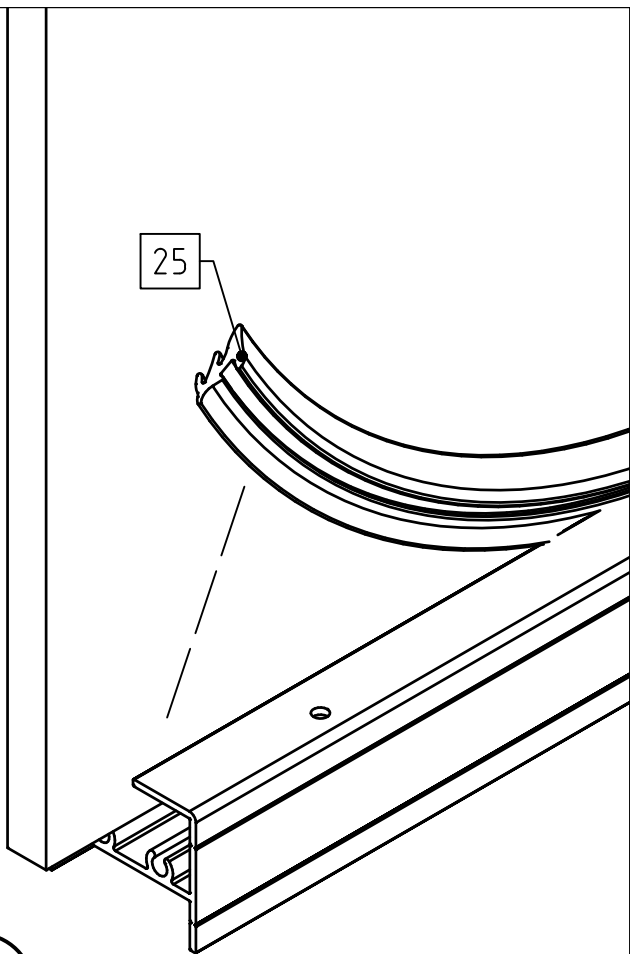
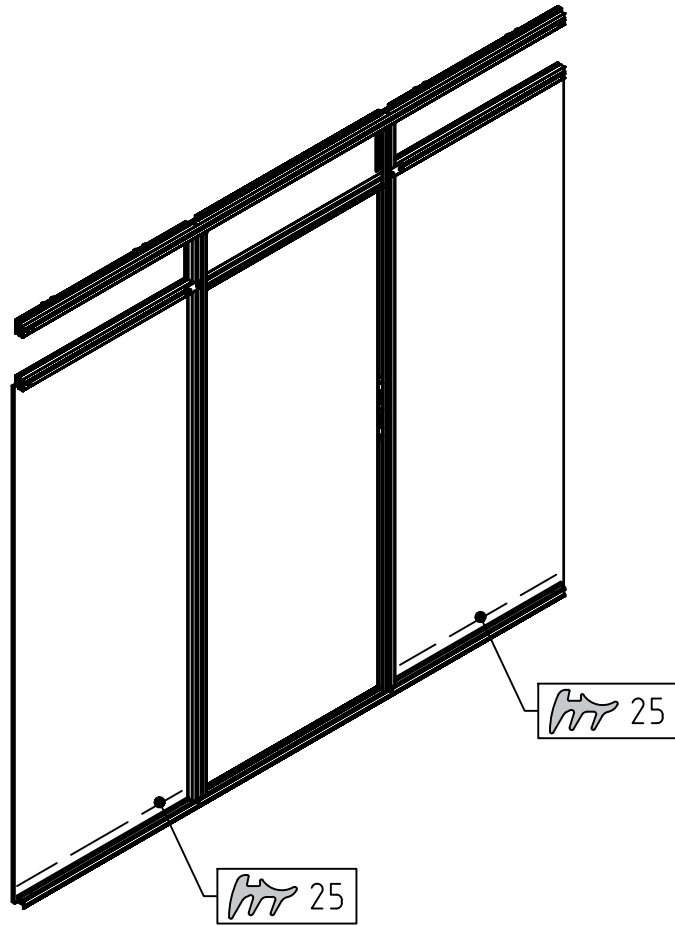

2x

VD

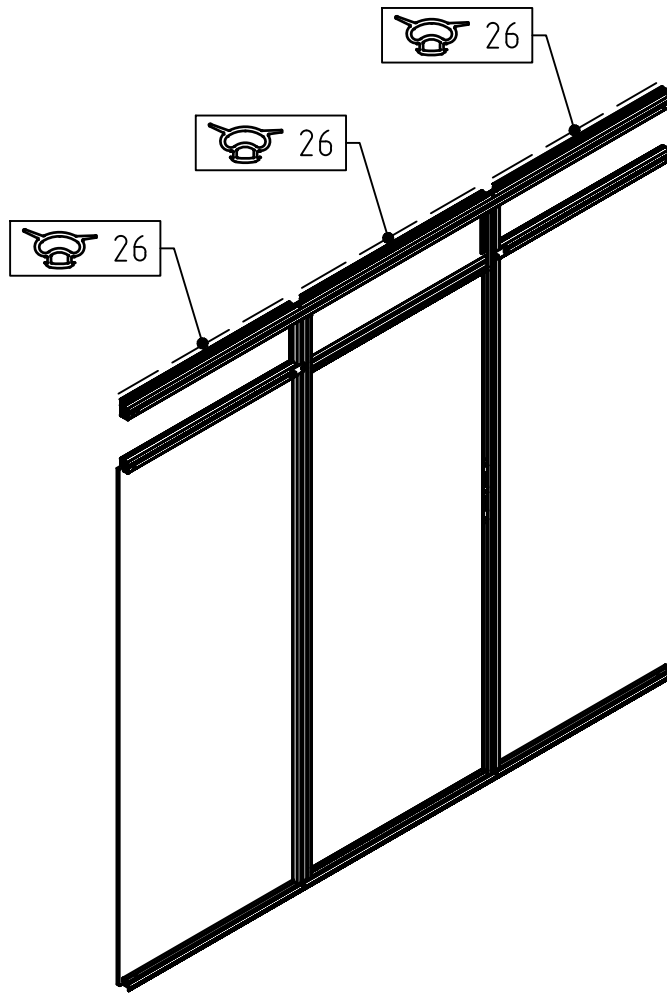

3x

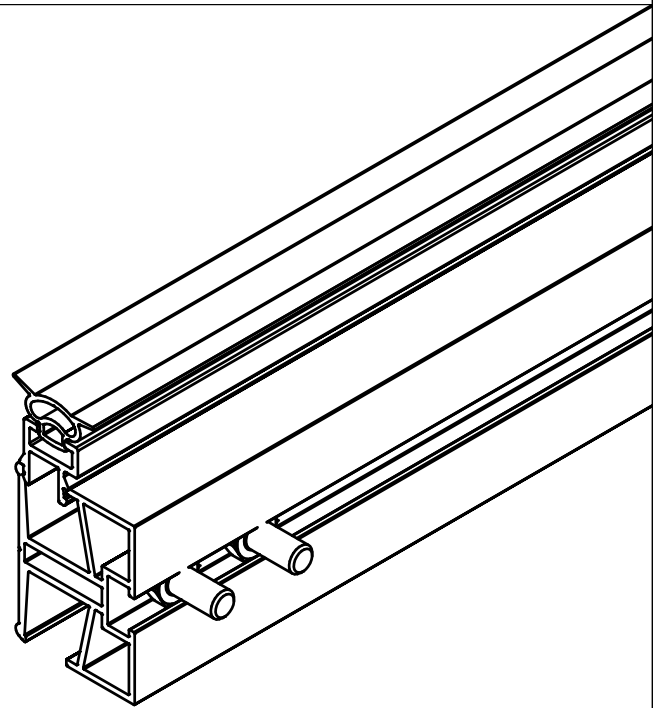
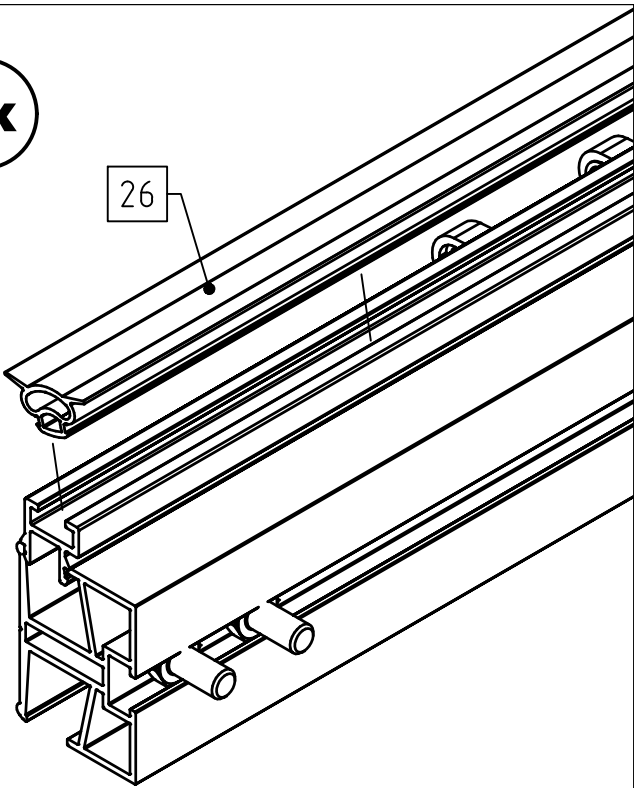

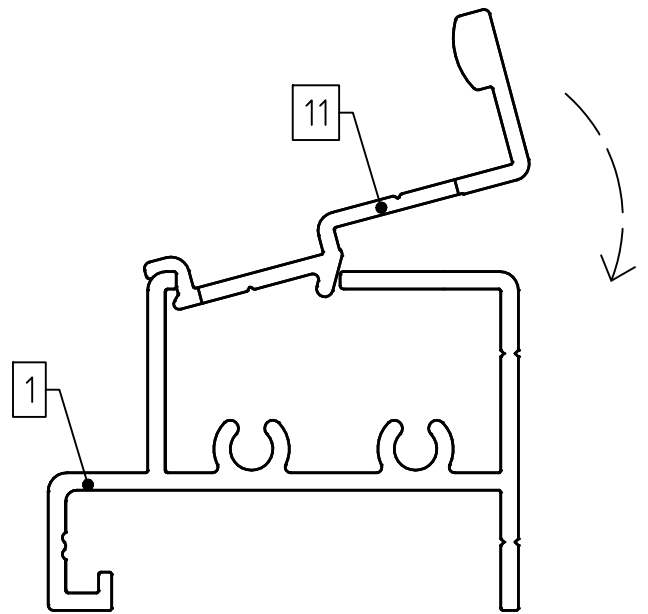
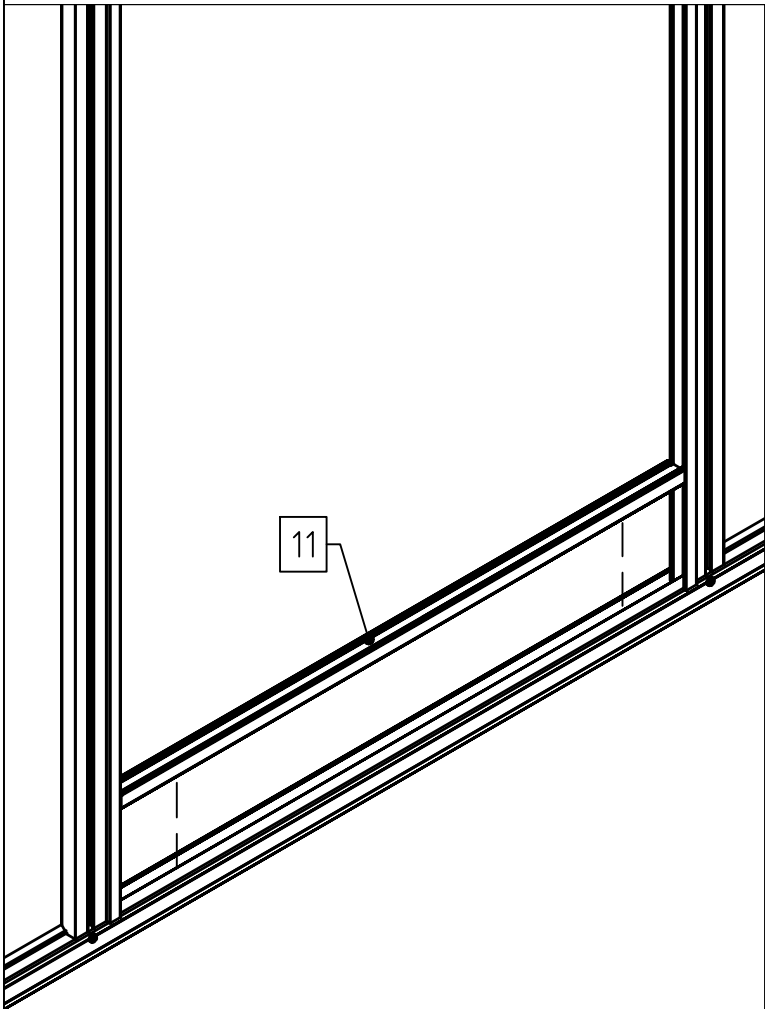
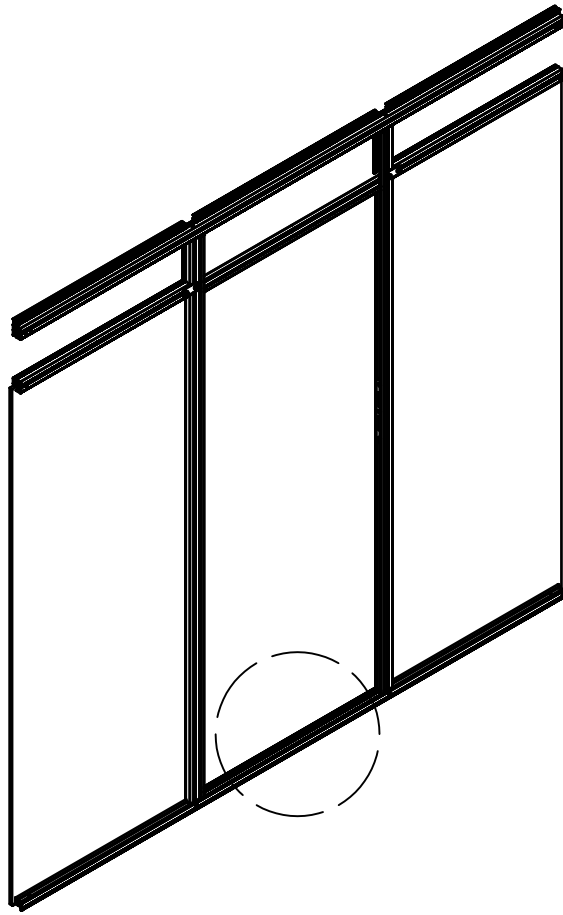

1



VD

STÜCKLISTE

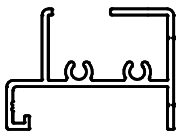
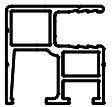
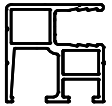
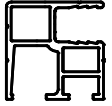
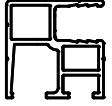
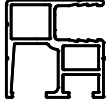
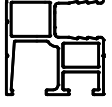
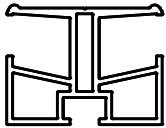
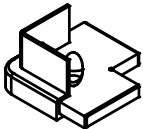
Seitenelement Linea I

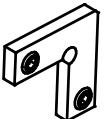
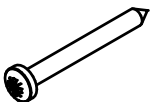
Pos.	Abbildung	Art.-Nr.	Bezeichnung	Anzahl	Bemerkung
1		P063-19-01-00-04-1	Bodenprofil 10 mm	2	1014 mm
2		P076-44-01-00-04-1	Randsprosse 10mm (hinten links)	1	2012 mm
3		P076-45-01-00-04-1	Randsprosse 10mm (hinten rechts)	1	2012 mm
4		P076-09-01-00-04-1	Randsprosse 10mm (vorne links)	1	2077 mm
5		P076-10-01-00-04-1	Randsprosse 10mm (vorne rechts)	1	2077 mm
6		P076-46-01-00-04-1	Randsprosse 10mm (oben links)	1	1574 mm
7		P076-47-01-00-04-1	Randsprosse 10mm (oben rechts)	1	1574 mm
8		P077-49-01-00-04-1	Mittelsprosse 10mm	2	1018 mm
9		9999000003	Eckverbinder Bodenprofil 10mm	4	
10		9999000097	Blindstopfen	4	
11		9999000070	Verbindungswinkel 30 x 30 x 4 mm (mit Madenschrauben)	2	
12		9999000150	Linsenkopfschraube 4,8 x 45	4	DIN 7981

STÜCKLISTE

Seitenelement Linea I

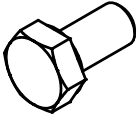
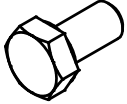
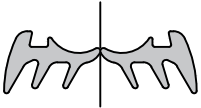
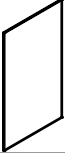
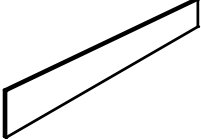
Pos.	Abbildung	Art.-Nr.	Bezeichnung	Anzahl	Bemerkung
13		9999000124	Sechskantschraube M6 x 12	2	DIN 933
14		9999000122	Sechskantschraube M6 x10	4	DIN 933
15		9999000119	Keildichtung 3-5 mm	1,03 lfdm. (Doppel- strang)	mittig auseinander ziehen
16			PC-Hohlkammerplatte 1048 x 1850 mm	2	
17			PC-Hohlkammerplatte 1048 x 219 mm	2	
18					
19					
20					
21					
22					
23					
24					

1

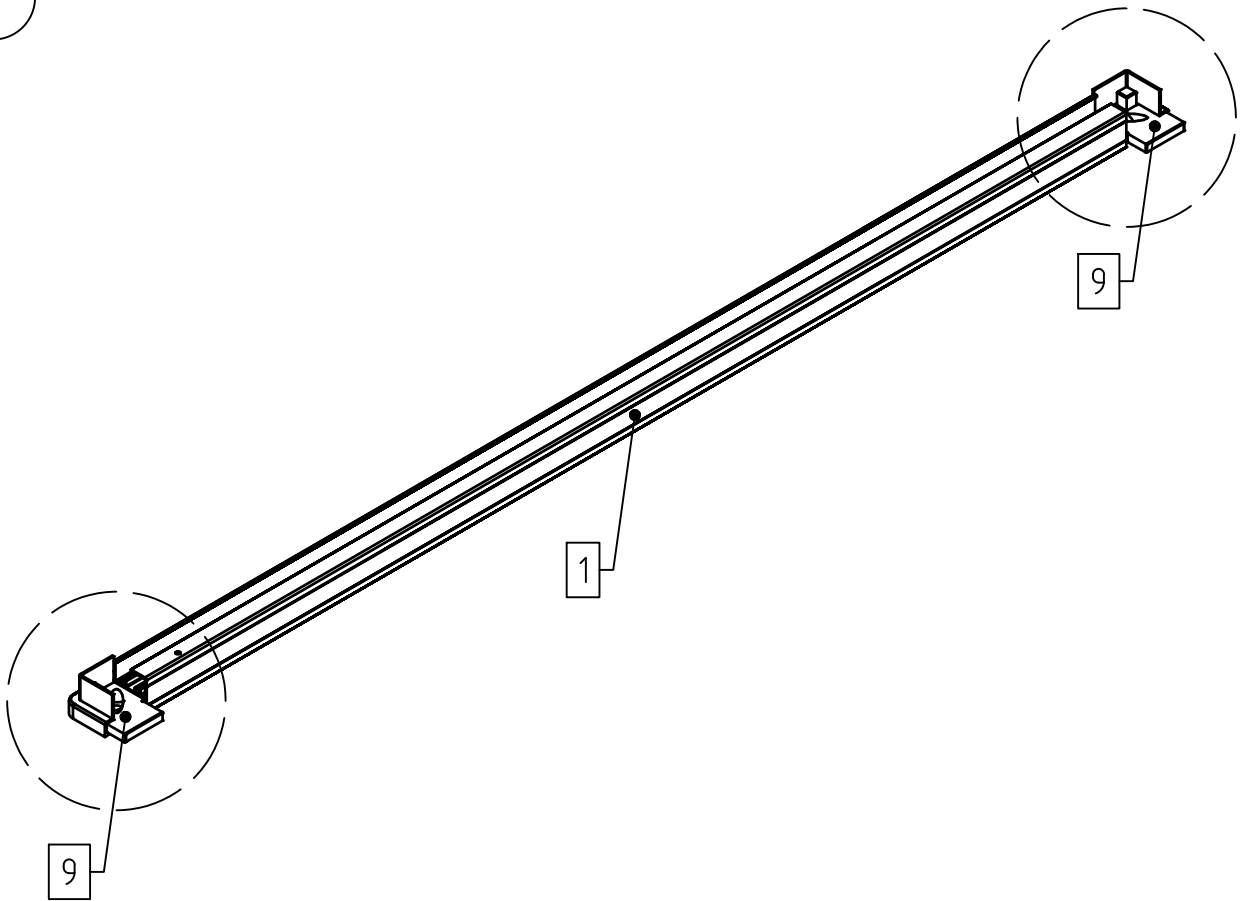

2x

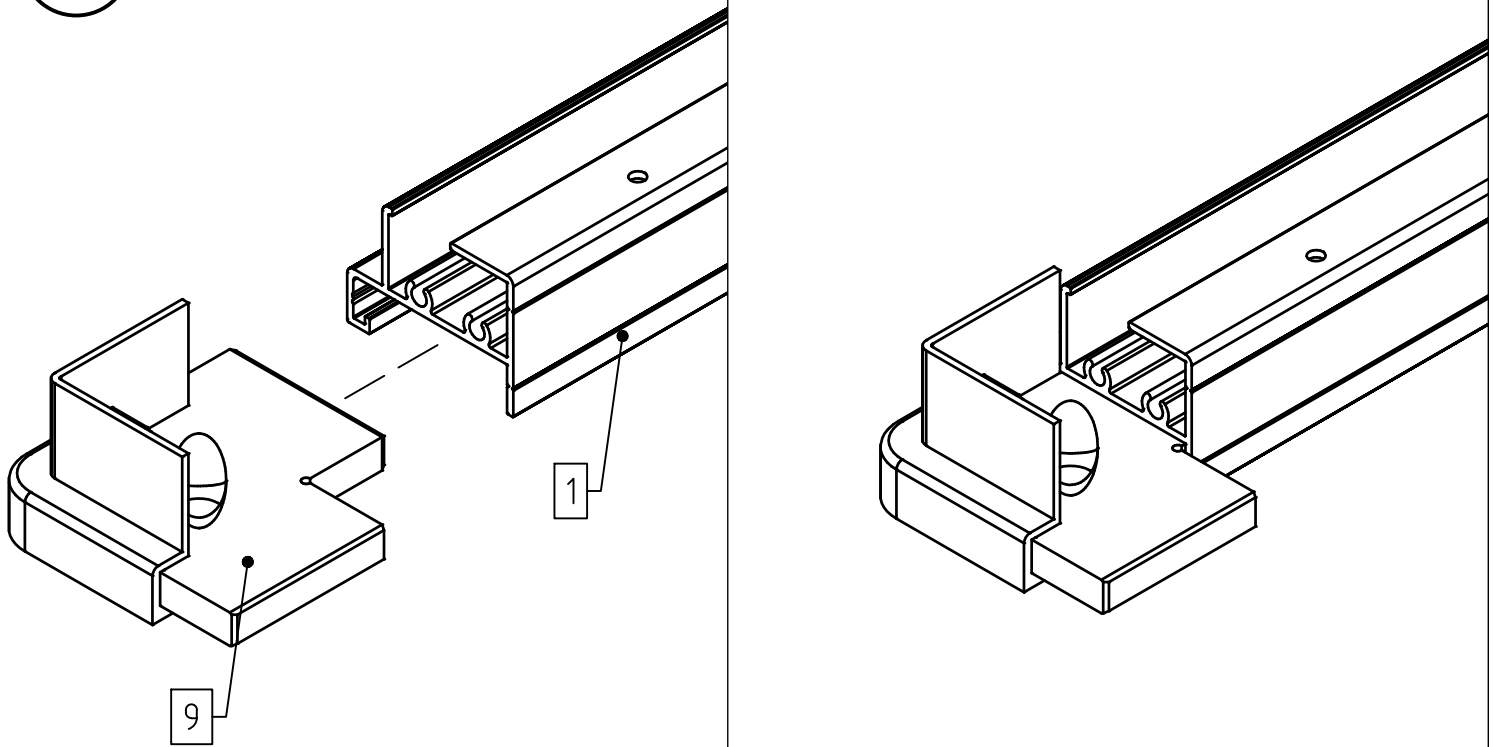

1

Gefälle beachten!

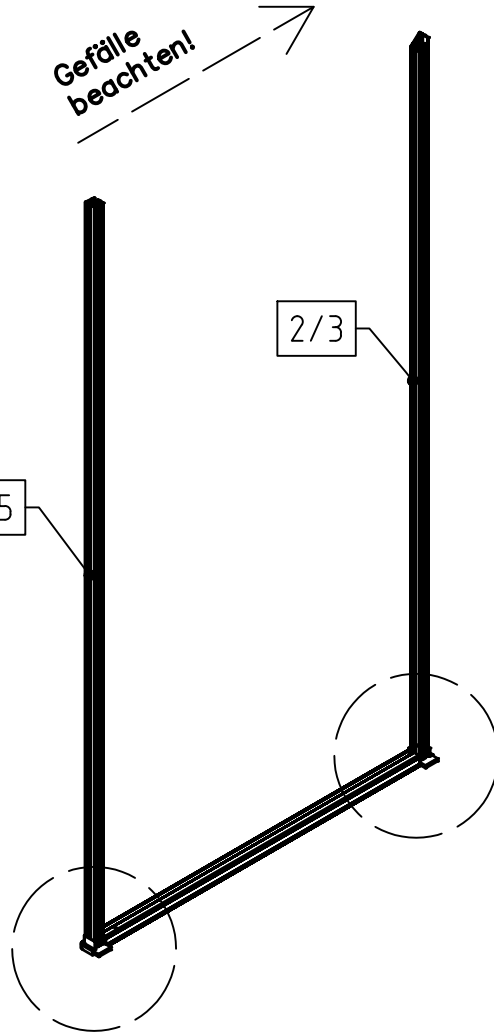

2x

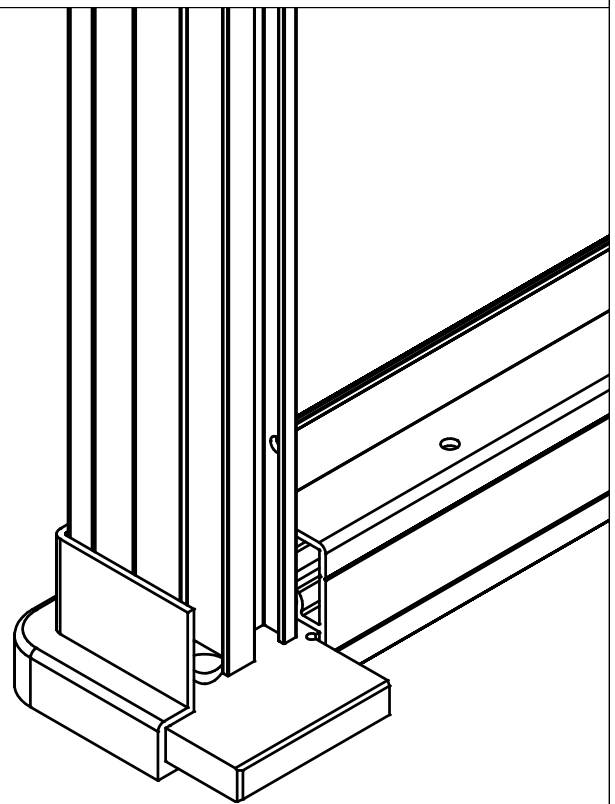
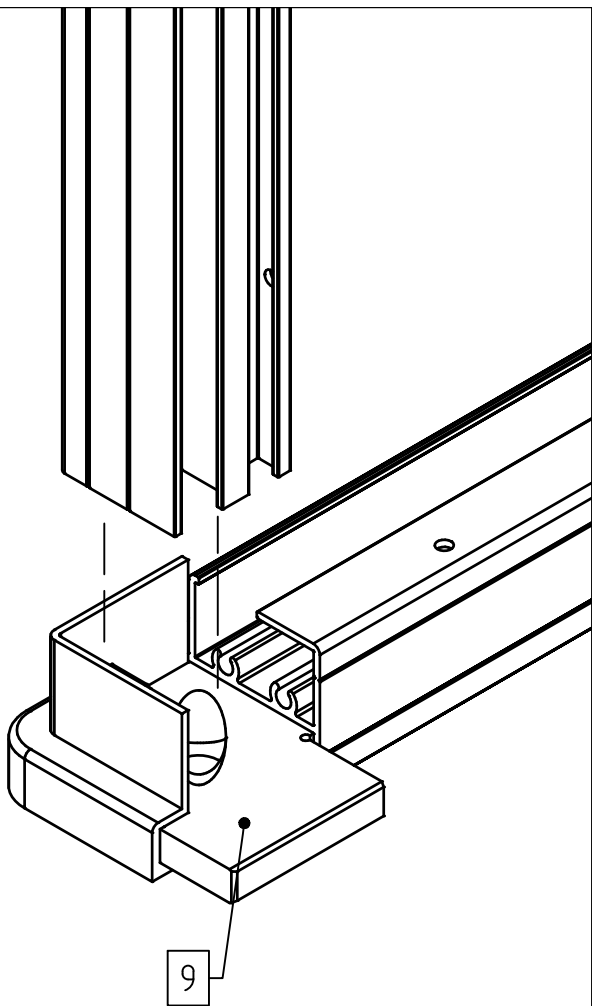

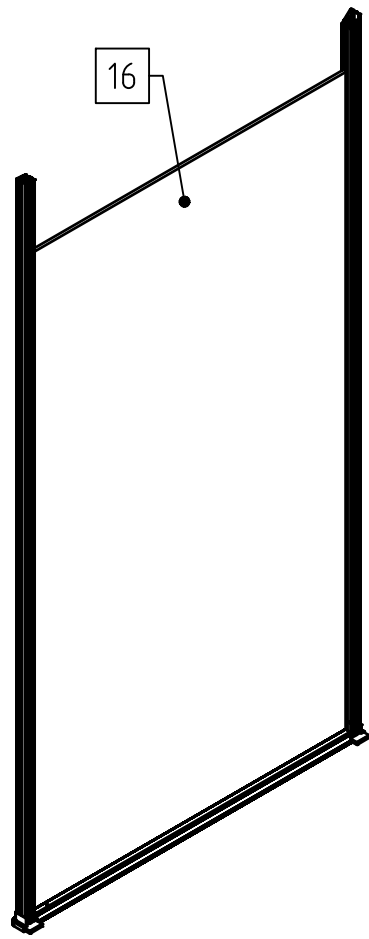

16

4/5

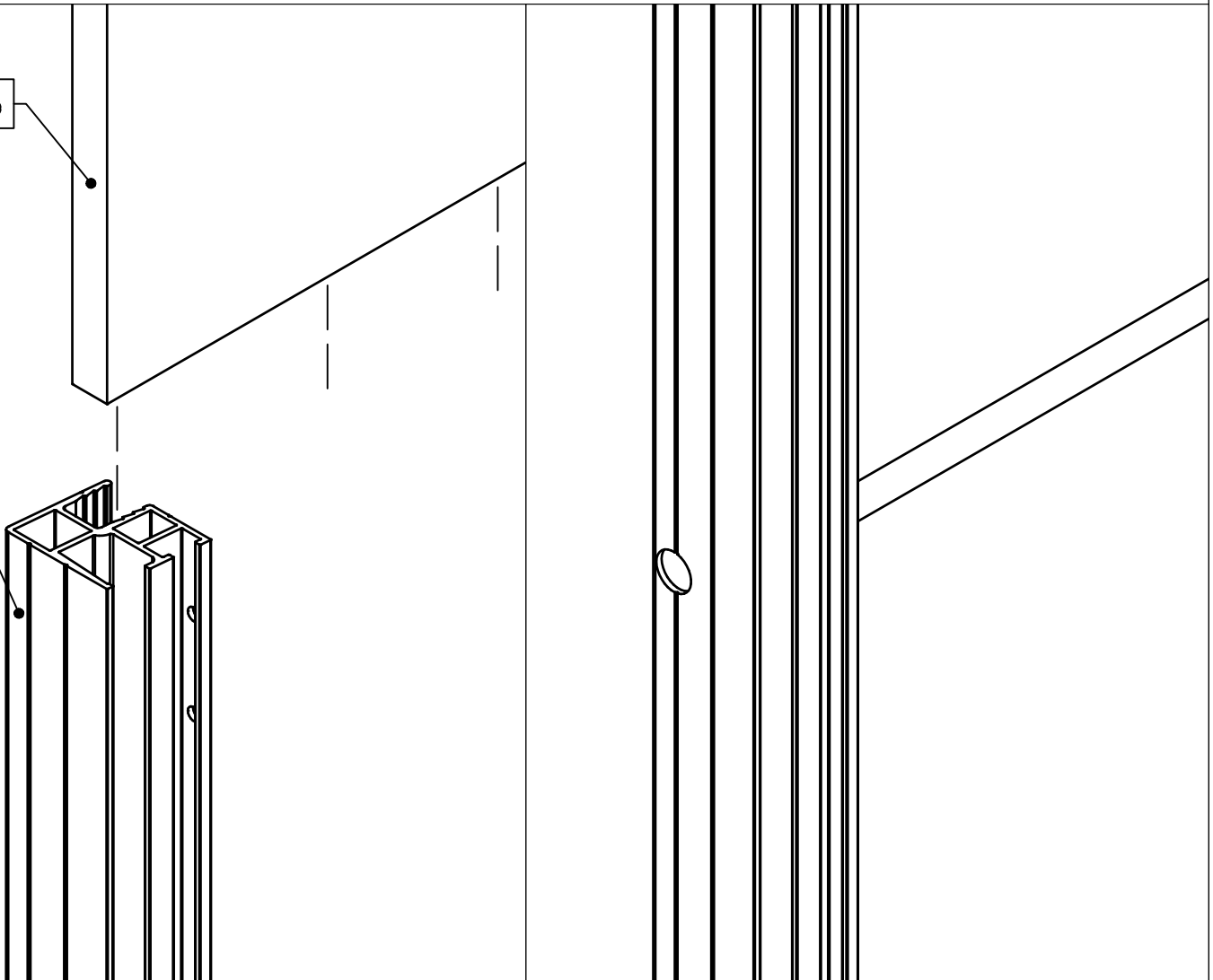

1

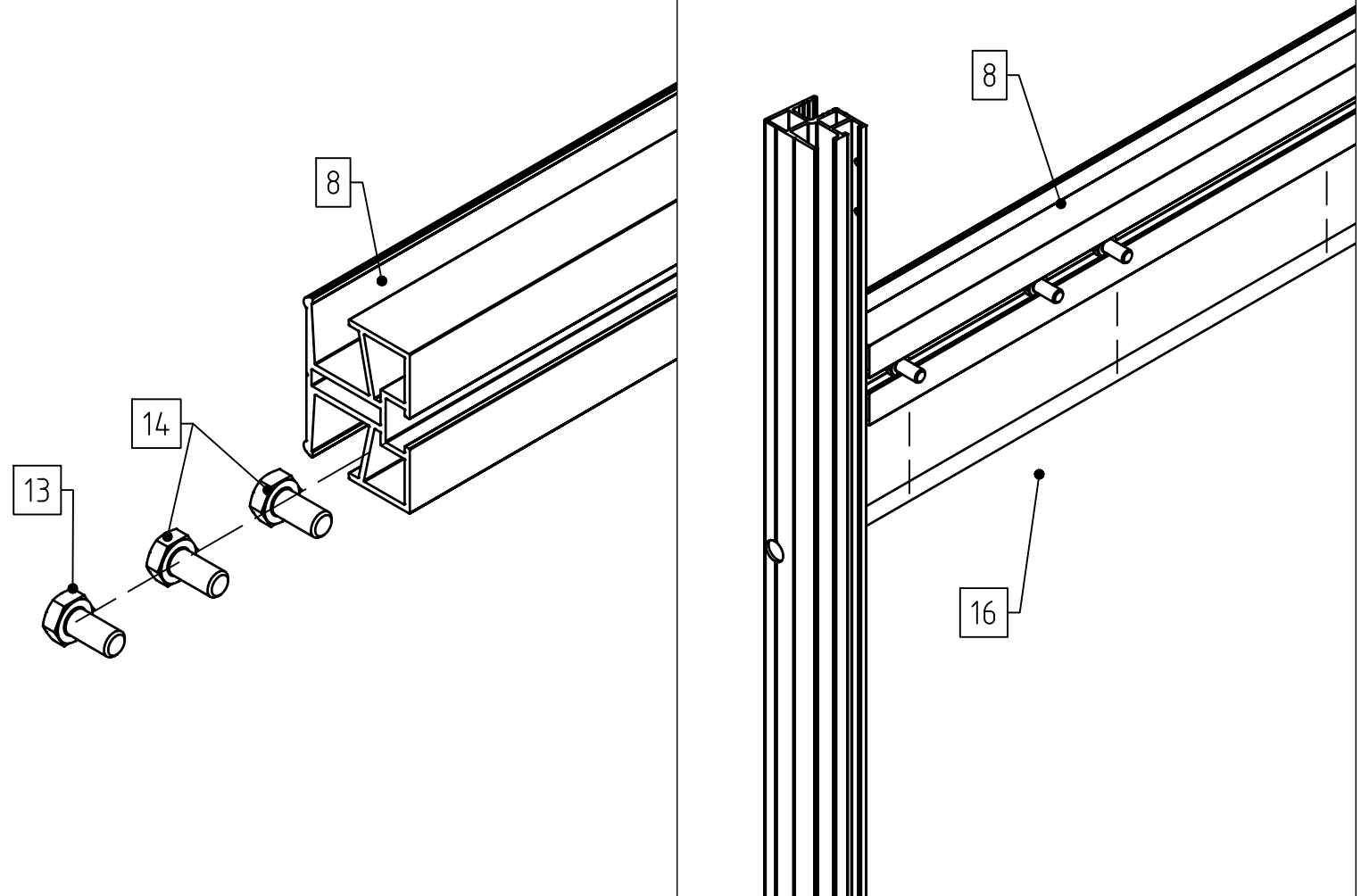
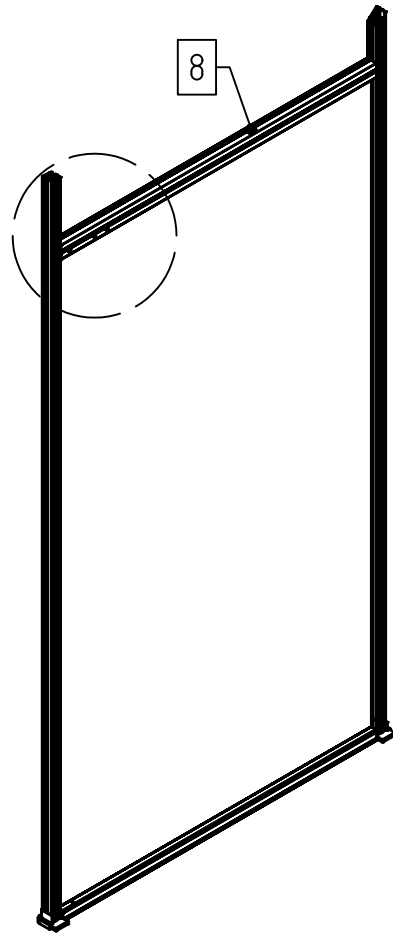

1

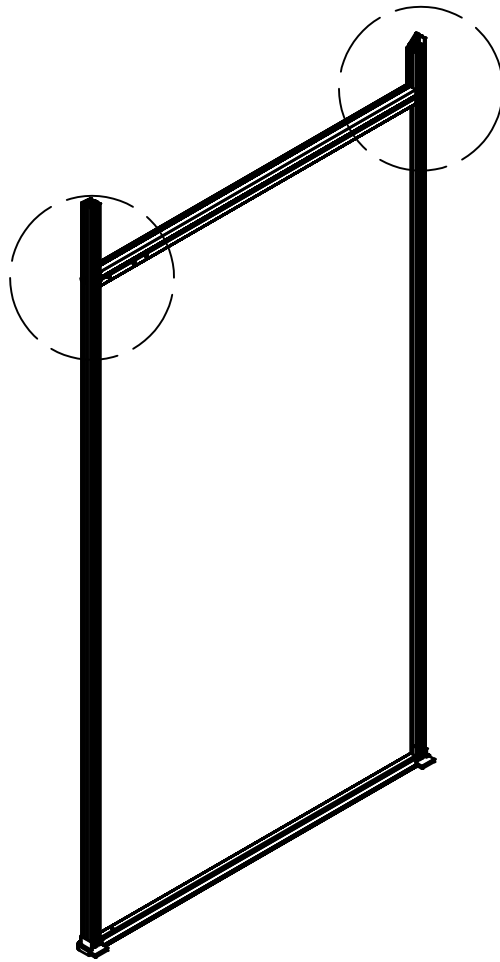

2x

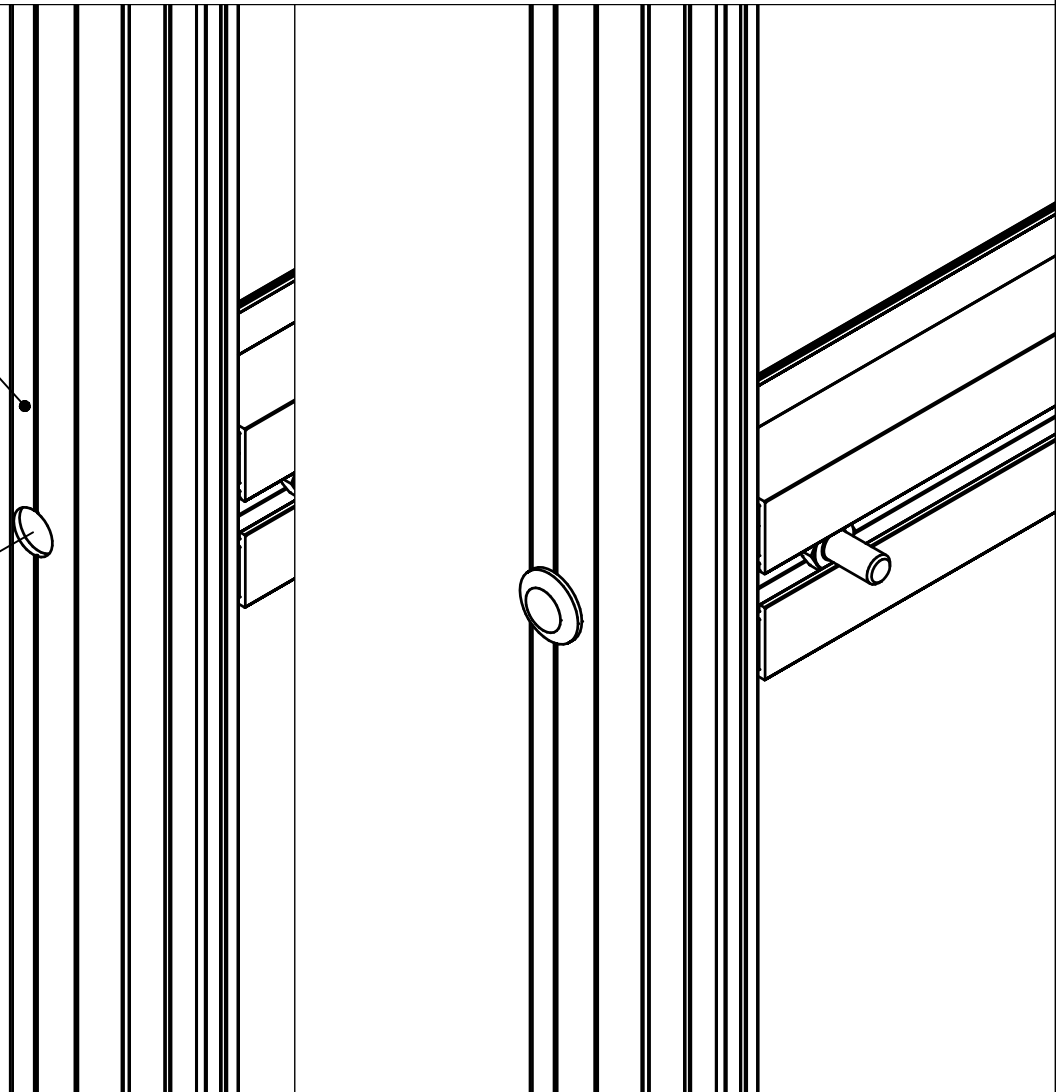
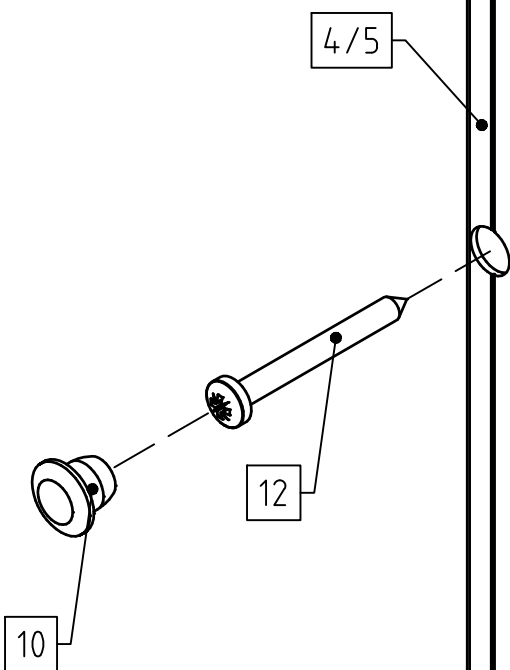

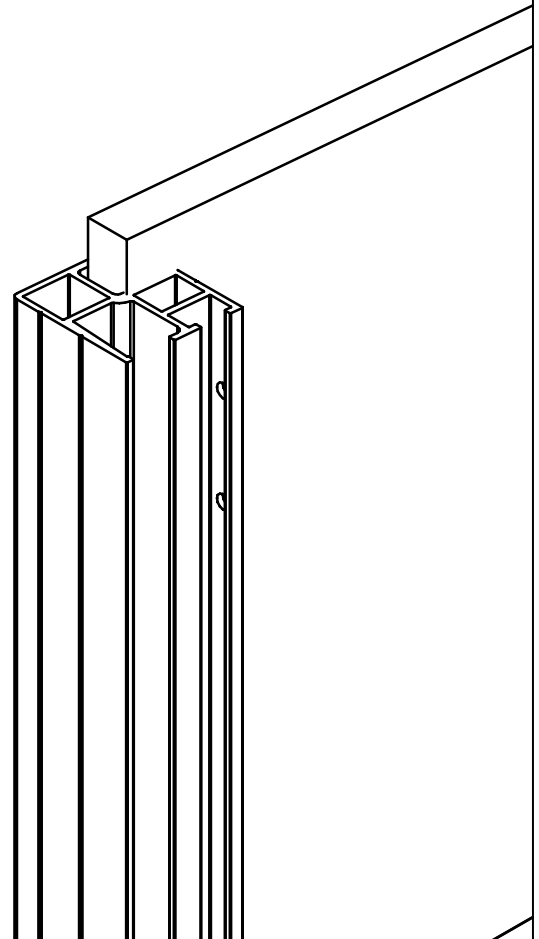
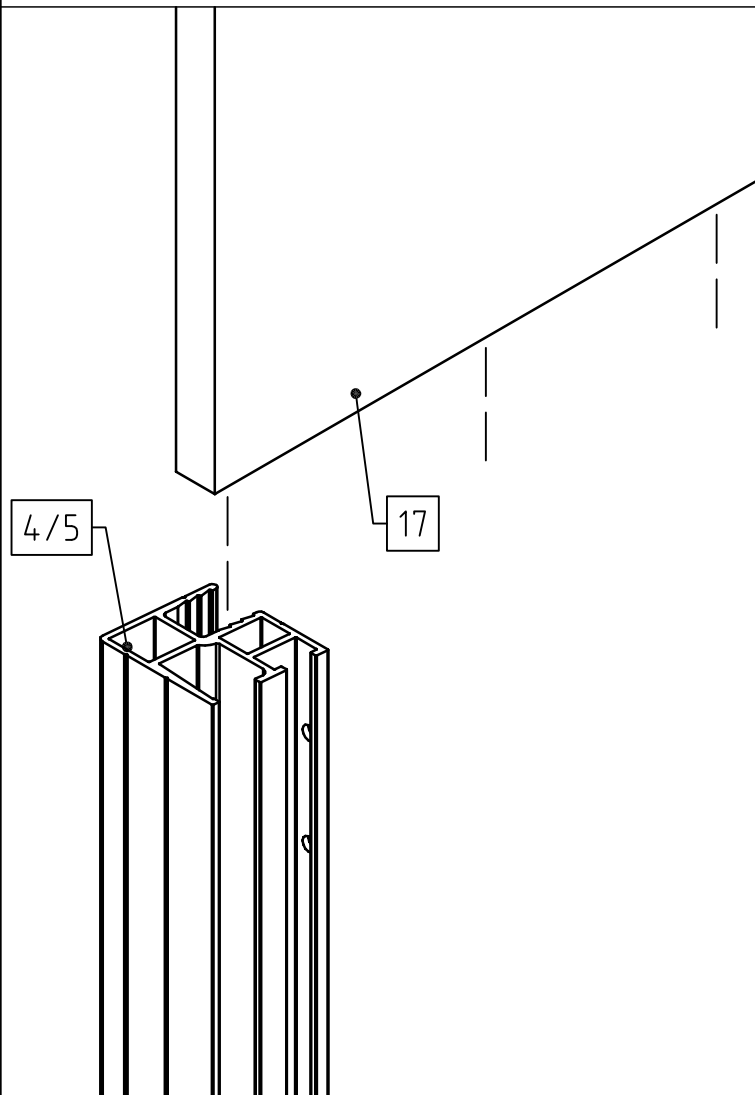
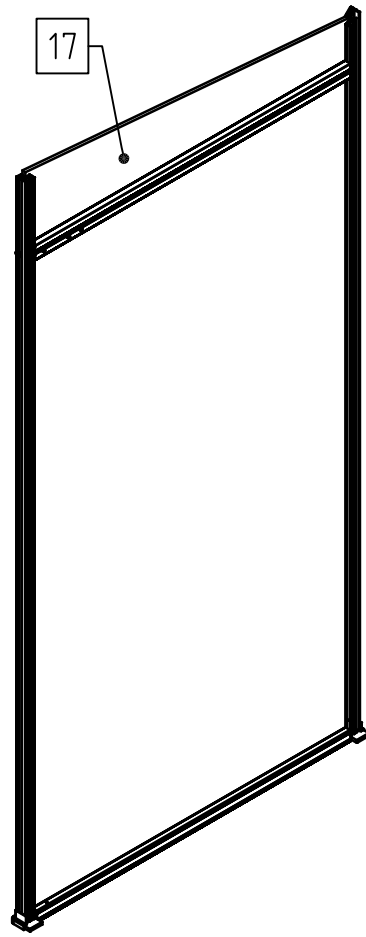

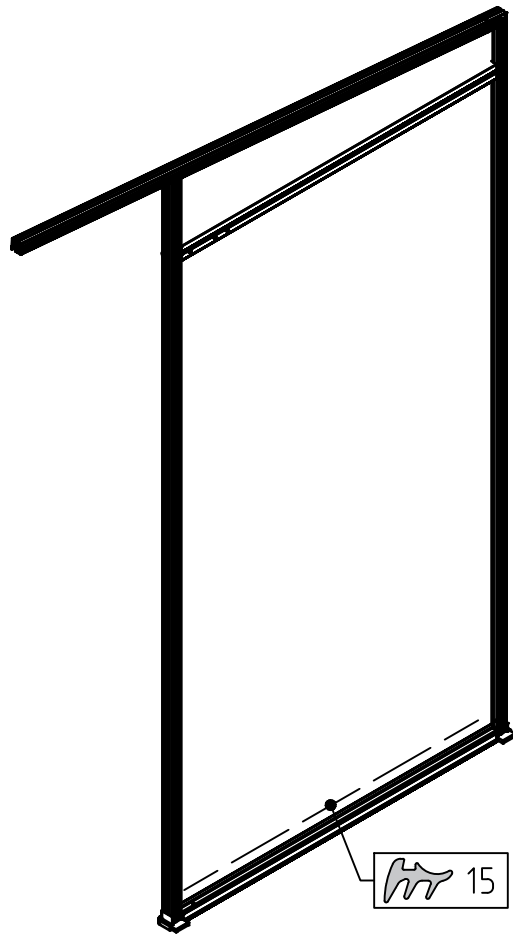

 15

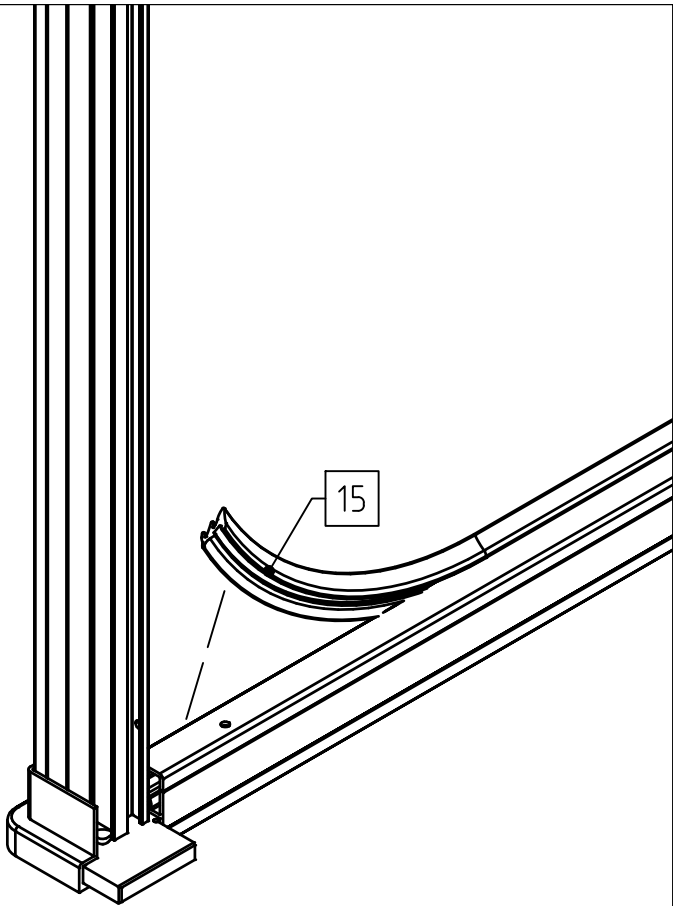



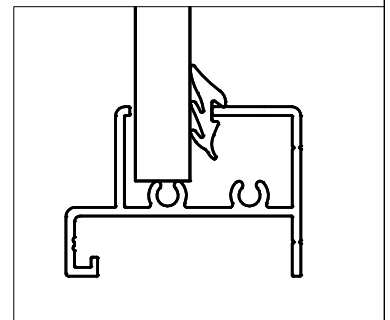
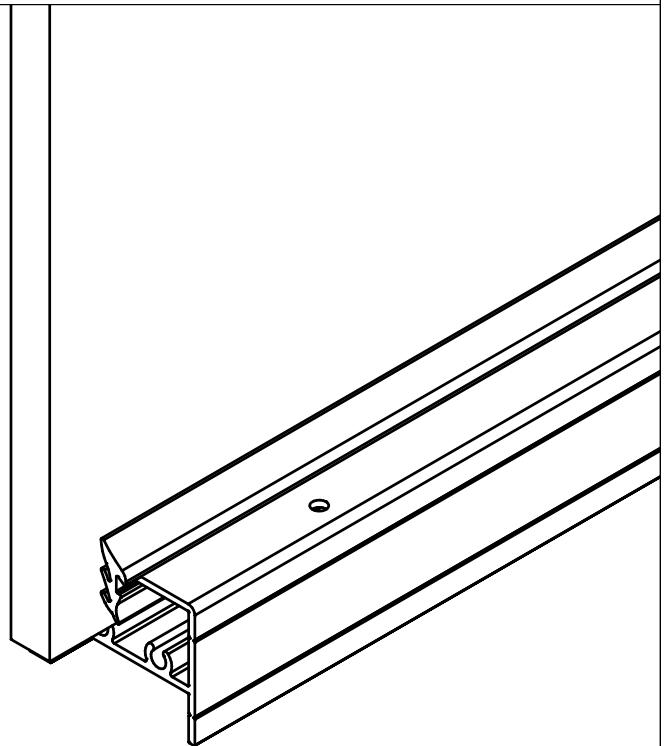



15

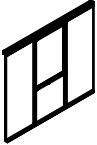
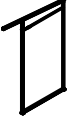
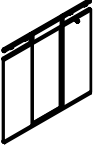
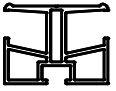
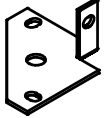

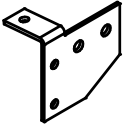

STÜCKLISTE

Zusammenbau Linea I

Pos.	Abbildung	Art.-Nr.	Bezeichnung	Anzahl	Bemerkung
1			Rückwandgiebel	1	
2			Seitenelement	2	
3			Rückwandgiebel	1	
4		P077-34-01-00-04-1	Mittelsprosse 10mm	2	1535 mm
5		9999001948	Befestigungsinnenecke links	2	
6		9999001949	Befestigungsinnenecke rechts	2	
7		9999000417	Eckverbinder Sprosse	2	
8		9999000419	Eckverbinder Traufe rechts	1	
9		9999000418	Eckverbinder Traufe links	1	
10		9999000097	Blindstopfen	4	
11		9999000128	Sechskantmutter M6	8	DIN 934
12		9999000144	Linsenkopfschraube 4,2 x 13	18	DIN 7981

STÜCKLISTE

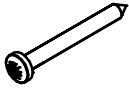
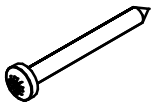
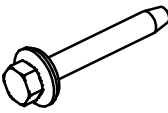
Zusammenbau Linea I

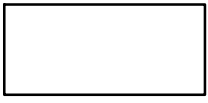
Pos.	Abbildung	Art.-Nr.	Bezeichnung	Anzahl	Bemerkung
13		9999000147	Linsenkopfschraube 4,2 x 38	2	DIN 7981
14		9999000150	Linsenkopfschraube 4,8 x 45	2	DIN 7981
15		9999000431	Fassadenbauschraube (mit Dichtscheibe) 6,3 x 45	2	
16		9999000121	Keildichtung 8 – 10 mm	2x 0,72m 1x 0,76m	
17			PC-Hohlkammerplatte 788 x 1559 mm	1	
18			PC-Hohlkammerplatte 733 x 1559 mm	2	
19					
20					
21					
22					
23					
24					

1

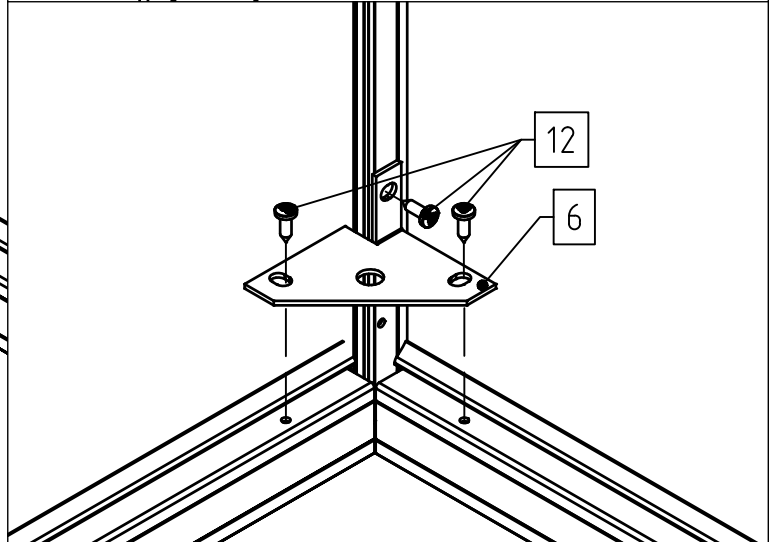
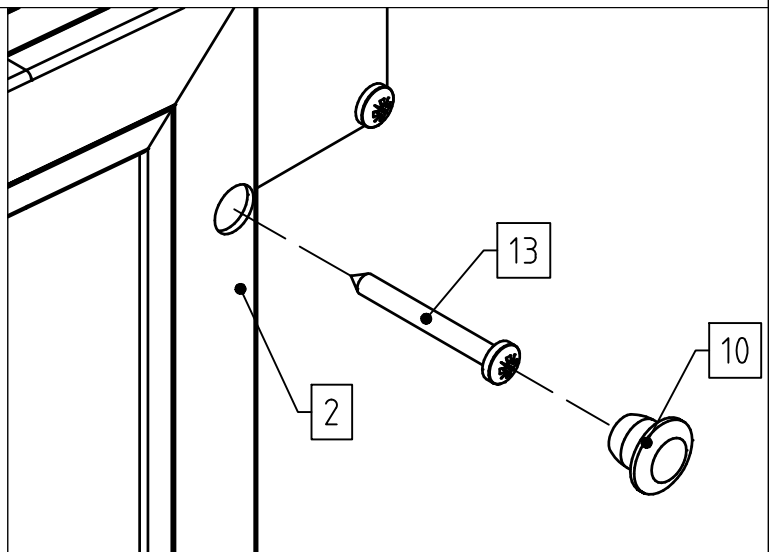
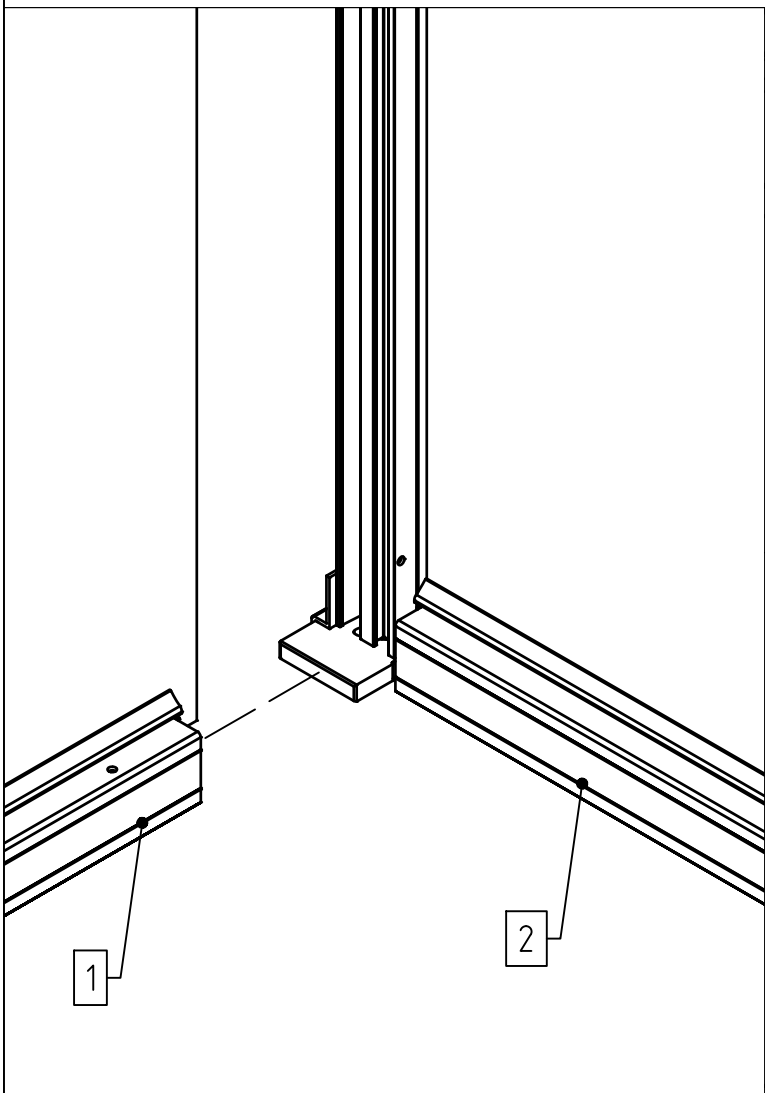
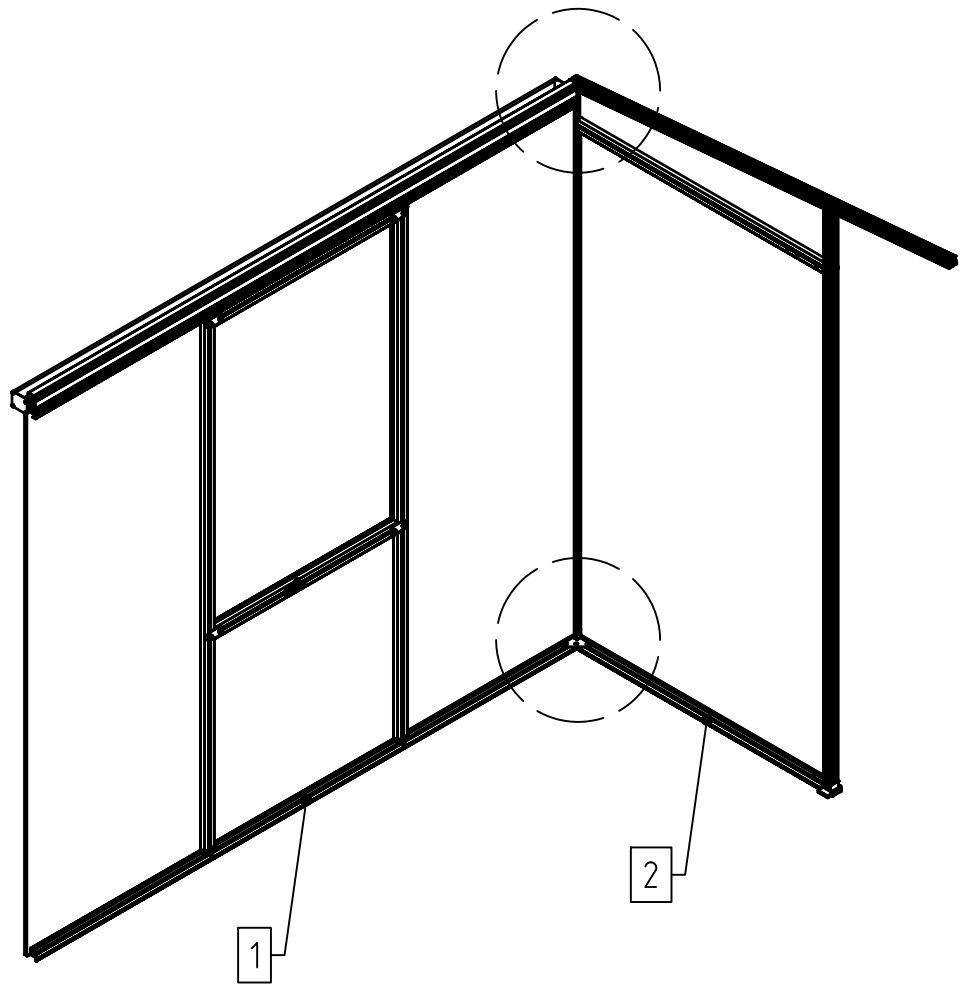

1

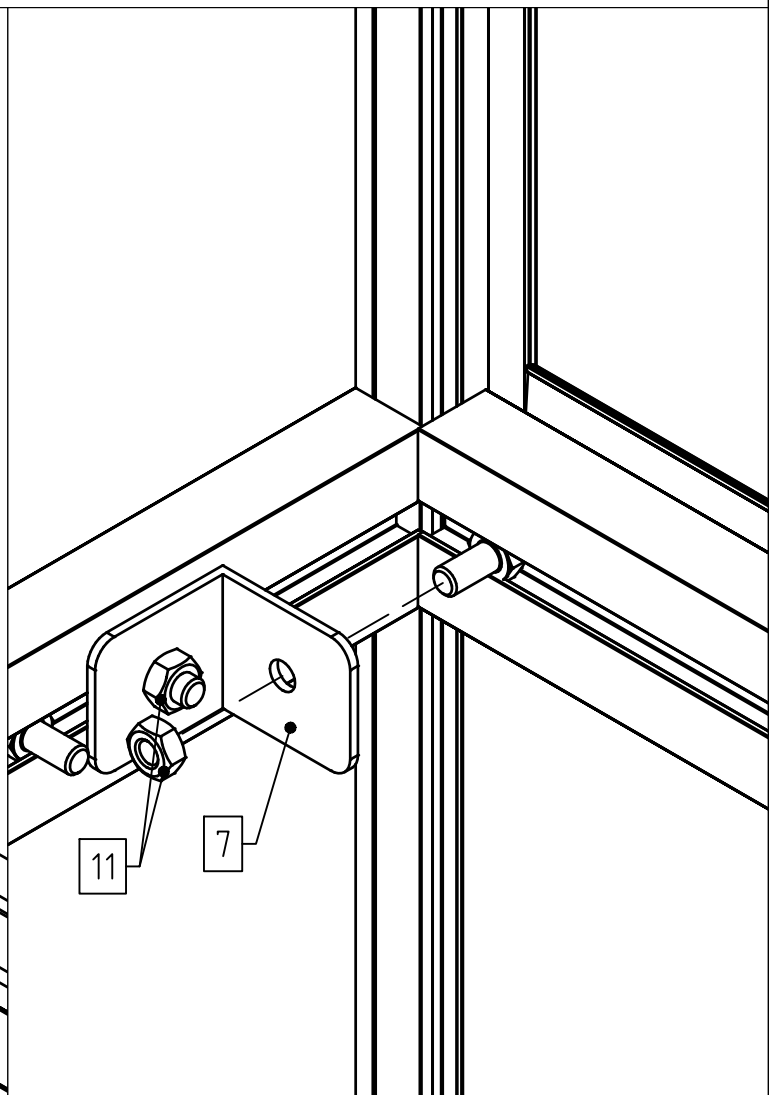
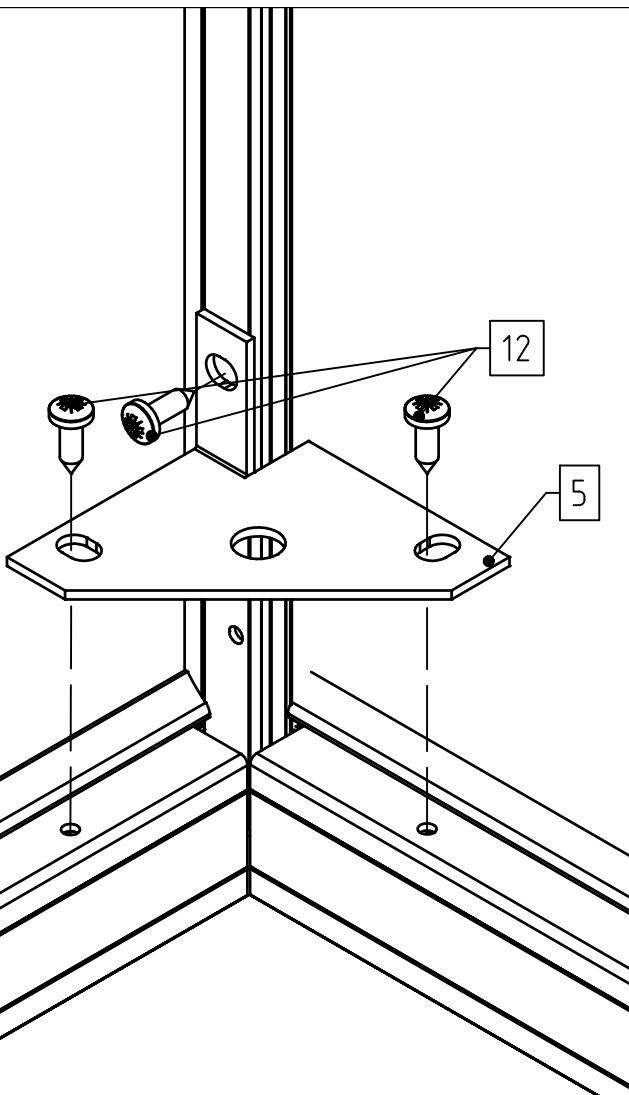
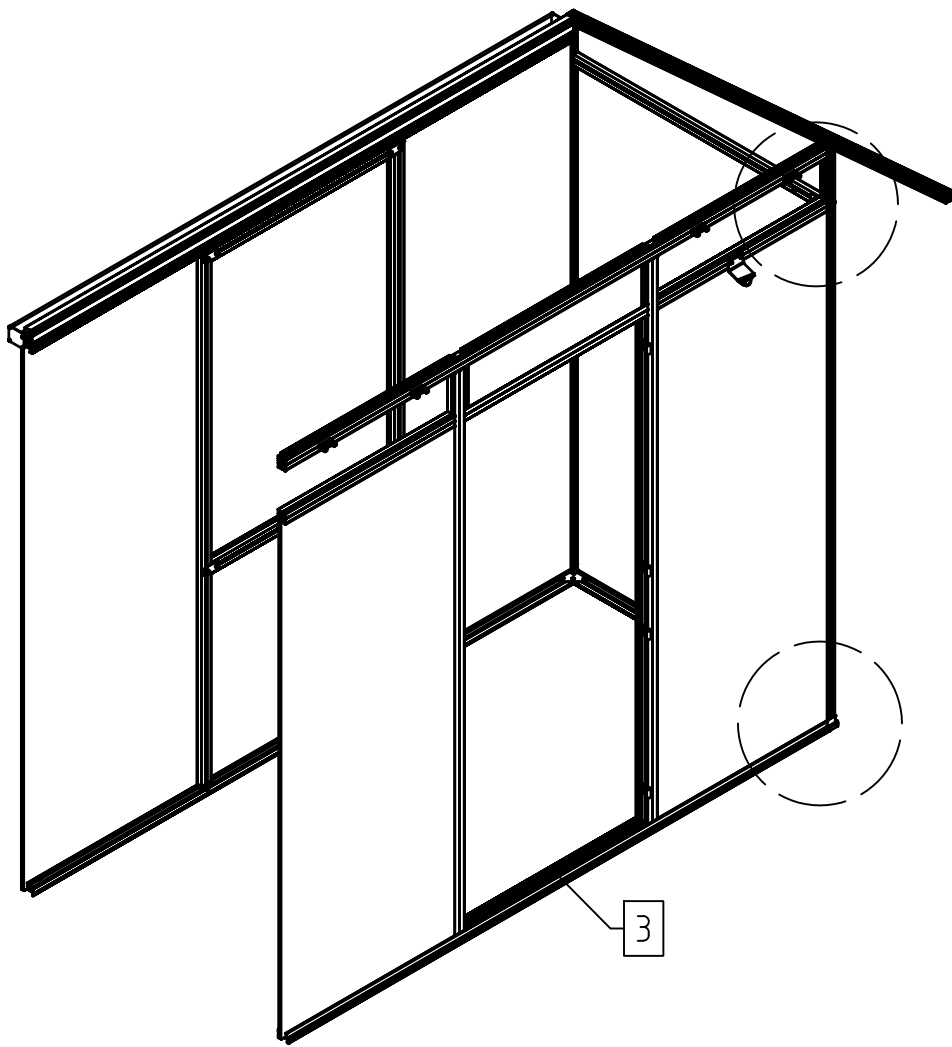

1

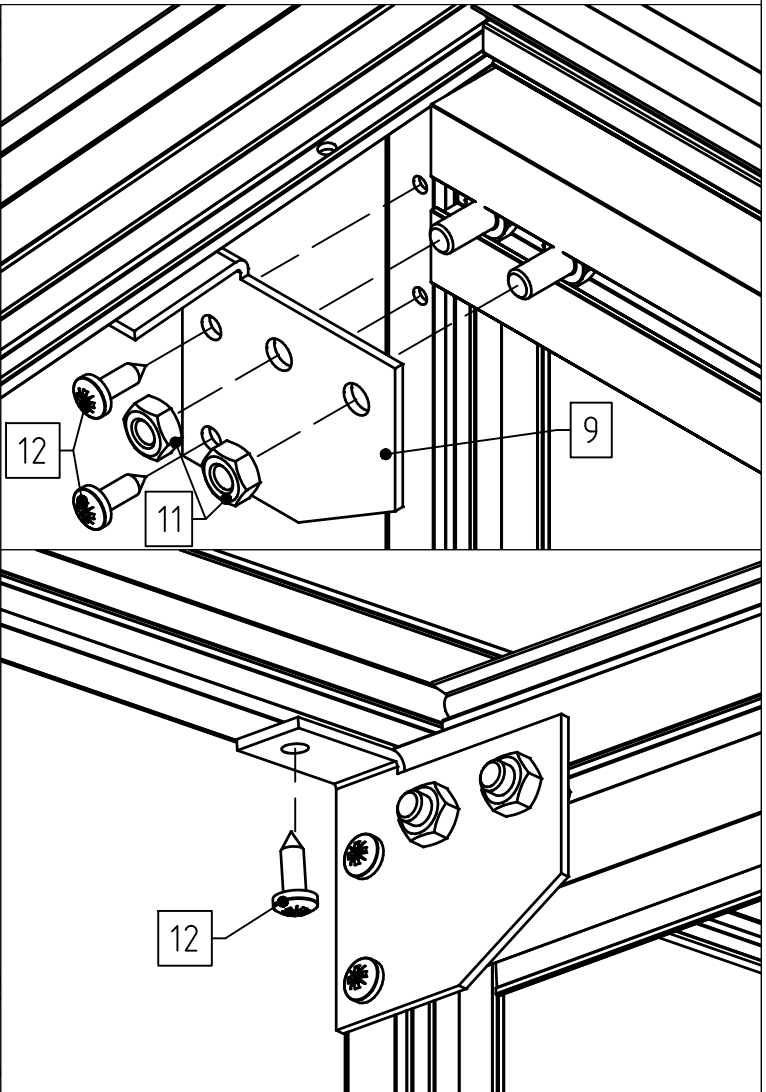
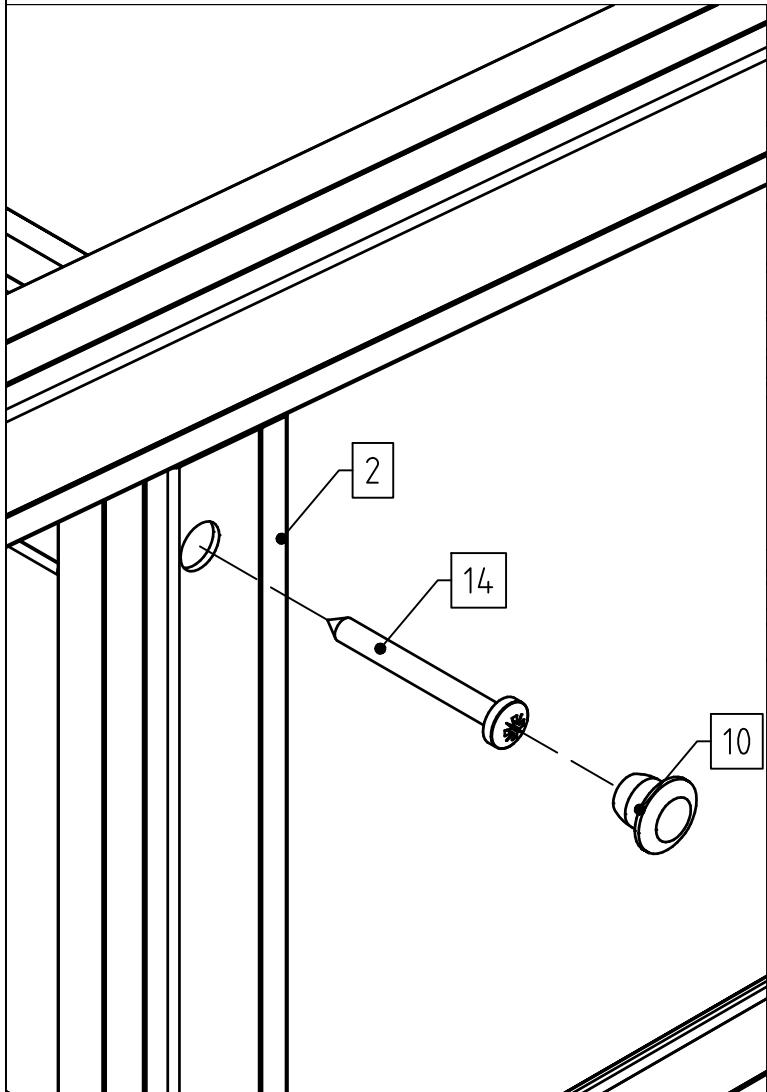
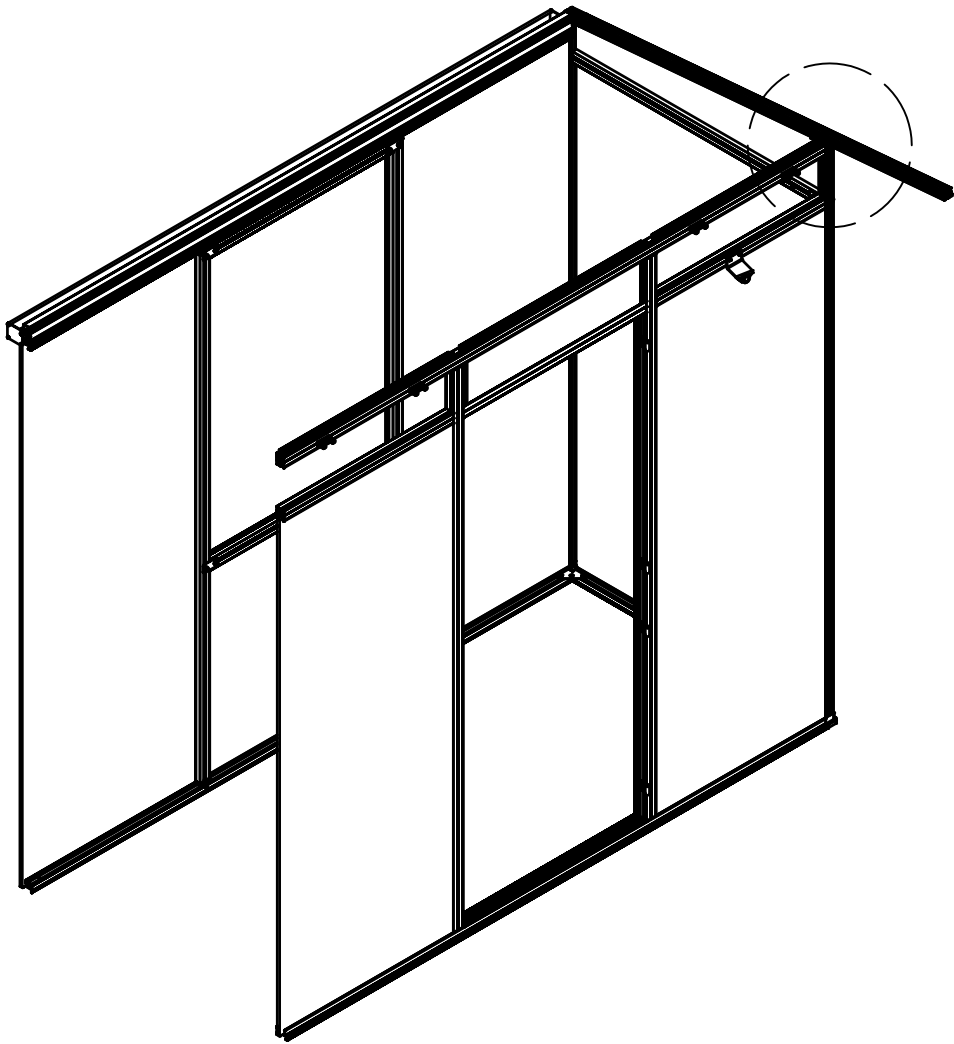

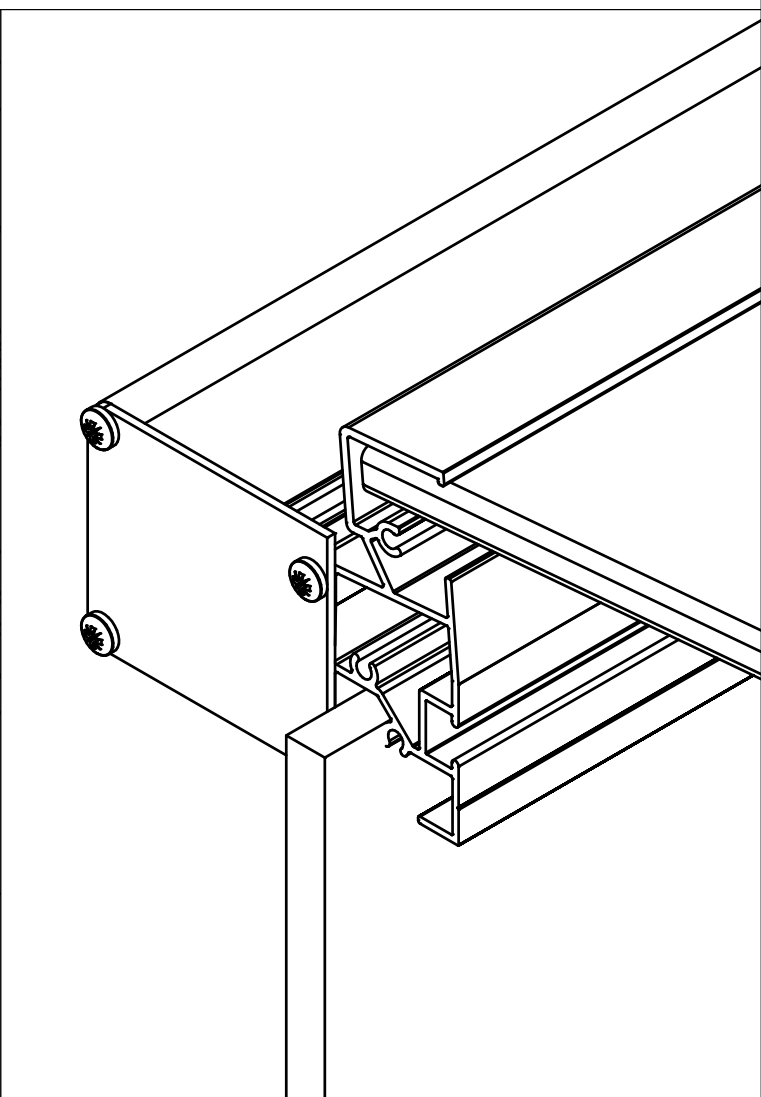
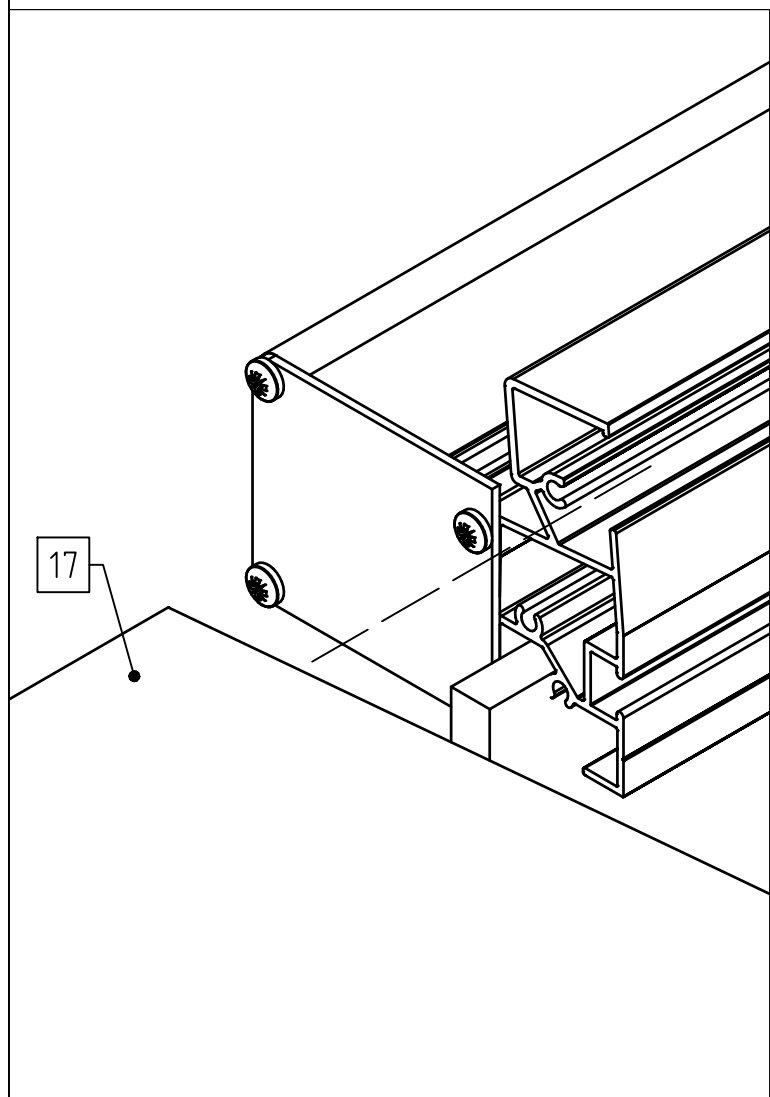
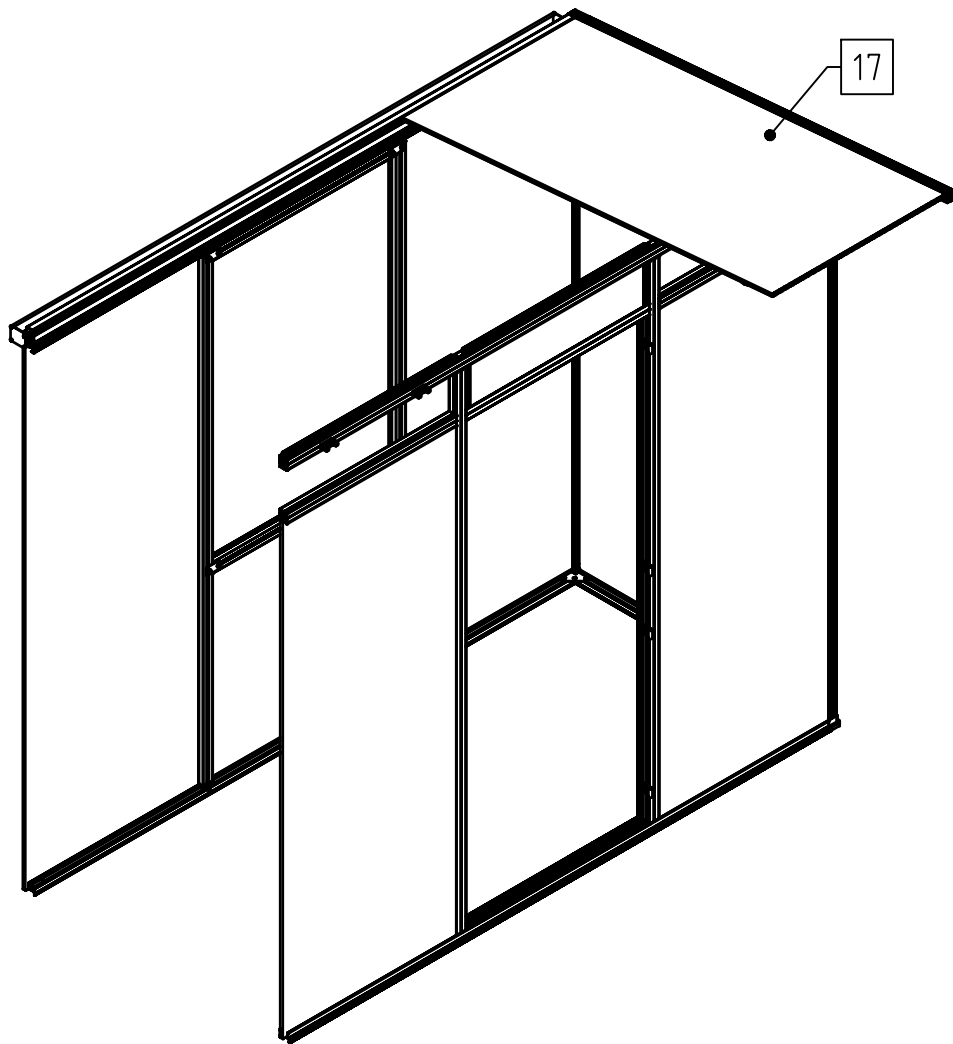

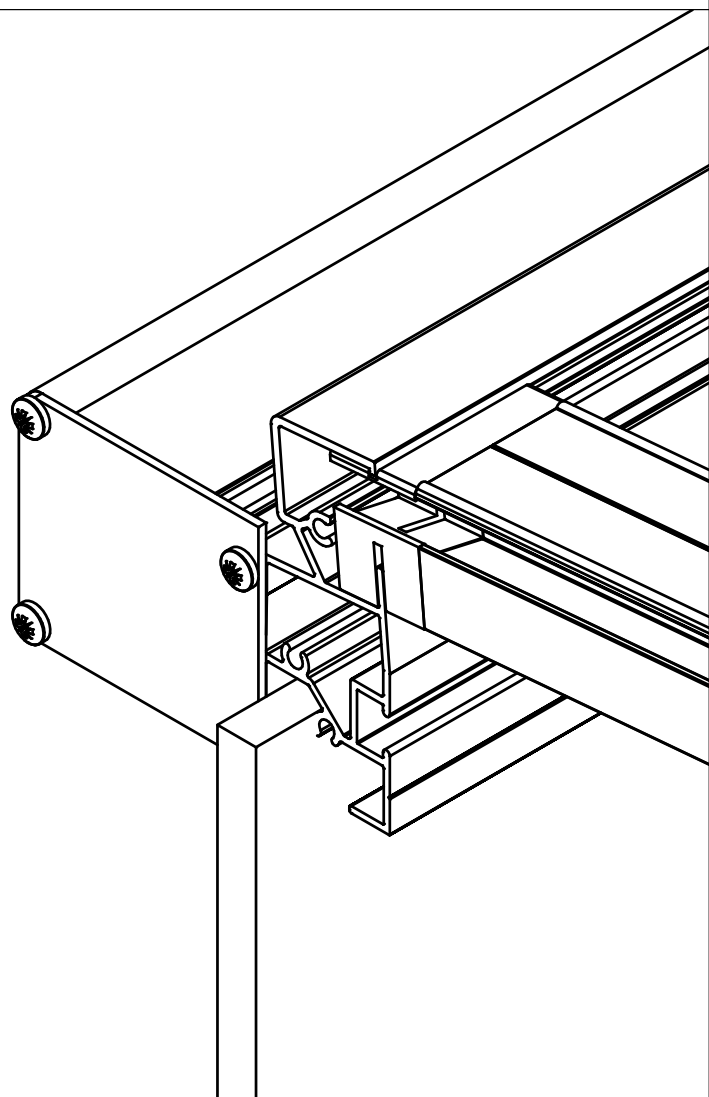
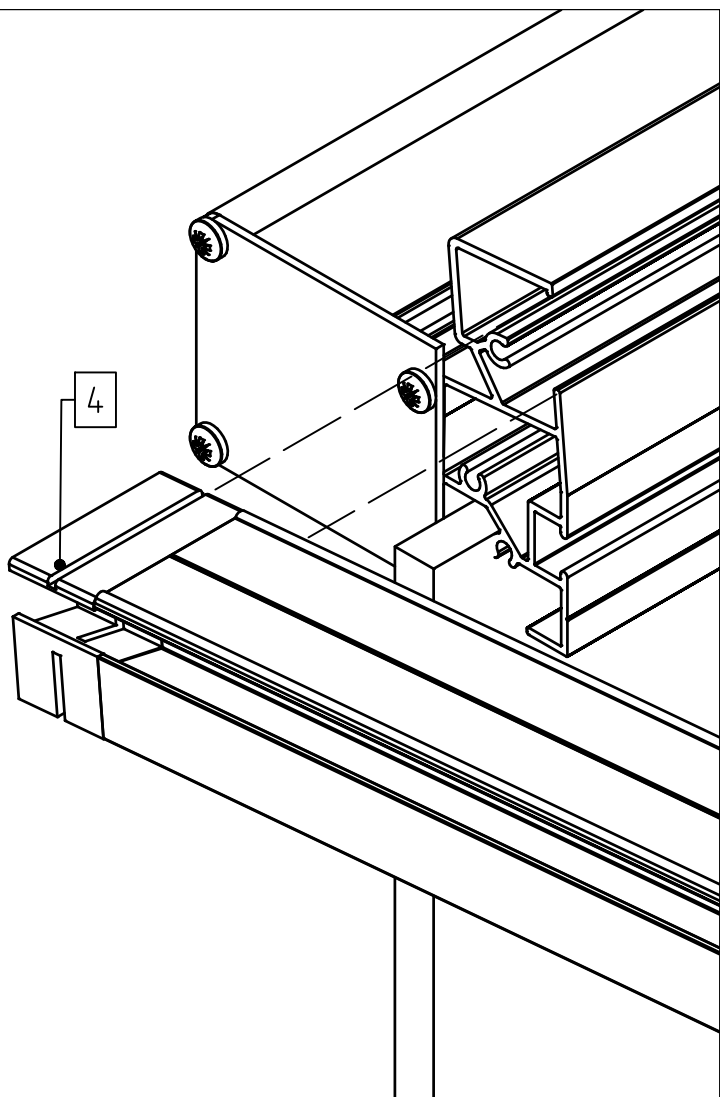
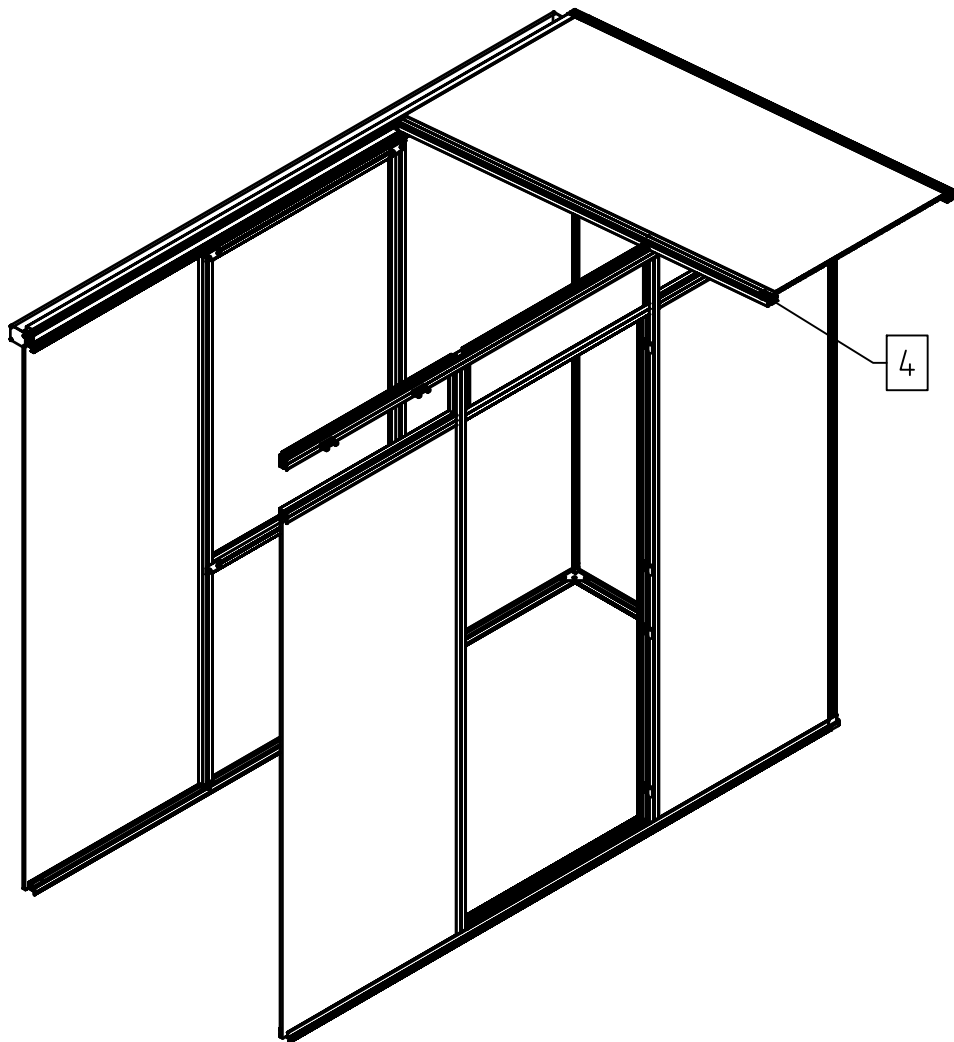

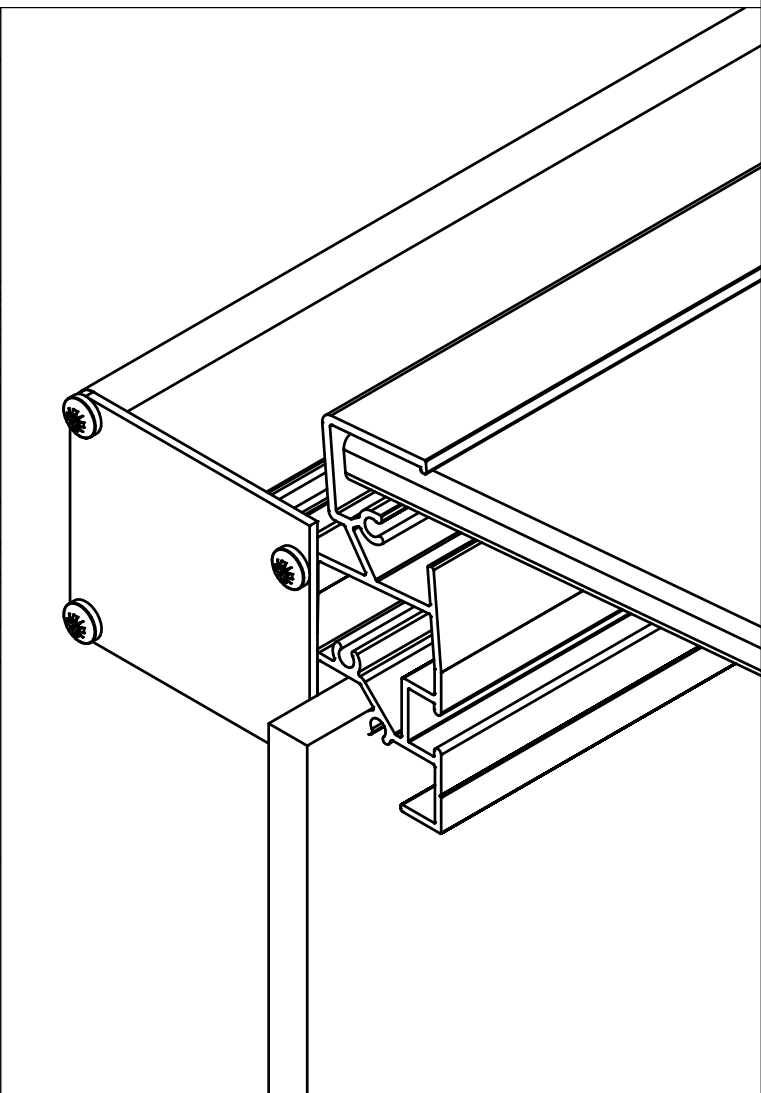
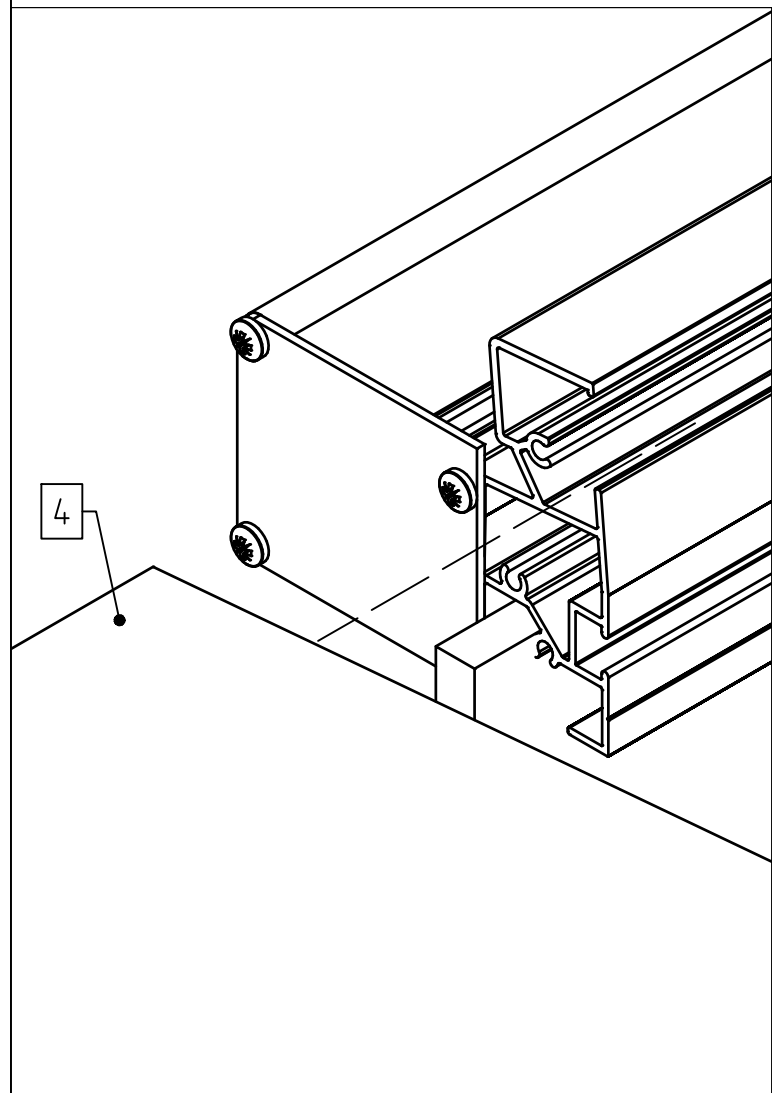
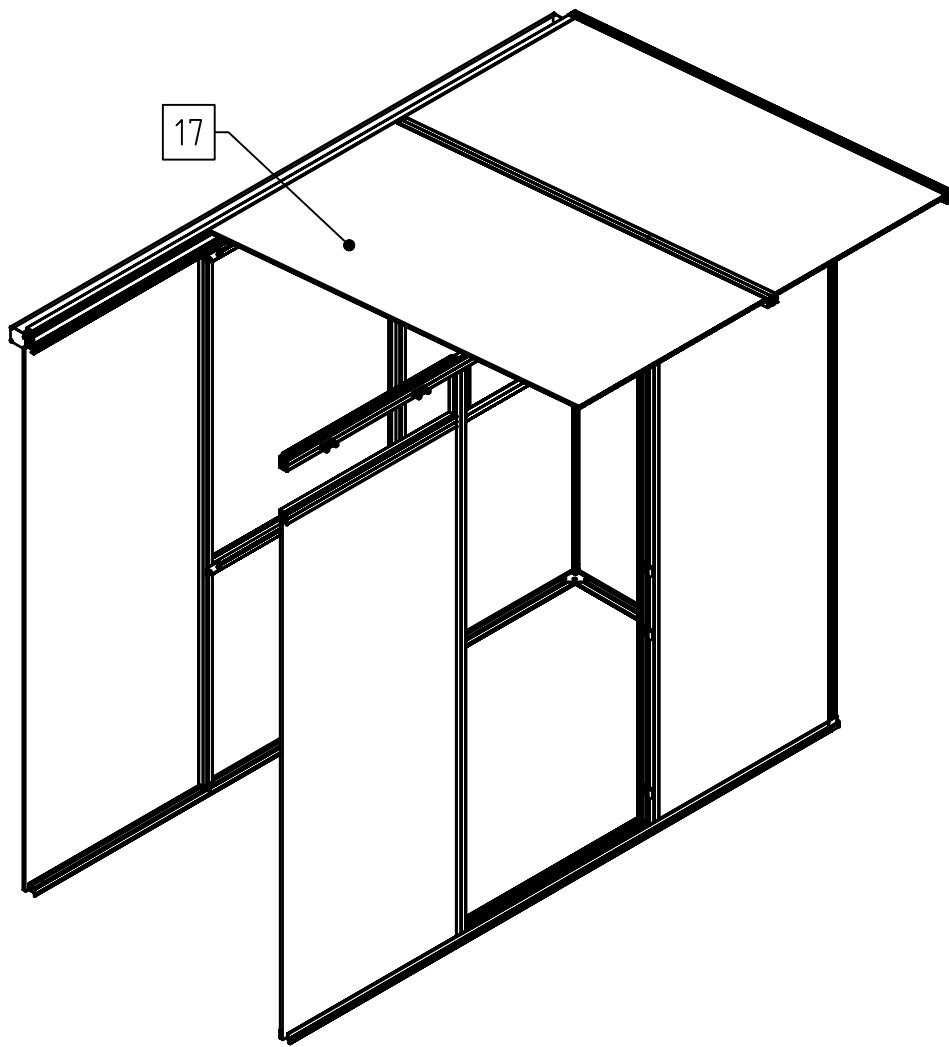

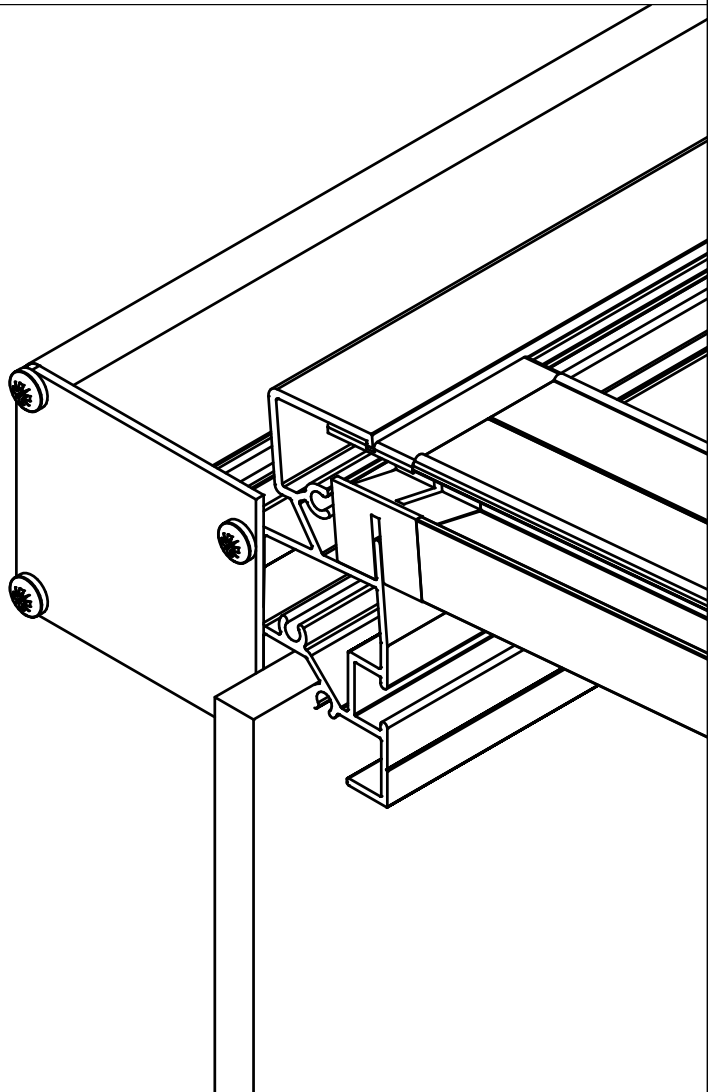
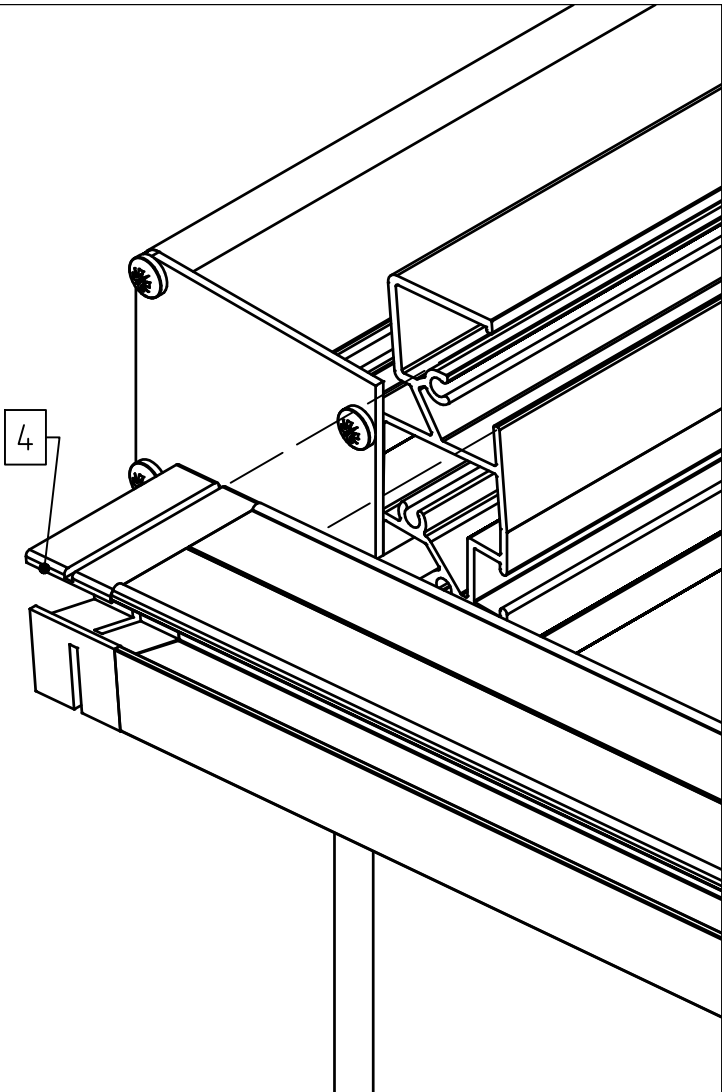
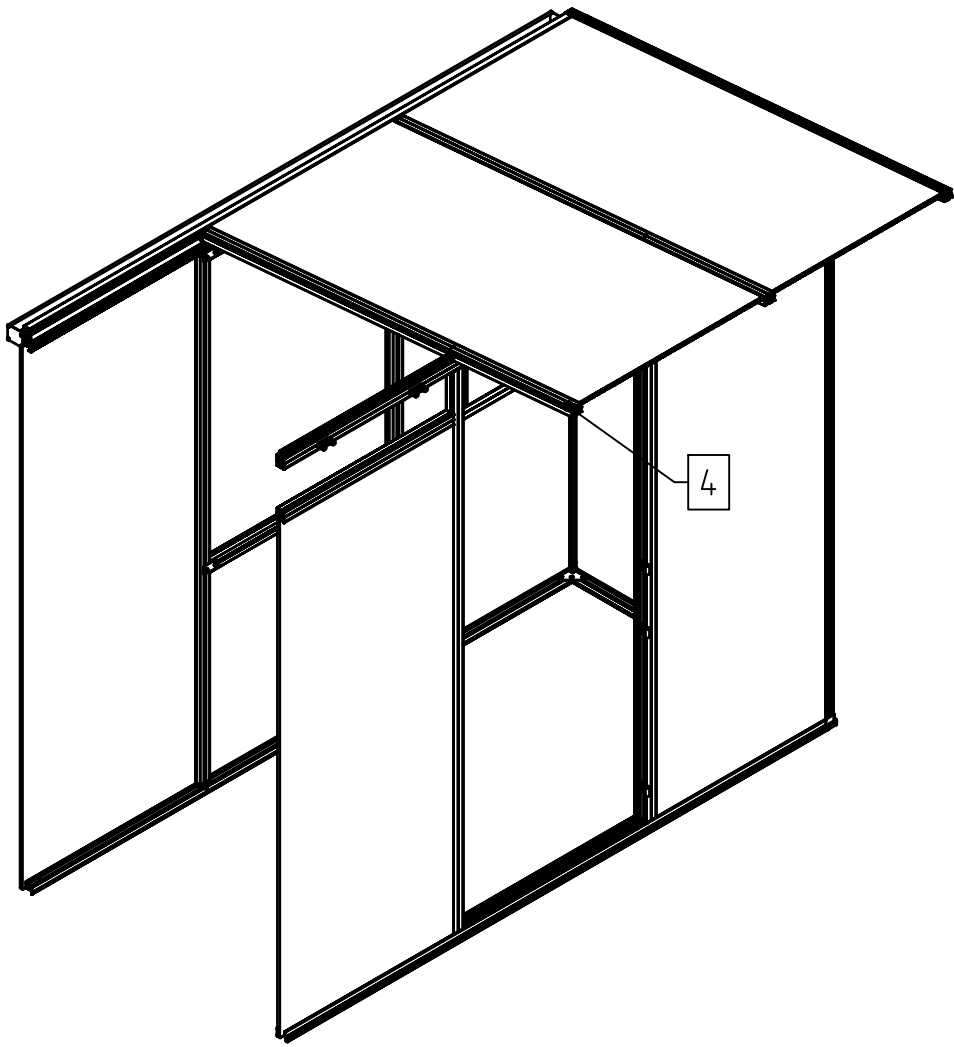

17

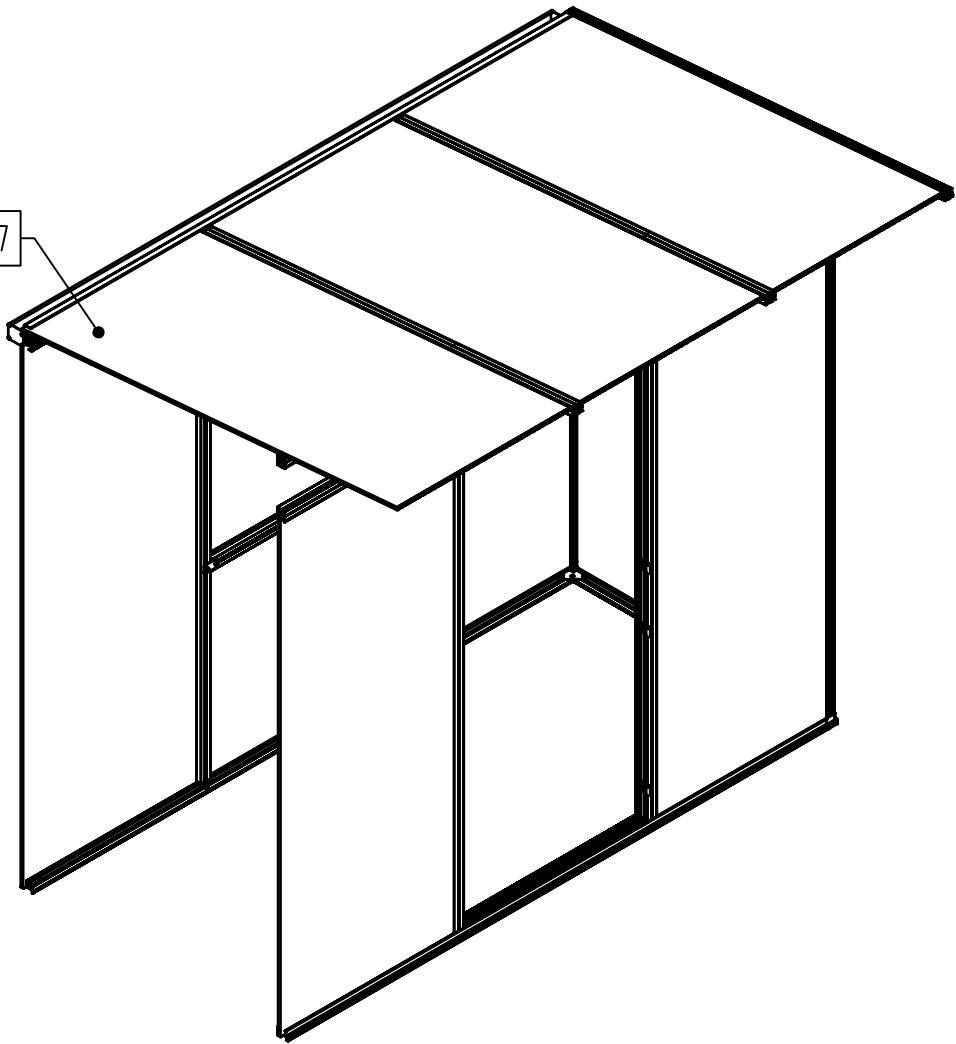

17

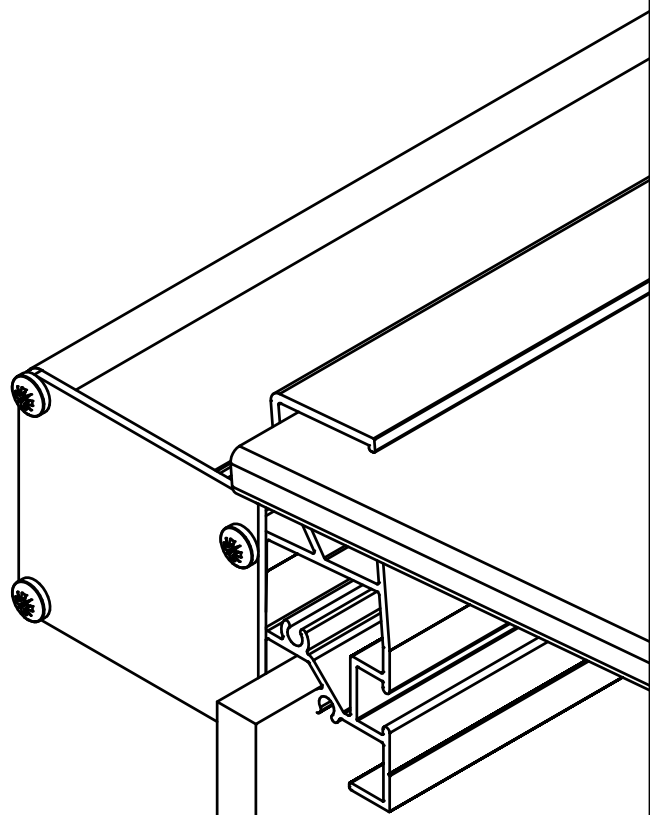
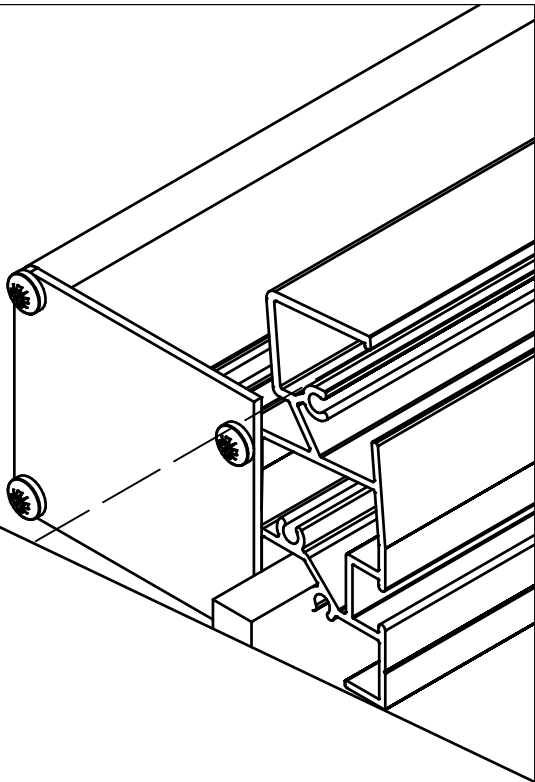

A

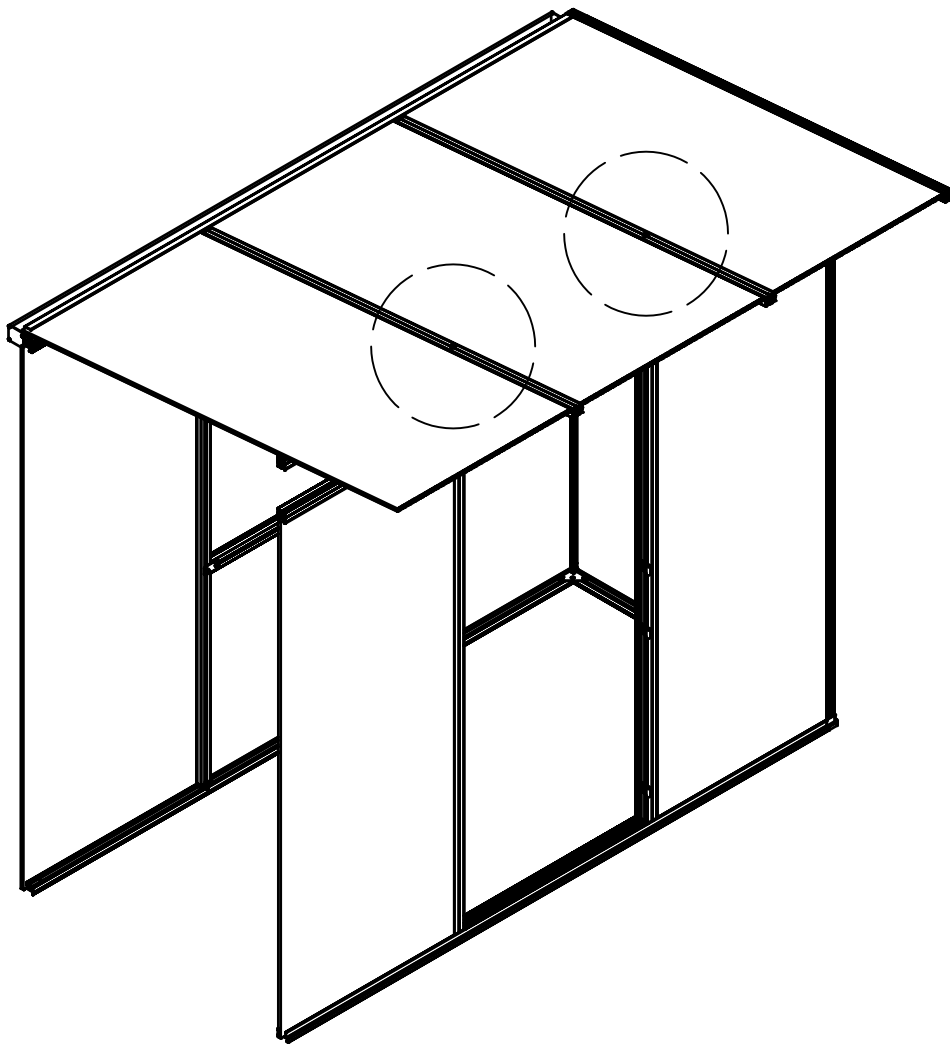

2x

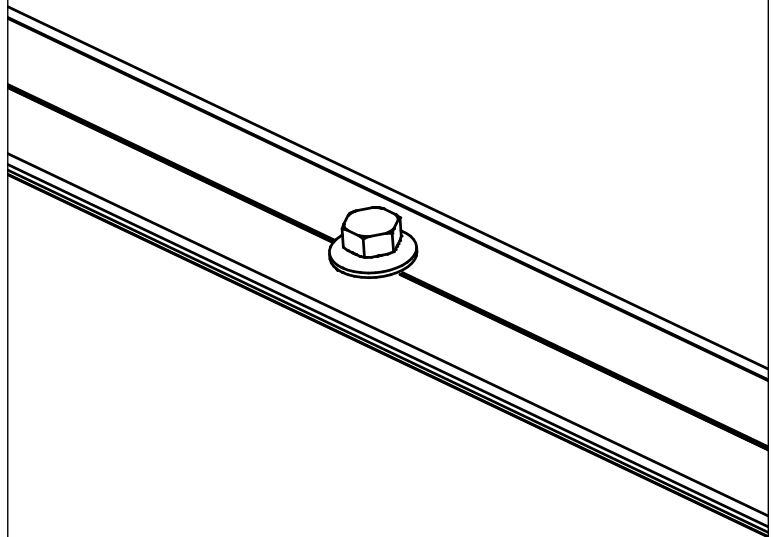
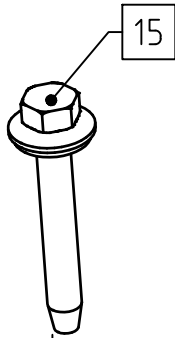

1

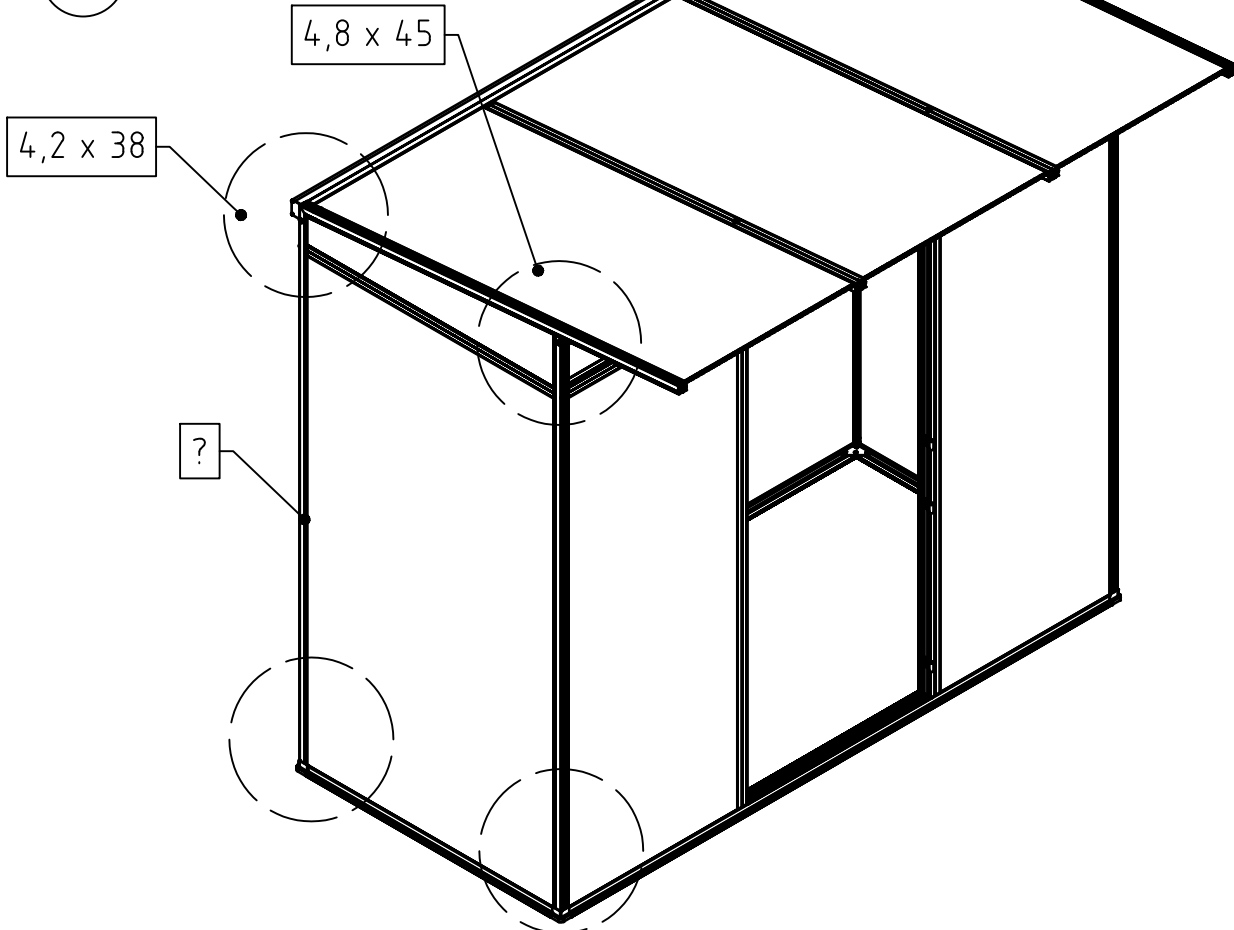

2x

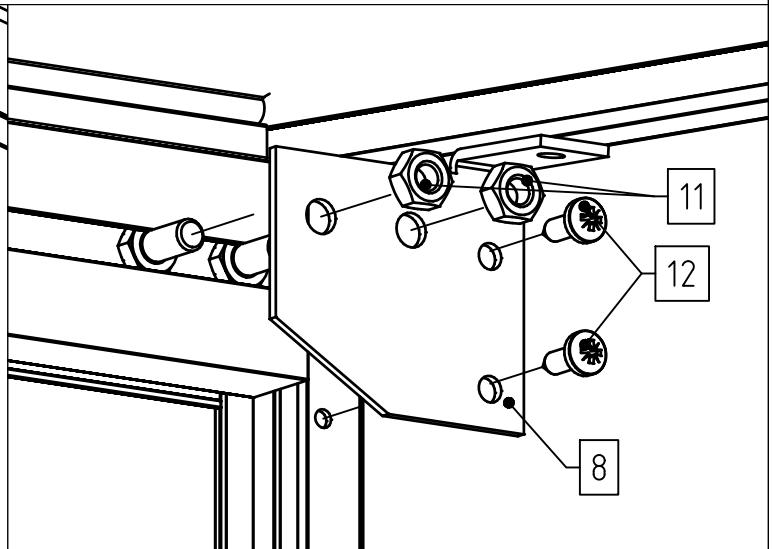
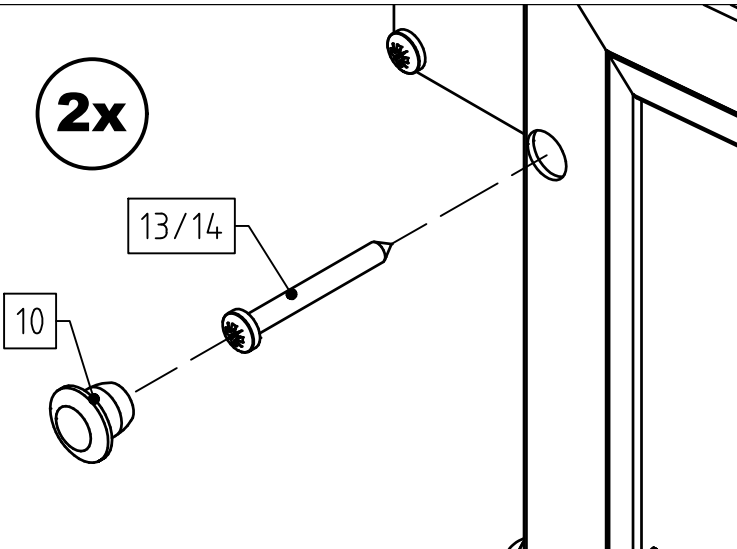



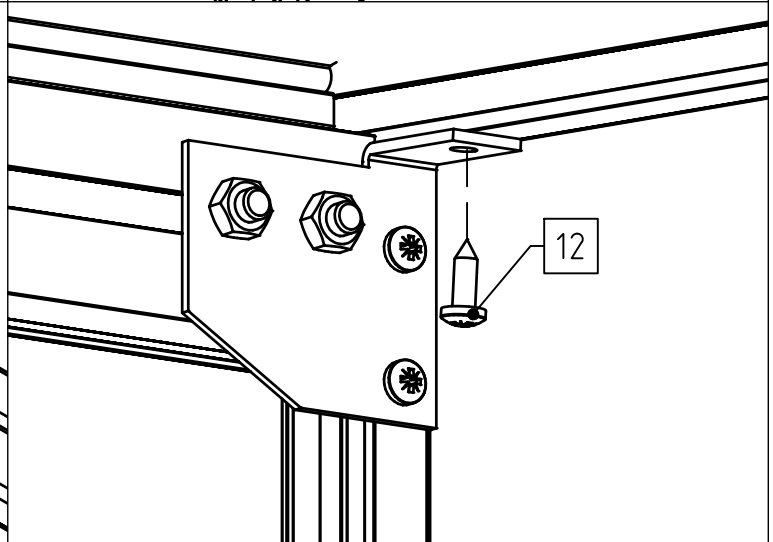
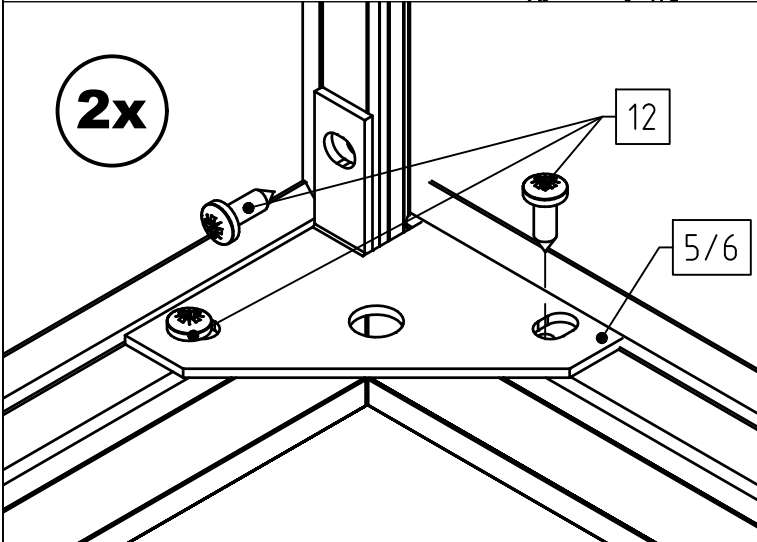

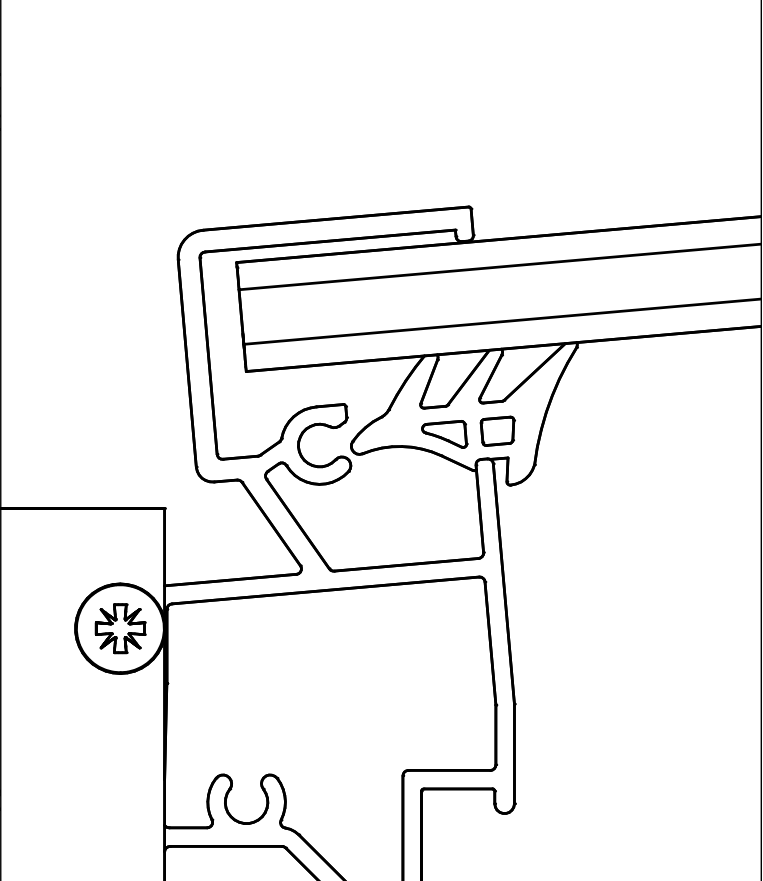
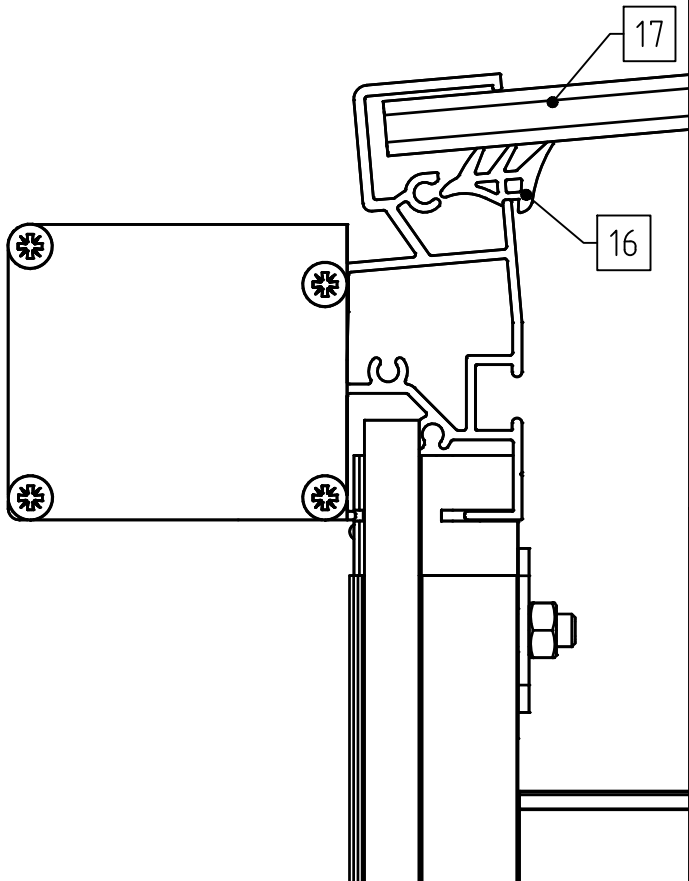
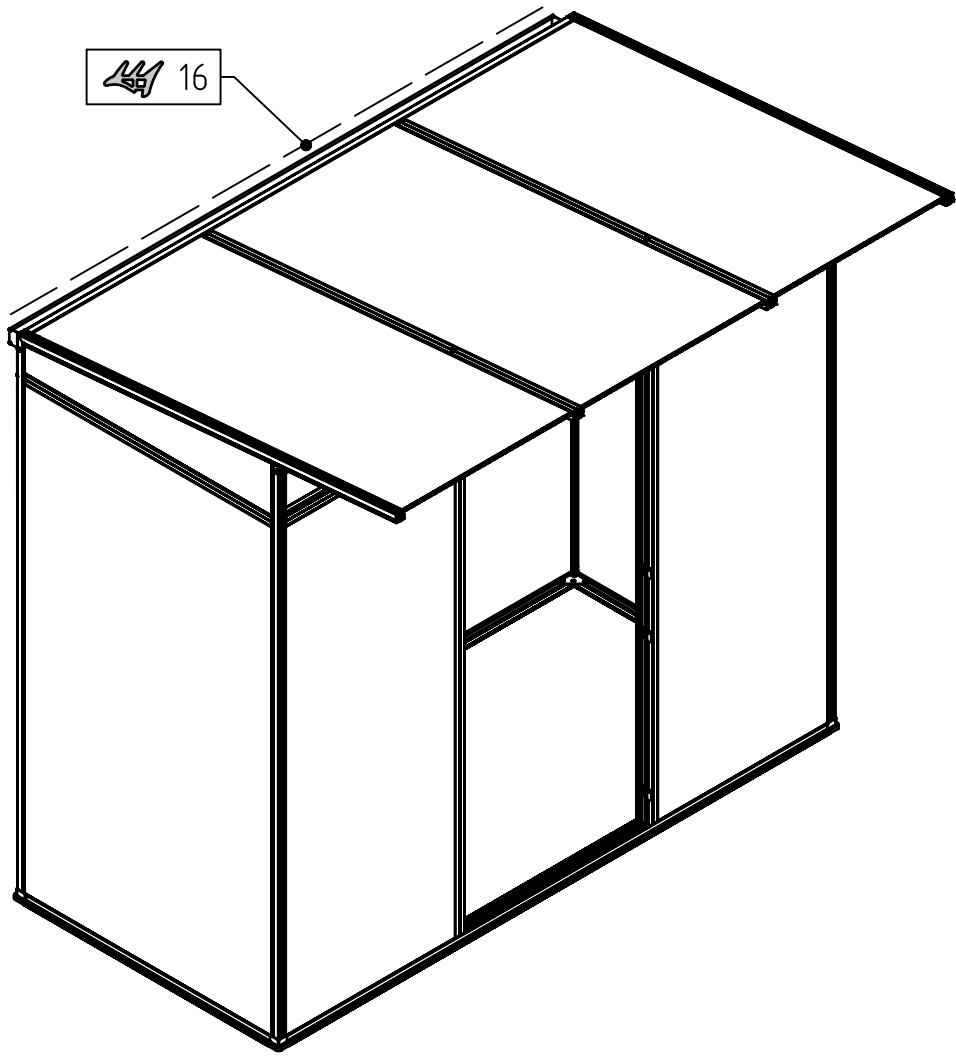



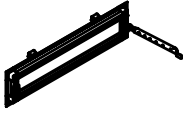

2x





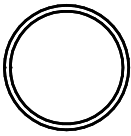
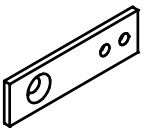



STÜCKLISTE

Endmontage Linea I

Pos.	Abbildung	Art.-Nr.	Bezeichnung	Anzahl	Bemerkung
1			Oberlicht	2	
2			Tür oben	1	
3			Tür unten	1	
4			Rückwandfenster	1	
5		P091-07-01-00-04-1	U-Abschluss 10 mm Rand	2	702 mm
6		P091-08-01-00-04-1	U-Abschluss 10 mm Mitte	1	758 mm
7		P026-03-01-00-00-1	Abdeckwinkel 50 x 20 x 2 mm	1	2303 mm
8		P075-02-01-00-00-1	Fallrohr Ø32 mm	1	1800 mm
9		9999000475	Fallrohr- befestigungsplatte	1	
10		9999000615	Fixierdorn	2	
11		9999000520	Scharnierbolzen Ø6 x 90 mm	4	
12		9999000358	Scharnierbolzen	6	52 mm

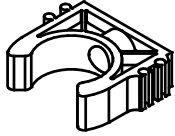
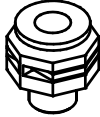
STÜCKLISTE

Endmontage Linea I

Pos.	Abbildung	Art.-Nr.	Bezeichnung	Anzahl	Bemerkung
13		9999000027	Fallrohrhalter	1	
14		9999000216	Rinnenablaufschraubbar	1	
15		9999000128	Sechskantmutter M6	4	DIN 934
16		9999001984	Linsenkopfschraube 4,8 x 9,5	2	DIN 7981
17		9999000144	Linsenkopfschraube 4,2 x 13	4	DIN 7981
18		9999000474	Senkschraube M6 x 16	1	DIN 965
19					
20					
21					
22					
23					
24					

A

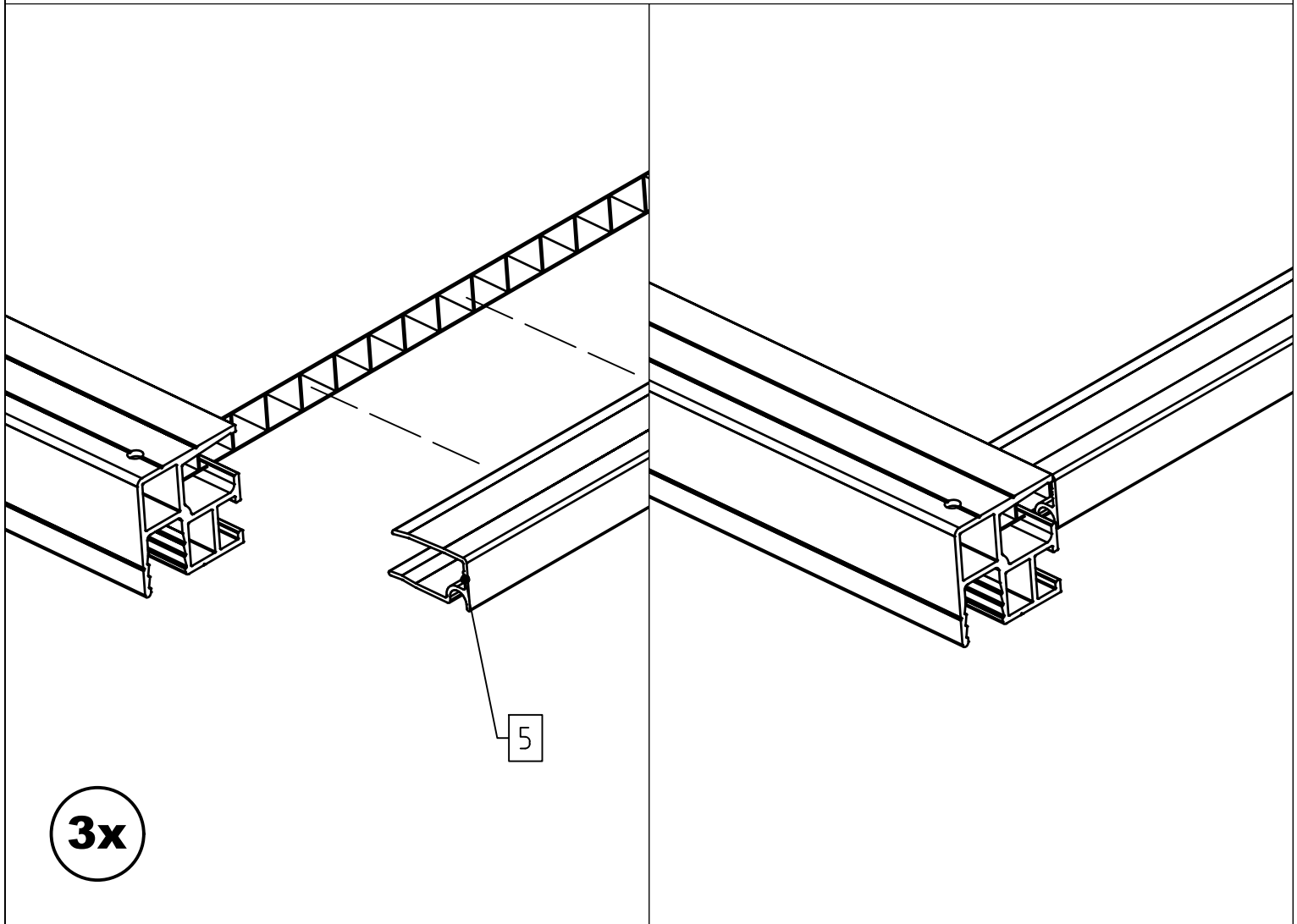
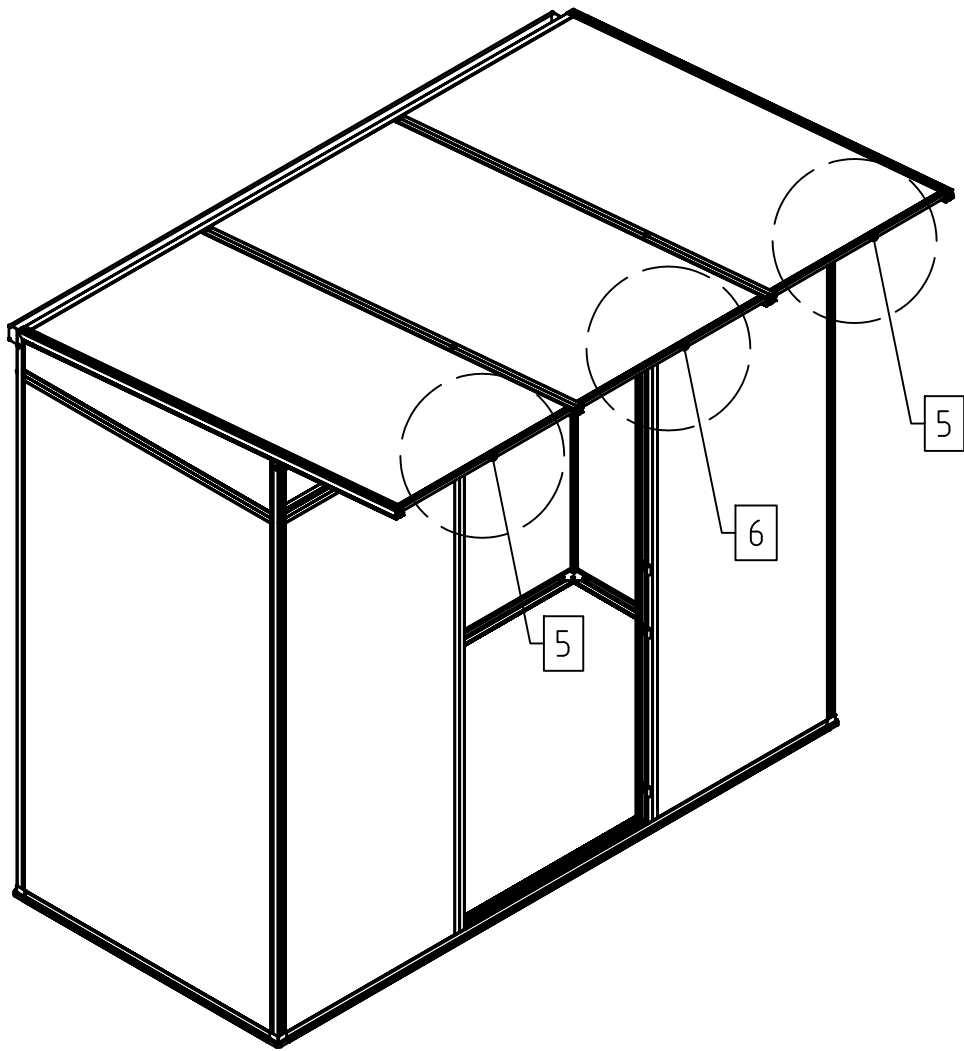

A

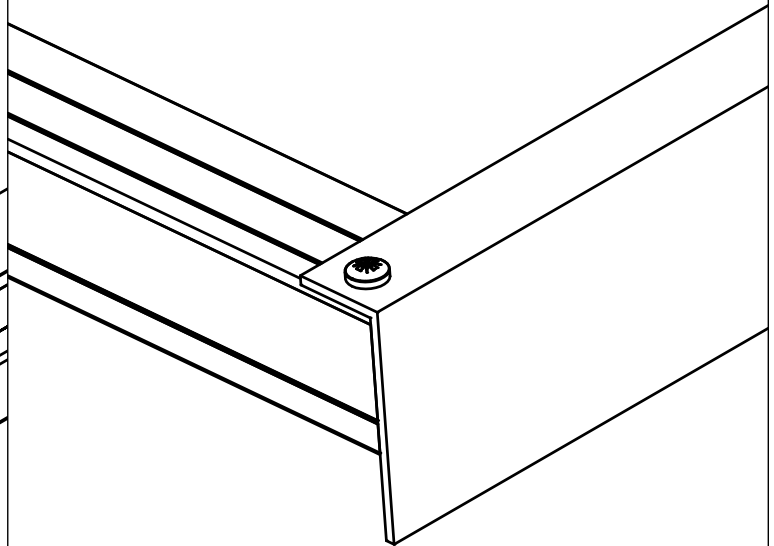
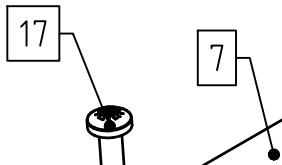
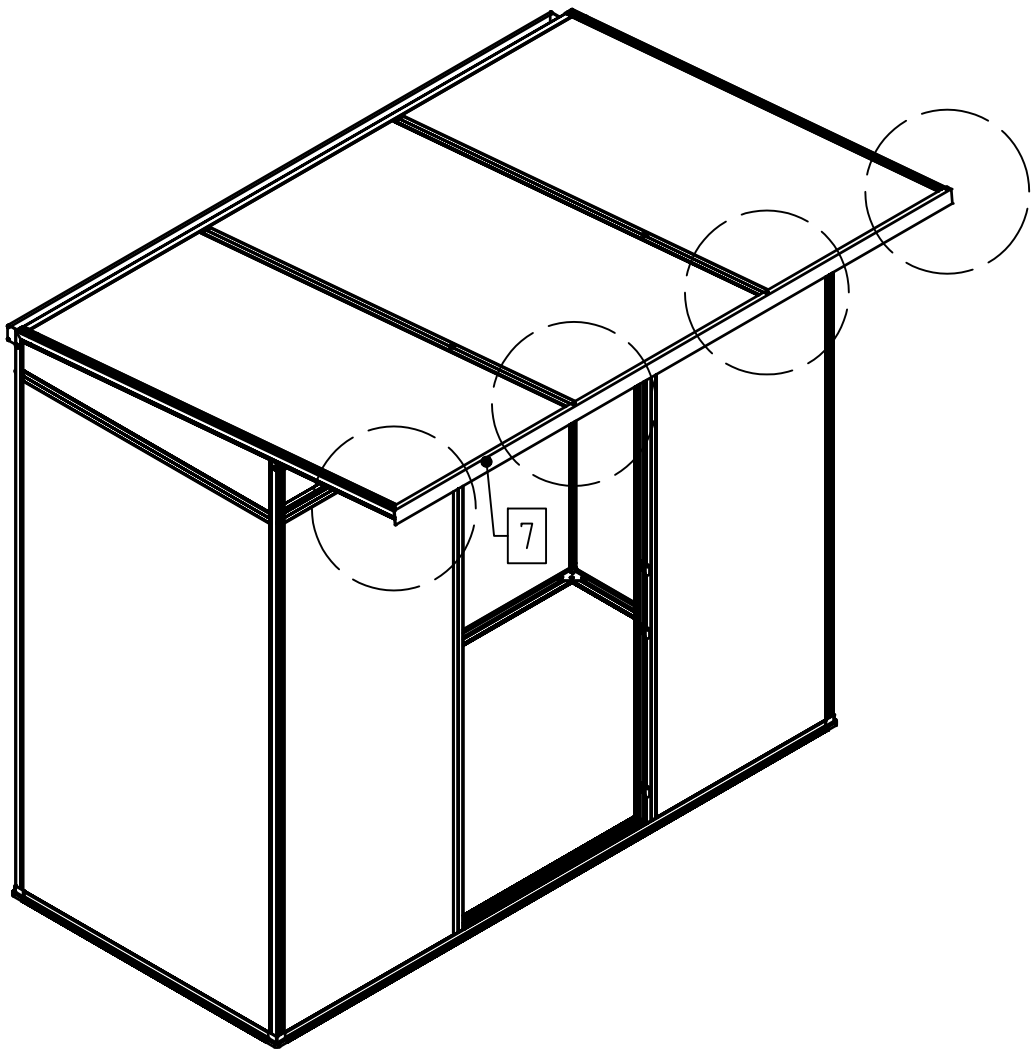

4x

A



VD

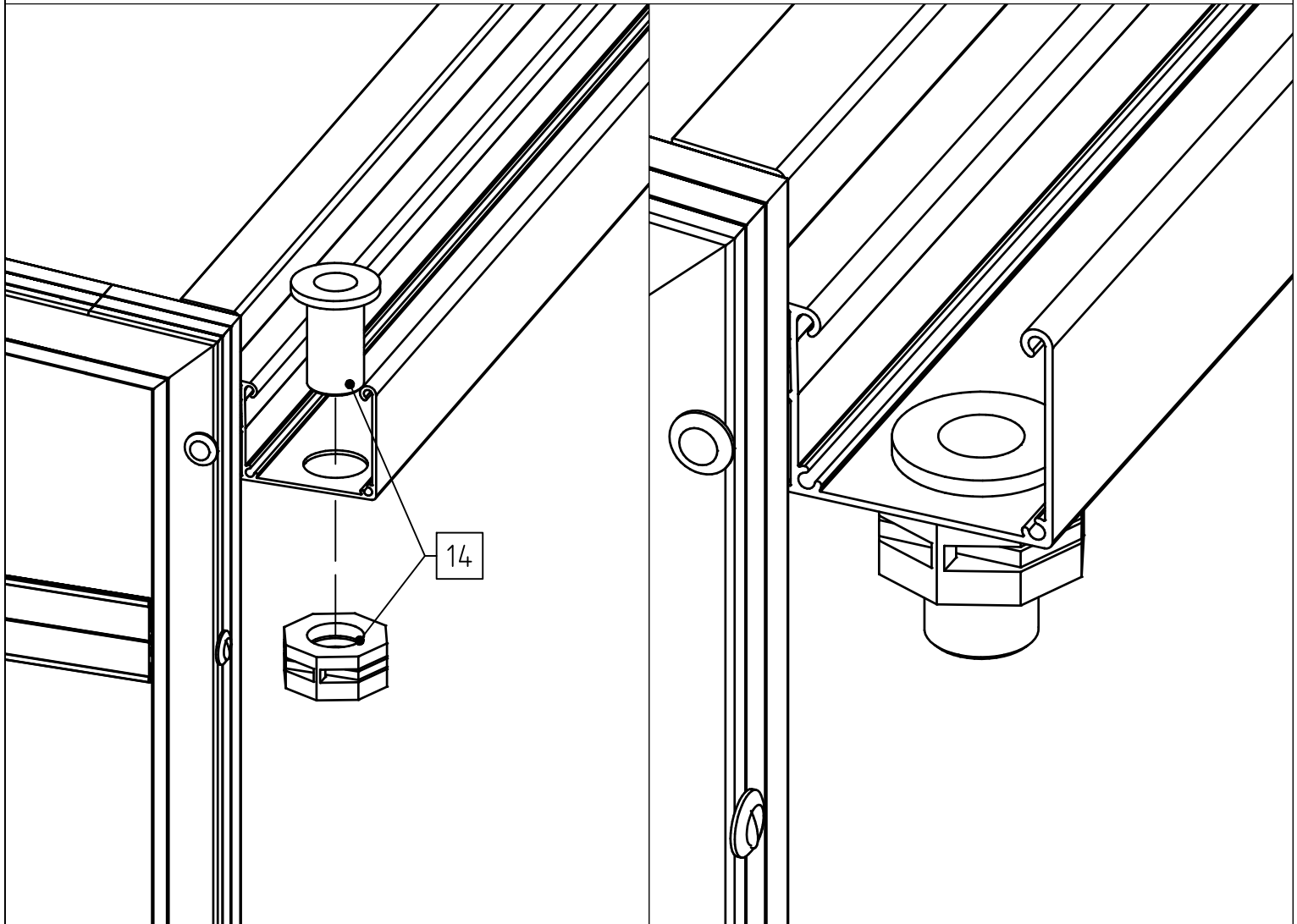
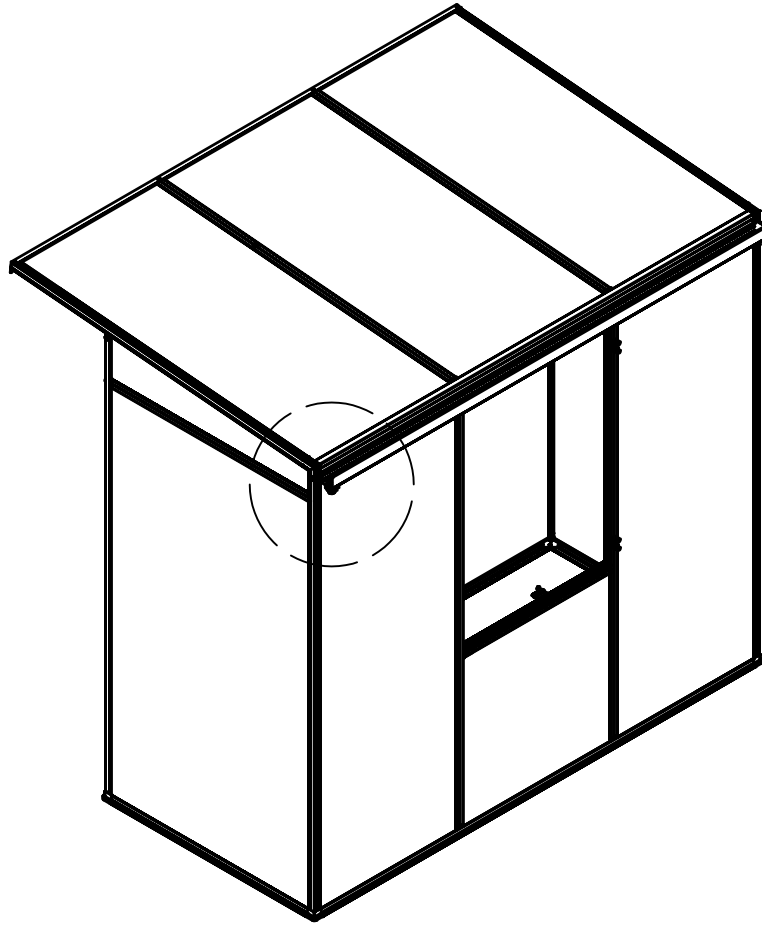

A

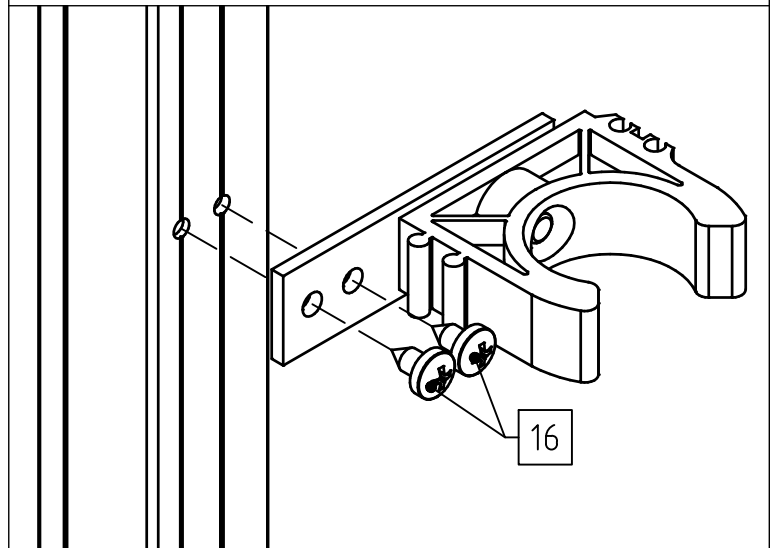
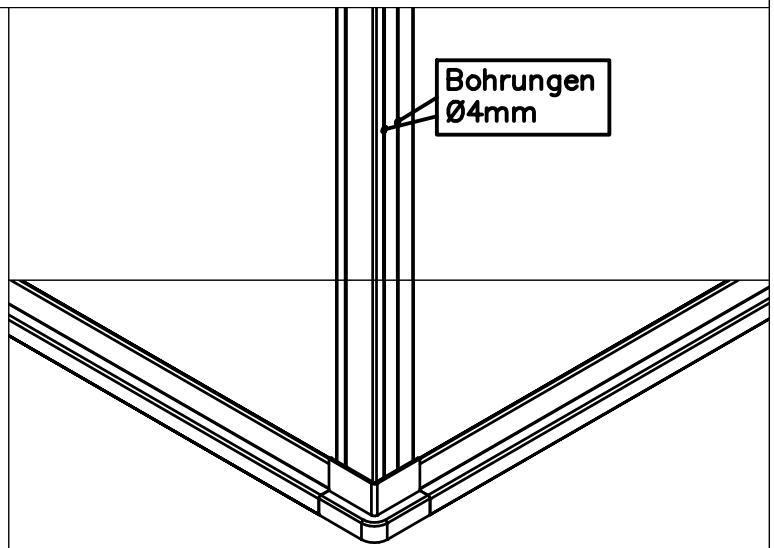
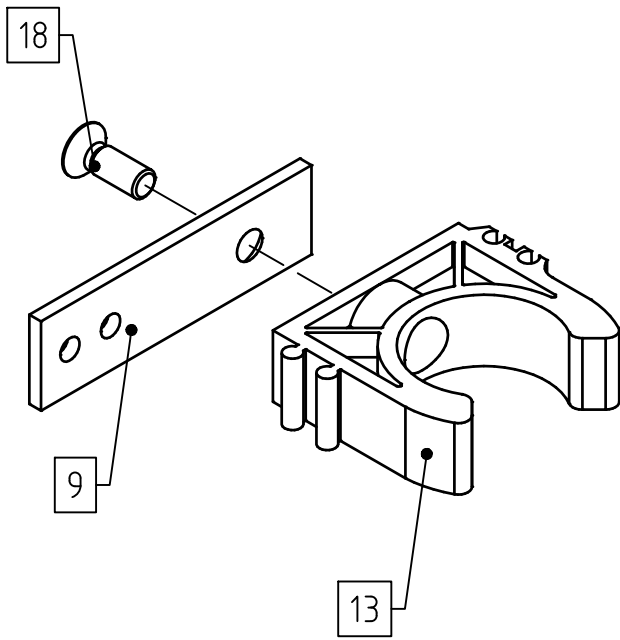
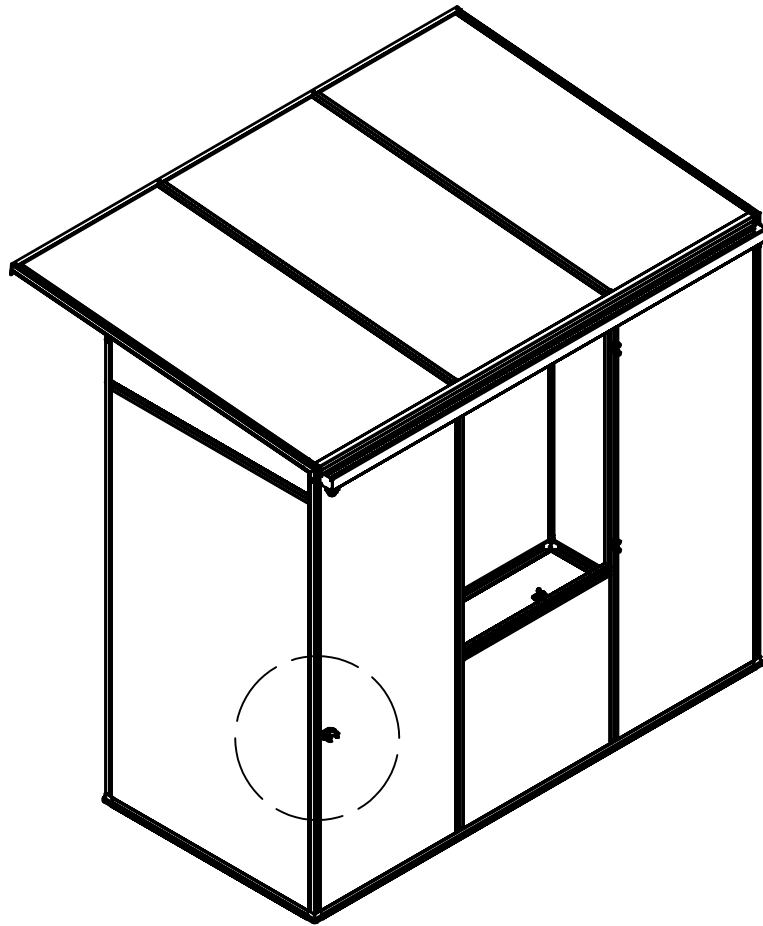

A

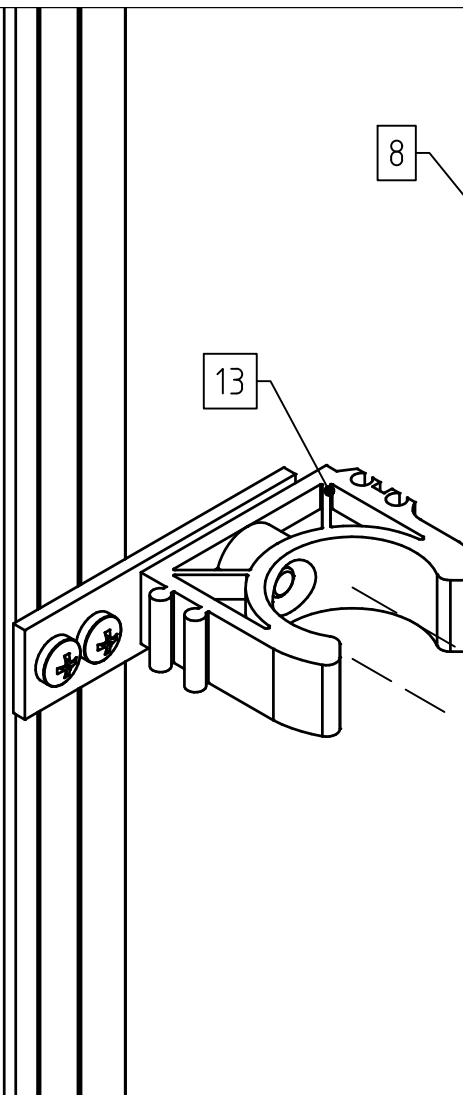
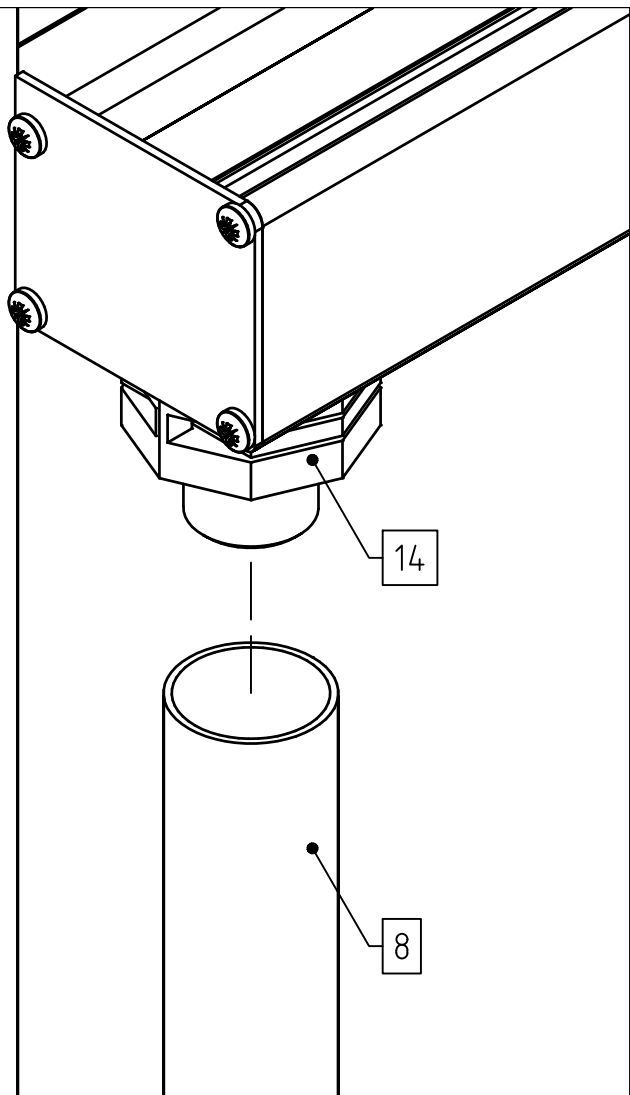
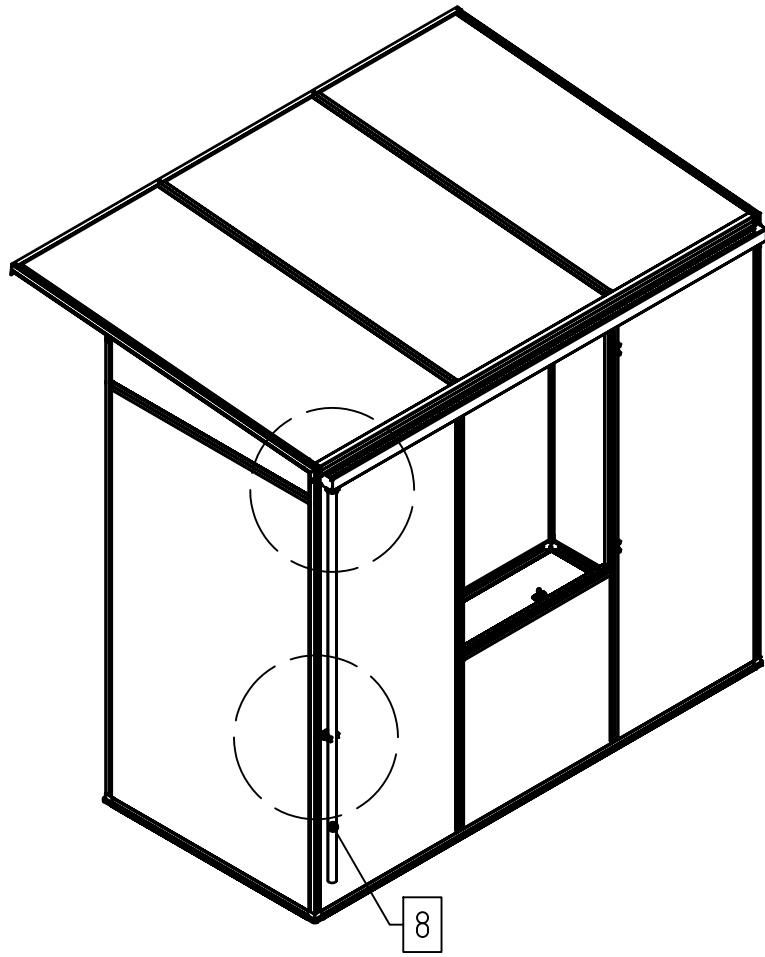

I

VD

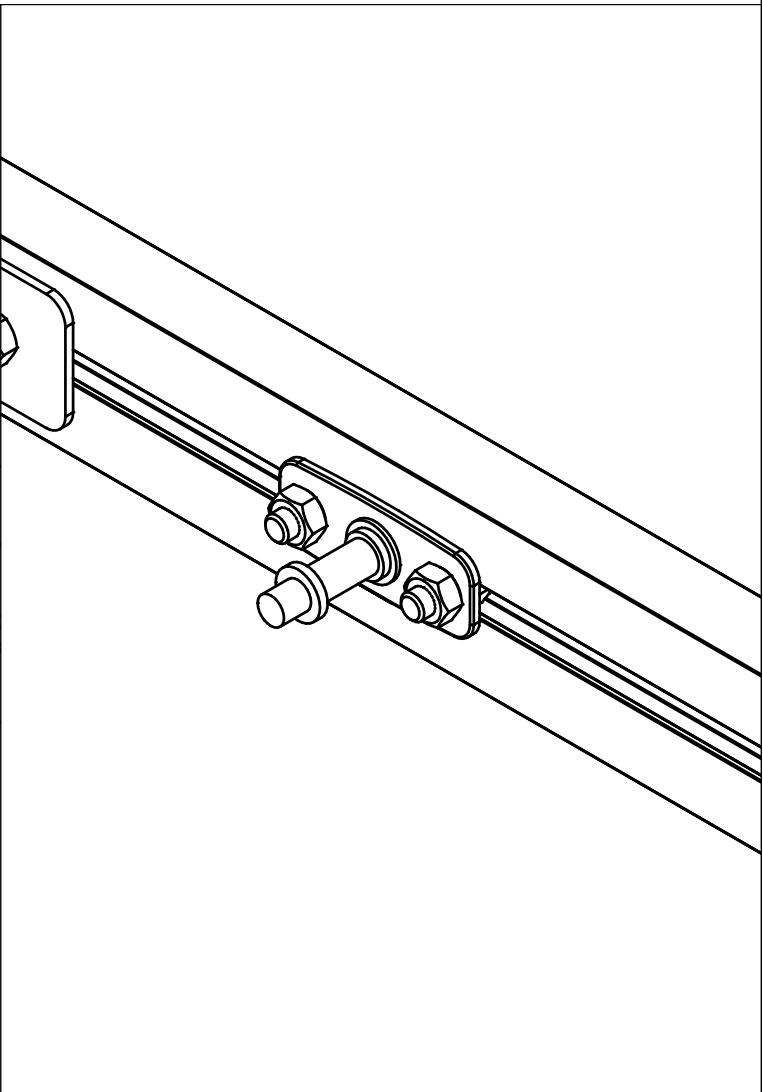
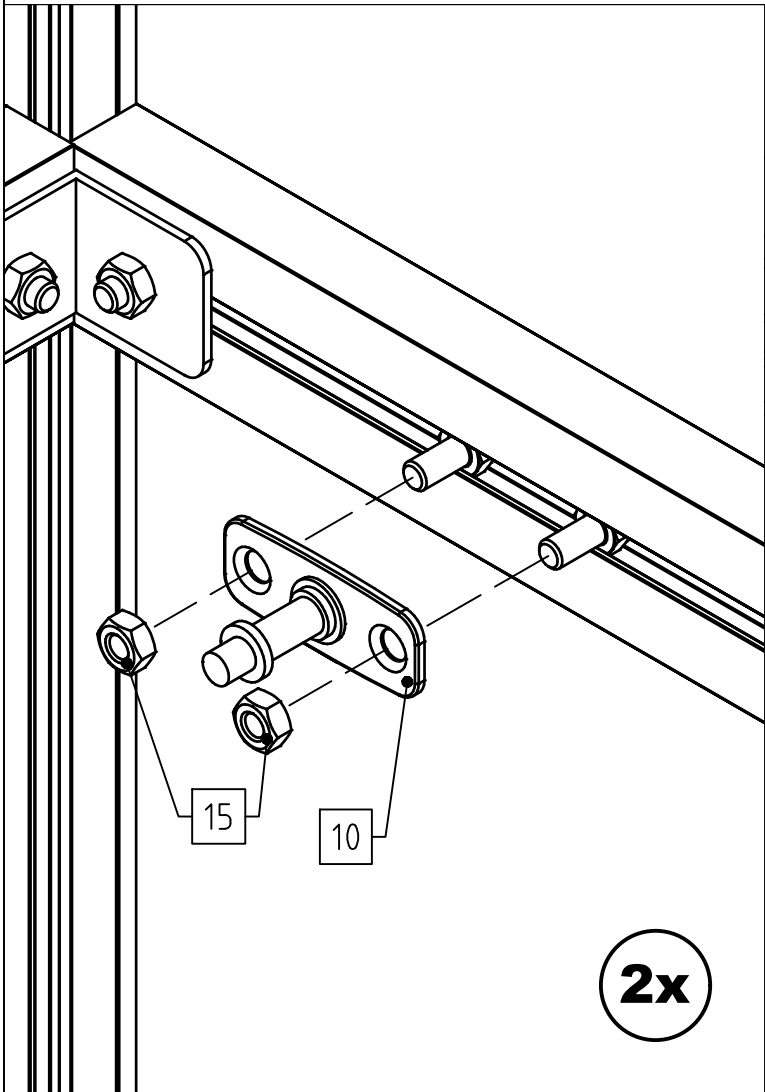
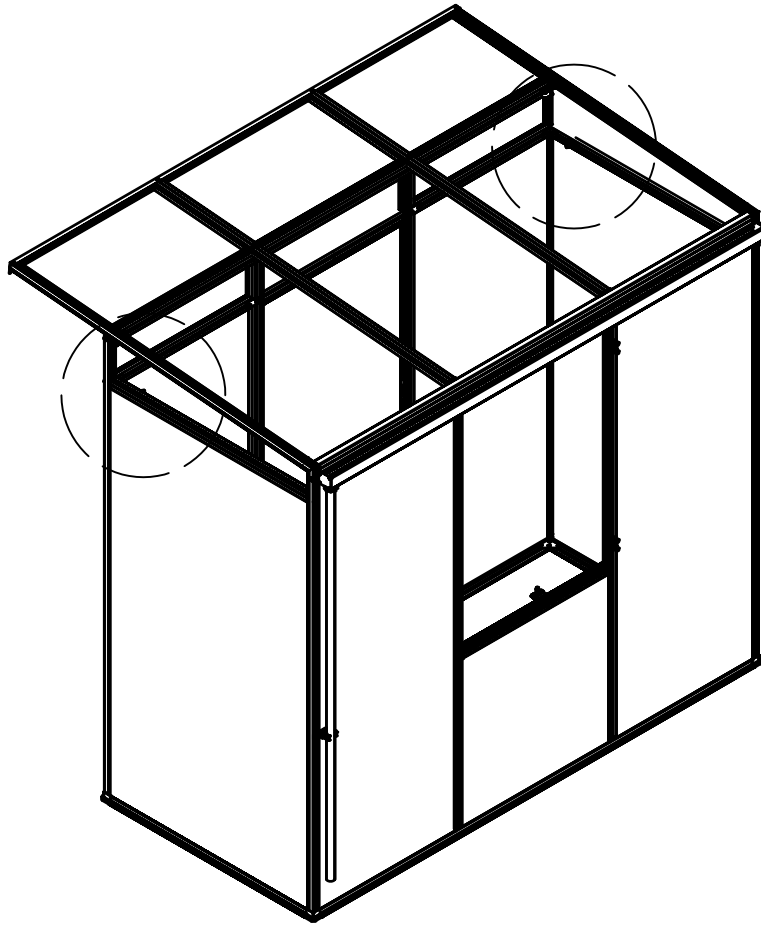

A

VD

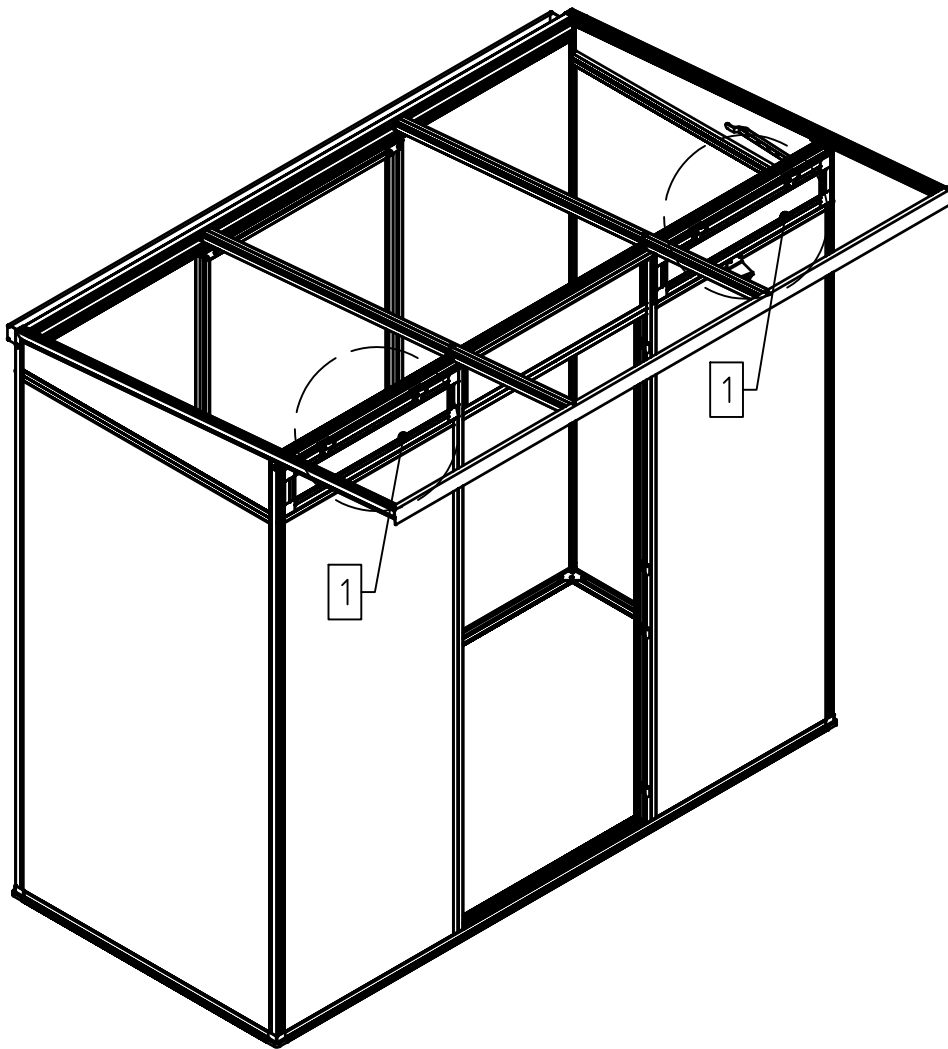

2x

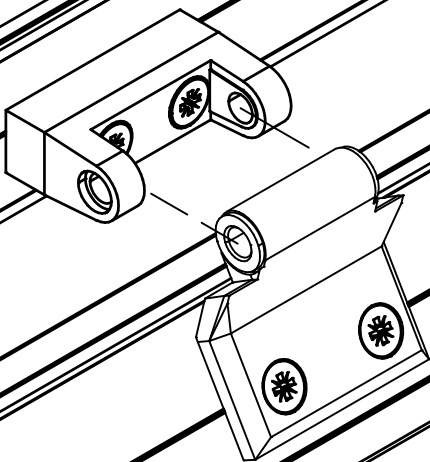

4x

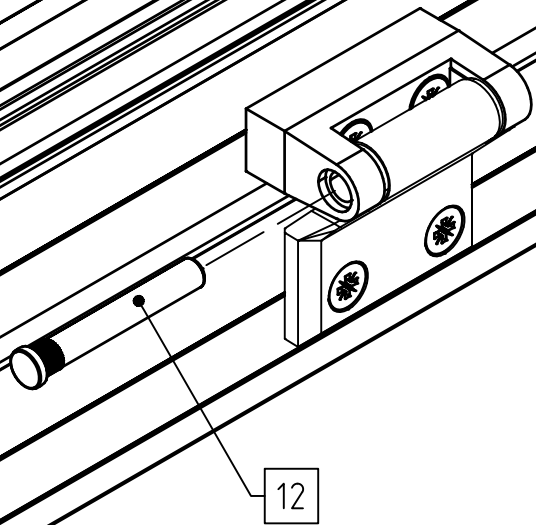

A

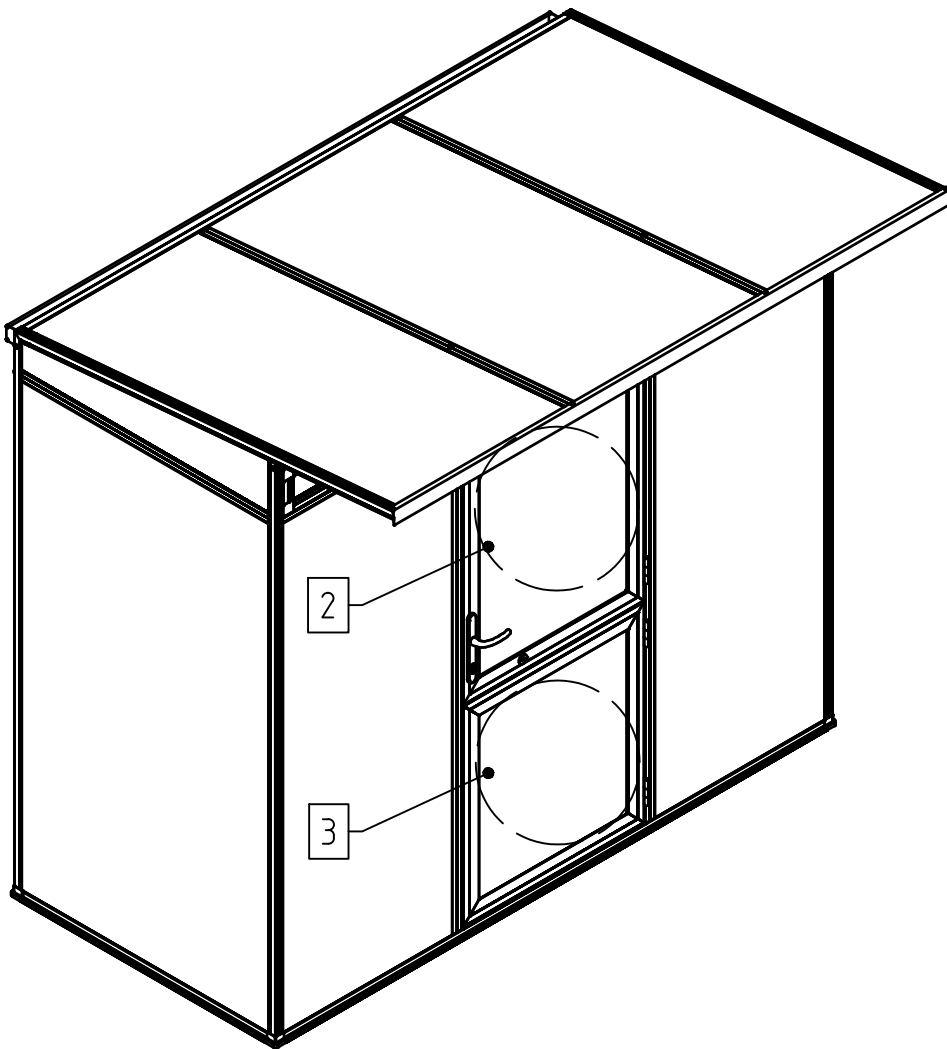

2x

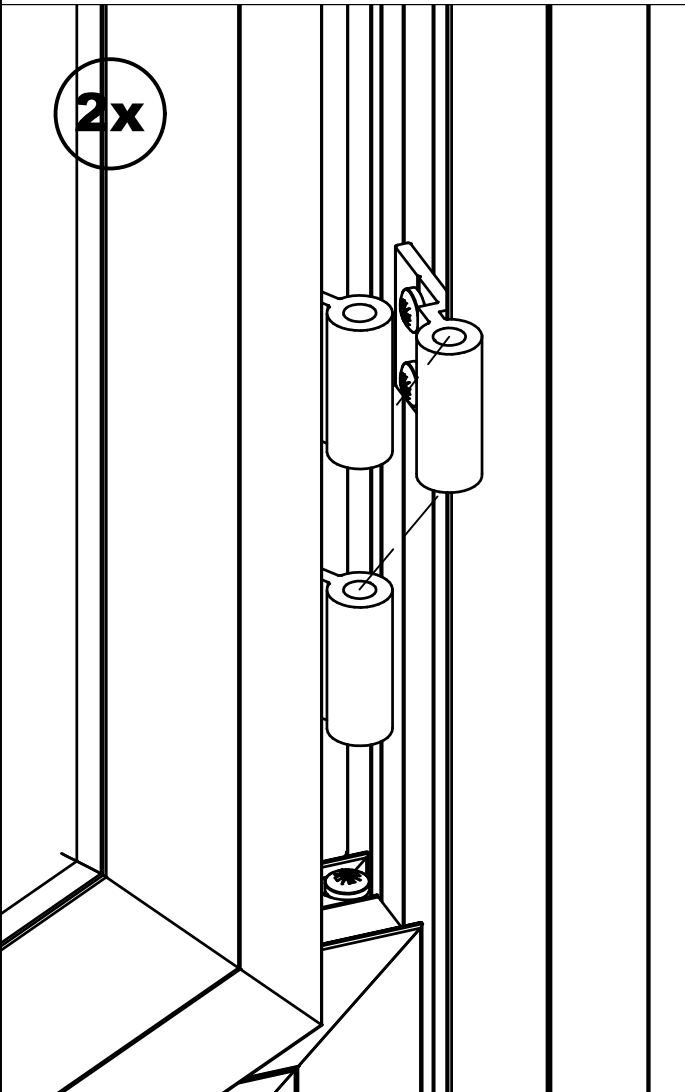

4x

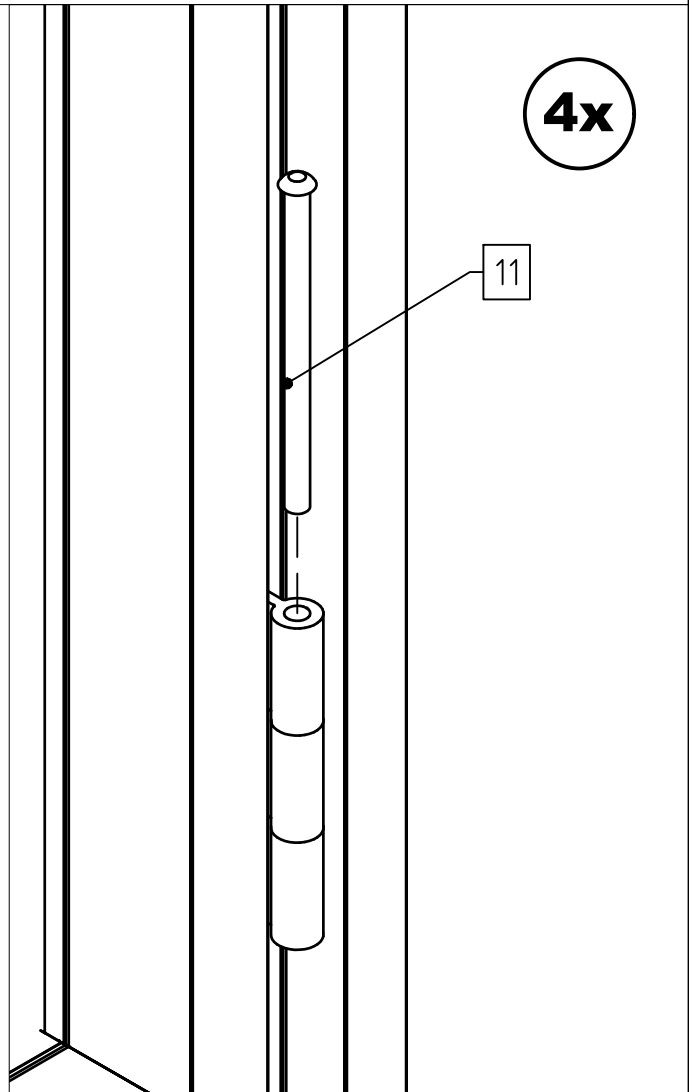

A

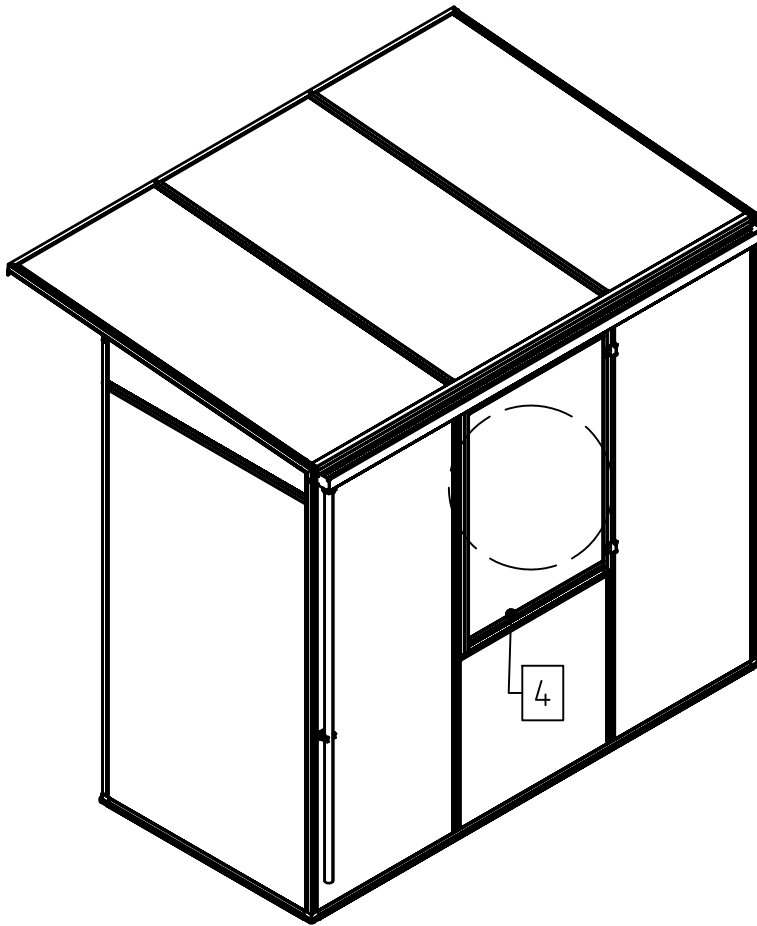

2x

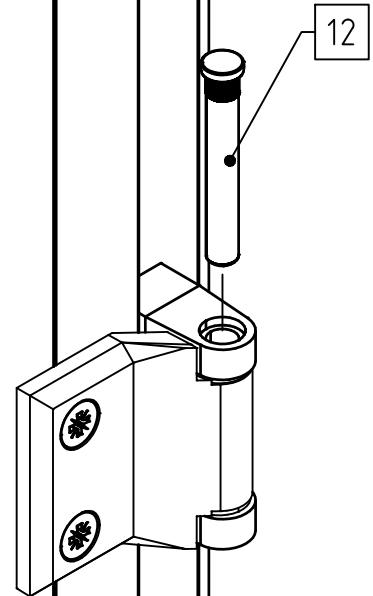
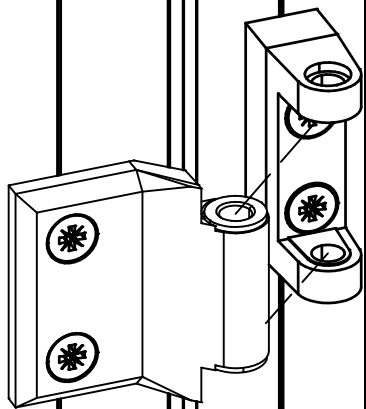

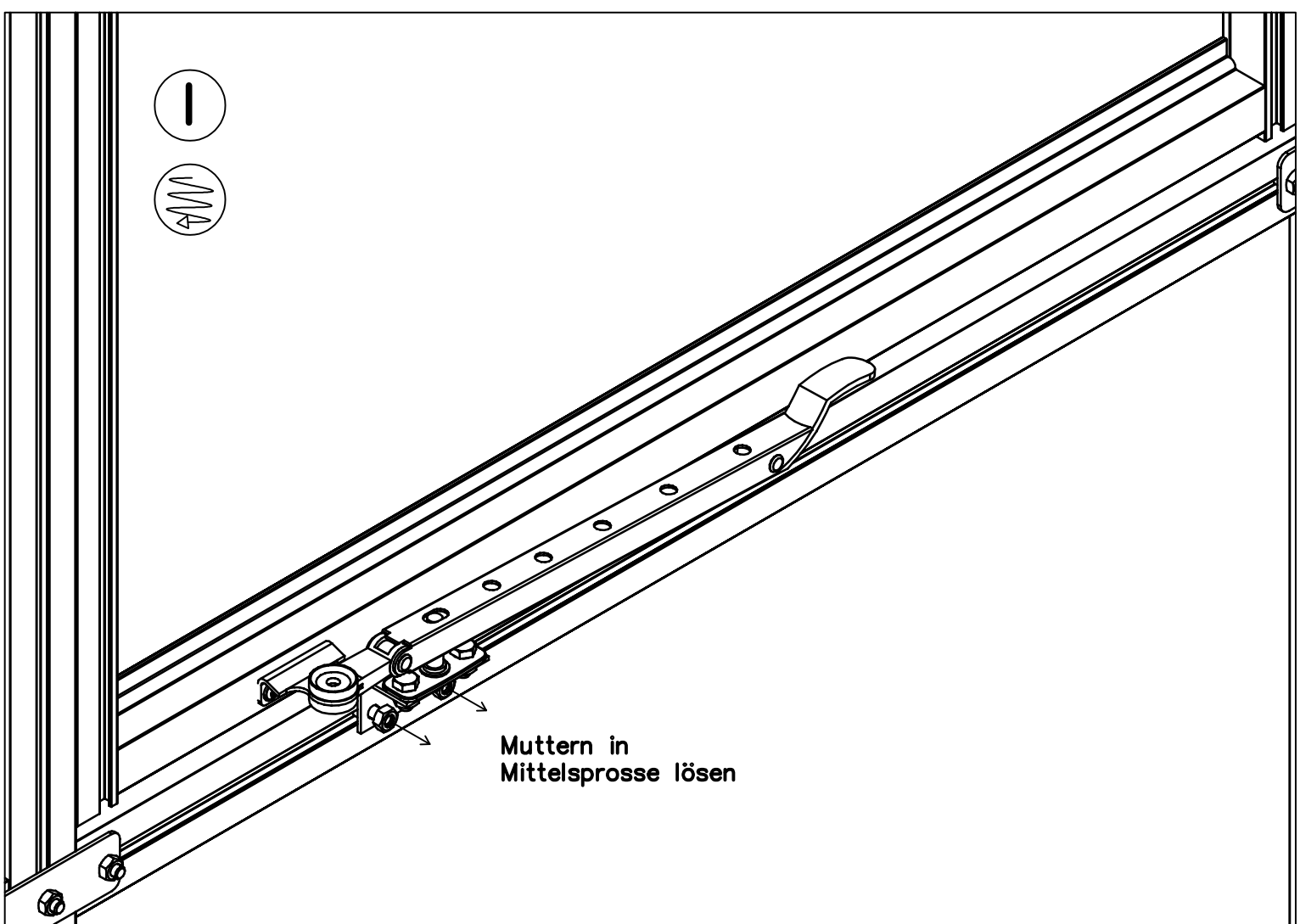

Muttern in
Mittelsprosse lösen

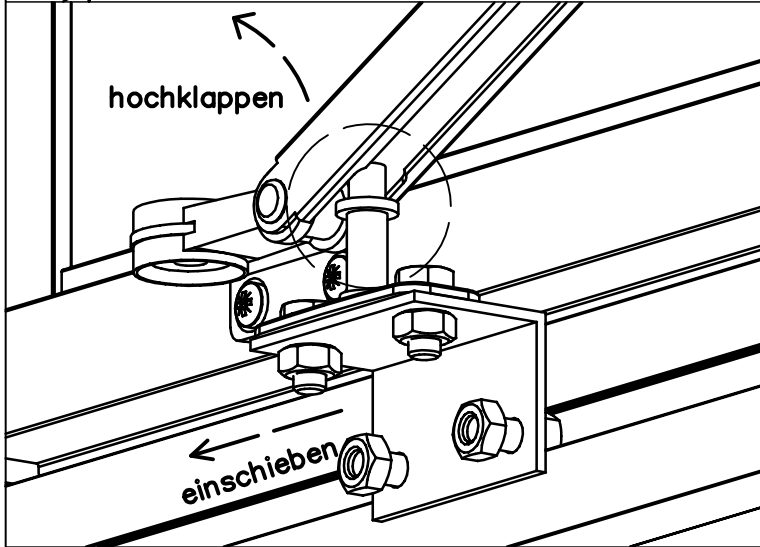

hochklappen

einschieben

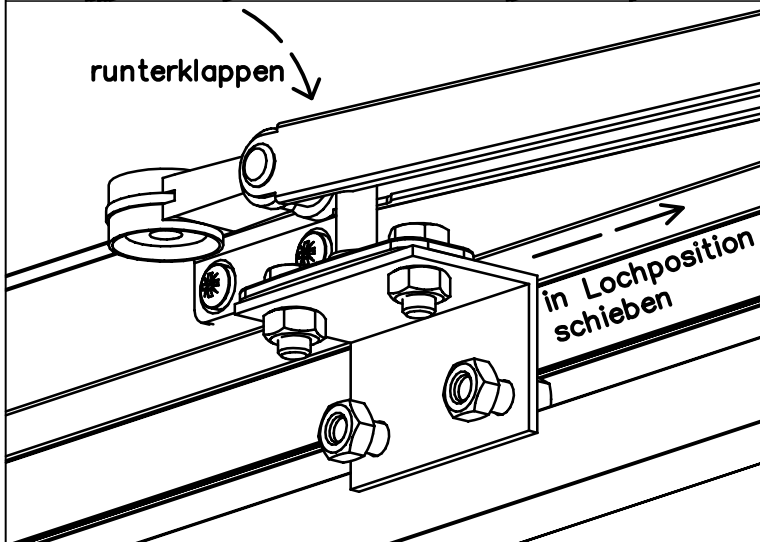



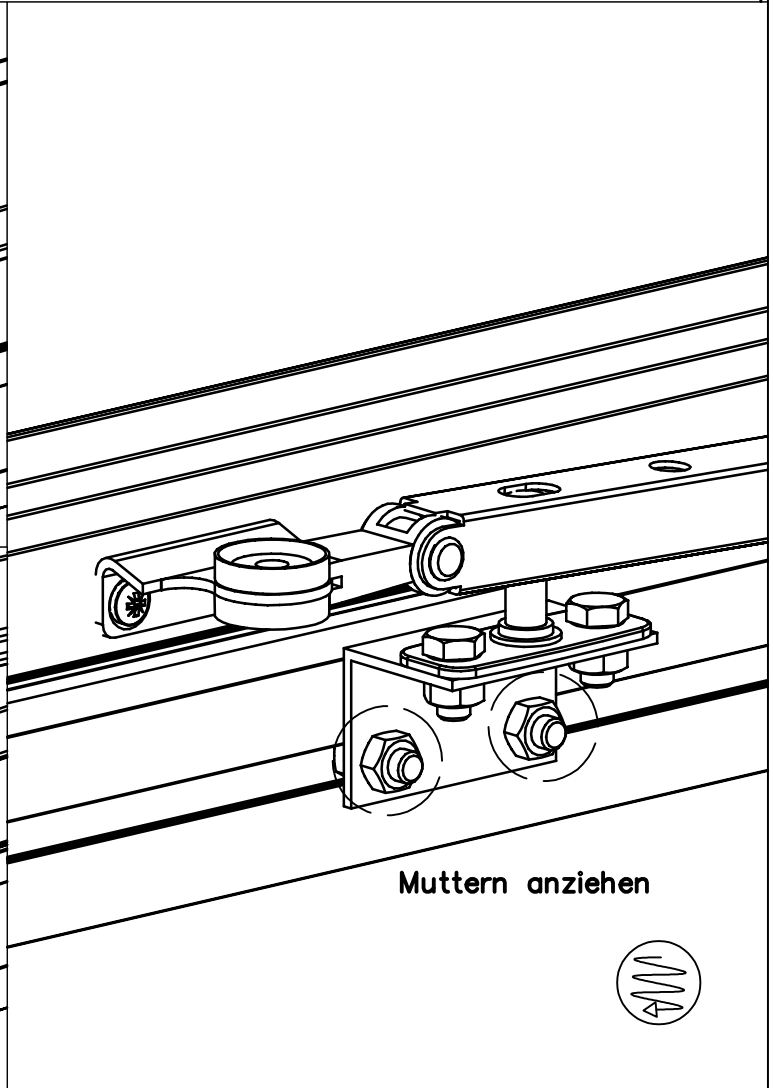

runterklappen

in Lochposition
schieben

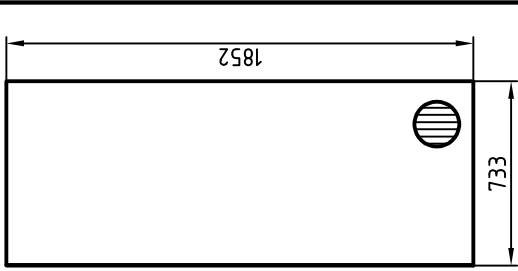
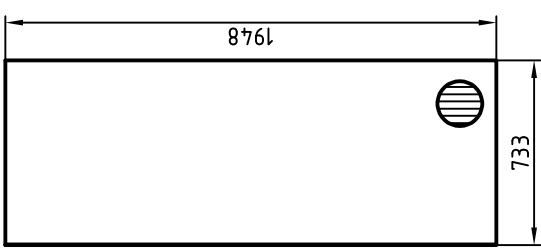
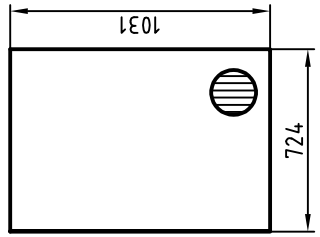

Muttern anziehen

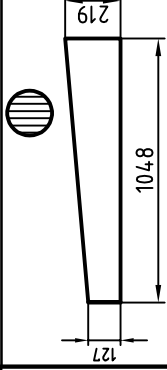
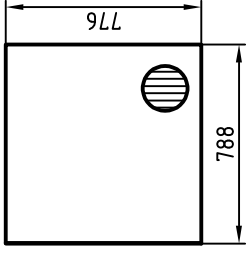
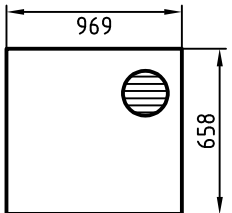
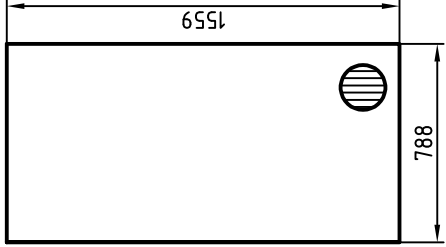
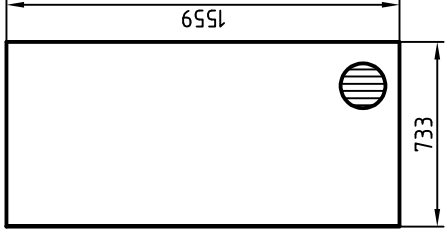
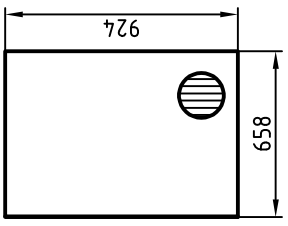
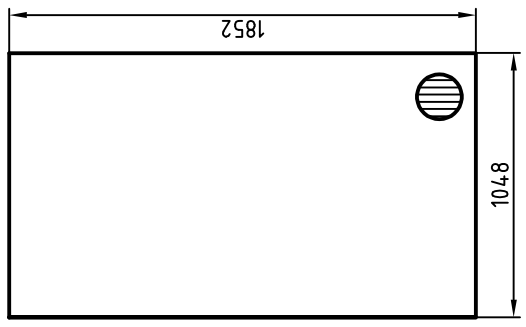
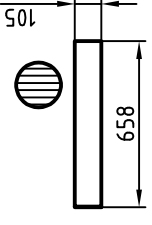

V400-27-00-00-14-1 Türgiebel links/rechts 2 Stück	V400-34-00-00-14-1 Rückwandgiebel links/rechts 2 Stück	V400-31-00-00-14-1 Rückwandfenster 1 Stück	V400-28-00-00-14-1 Türgiebel, oberhalb Tür 1 Stück	V400-41-00-00-1 Seite, oben 1x links/1x rechts	V400-32-00-00-14-1 Rückwandgiebel, unten 1 Stück
					
V400-03-00-00-14-1 geteilte Drehtür, unten 1 Stück		V400-39-00-00-14-1 Dach, Mitte 1 Stück		V400-37-00-00-14-1 Dach, links/rechts 2 Stück	
					
V400-01-00-00-14-1 geteilte Drehtür, oben 1 Stück		V400-36-00-00-14-1 Seite 2 Stück		V400-29-00-00-14-1 Oberlicht 2 Stück	
					
kg/m		Beschichtung		Material:	
0,00 kg		0,00 m ²		1:30	
kg/gesamt		0,00 kg		PC-HKP 10 mm	
Datum		Name		W310-00-00-00-14-1	
17/04/25		Hedemann		Lineal	
Komm.				Blatt:	
				1	
				1 Bl.	
				 Kreative-Garten-Technik	

 = Stegverlauf

Versiegelung Gewächshaus:
Übergänge zwischen Hohlkammerplatten und Profilen im Dachbereich mit dem beiliegendem Silikon versiegeln.

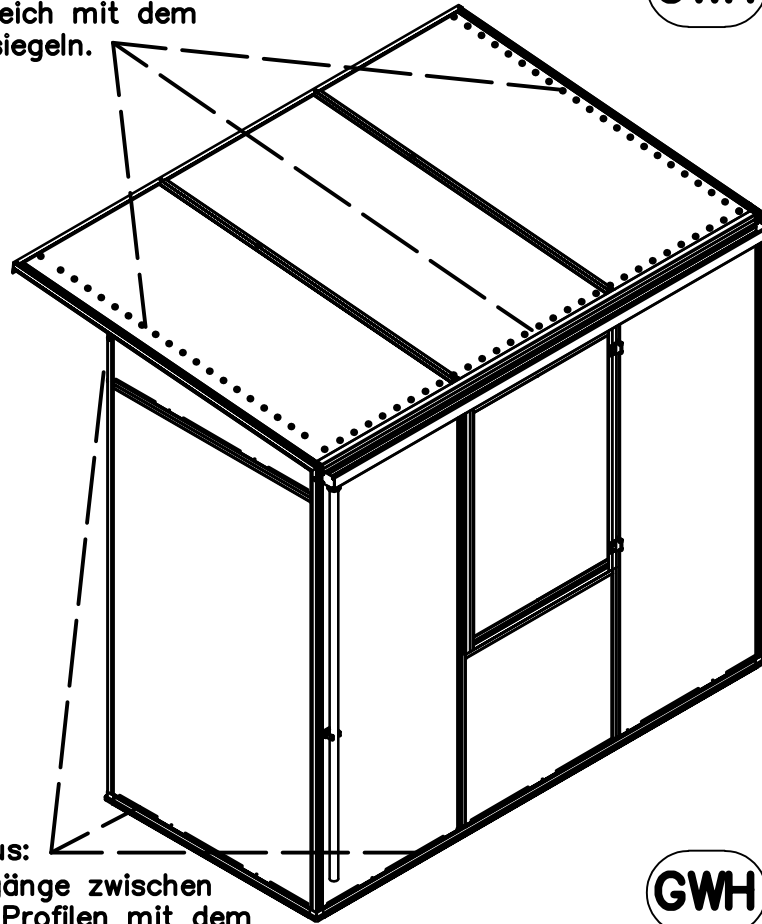
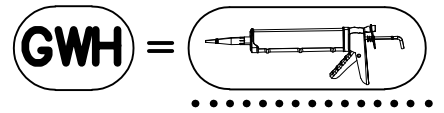

Versiegelung Gewächshaus:
Alle waagerechten Übergänge zwischen Hohlkammerplatten und Profilen mit dem beiliegendem Silikon versiegeln.

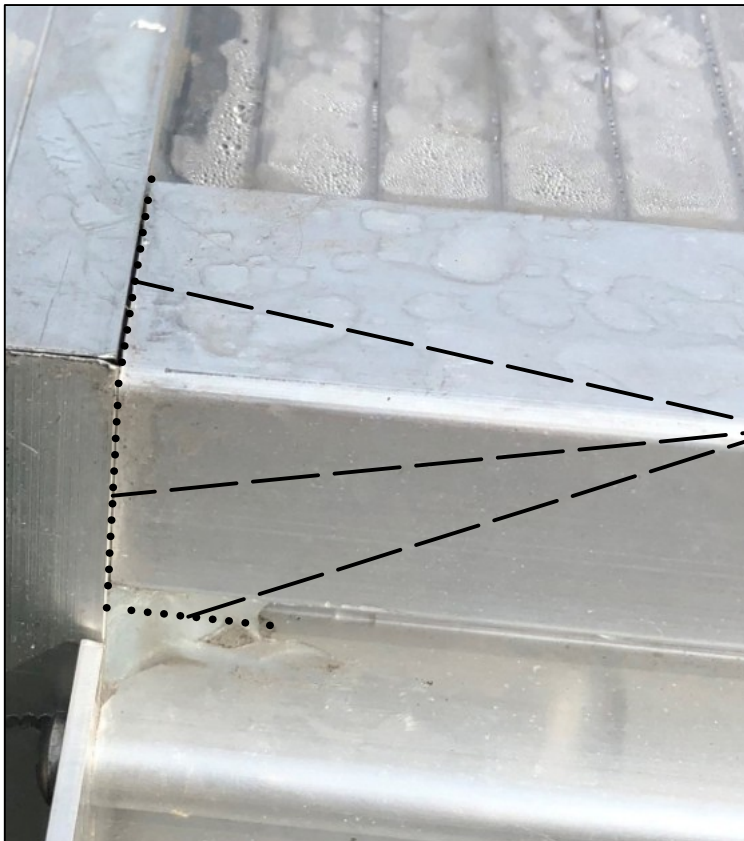
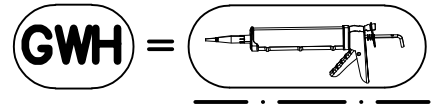

Versiegelung Gewächshaus:
Übergänge zwischen den Profilen mit dem beiliegendem Silikon versiegeln.

Installation instructions:

P = page XX

- P 30 Observe the position of the glass block! Bottom right!
- P 32 Observe the position of the glass block! Top left!
- P 44 No drillhole! Needs to be drilled on site!
- P 47 Observe the position of the glass block! Bottom right!
- P 49 Observe the position of the glass block! Top left!
- P 63 Bottom view!
- P 73 Inner measurement 758 mm
- P 78 Slide on!
- P 103 Watch slope!
- P 134 Loosen nut / lift the lever / push in / turn down lever / push in holeposition / tighten nut
- P 135 Seal connections between profiles and hollow chamber plates.

Instructions d'installation:

P = page XX

- P 30 Observez la position du bloc de verre ! En bas à droite !
- P 32 Observez la position du bloc de verre ! En haut à gauche !
- P 44 Pas de trou de forage ! Doit être foré sur place !
- P 47 Observez la position du bloc de verre ! En bas à droite !
- P 49 Observez la position du bloc de verre ! En haut à gauche !
- P 63 Vue du bas !
- P 73 Mesure intérieure 758 mm
- P 78 Faites glisser !
- P 103 Pente de surveillance !
- P 134 Desserrer l'écrou / soulever le levier / pousser vers l'intérieur / tourner le levier vers le bas / pousser vers l'intérieur Position du trou / serrer l'écrou
- P 135 Sceller les connexions entre les profilés et les plaques de chambre creuse.

Installatie-instructies:

B = bladzijde XX

- B 30 Let op de positie van het glasblok! Rechtsonder!
- B 32 Let op de positie van het glasblok! Linksboven!
- B 44 Geen boorgat! Moet ter plaatse worden geboord!
- B 47 Let op de positie van het glasblok! Rechtsonder!
- B 49 Let op de positie van het glasblok! Linksboven!
- B 63 Onderaanzicht!
- B 73 Binnenmaat 758 mm
- B 78 Schuif aan!
- B 103 Let op helling!
- B 134 Draai de moer los / hef de hendel op / druk de hendel in / draai de hendel omlaag / in gatpositie duwen / moer vastdraaien
- B 135 Verbindingen tussen profielen en holle kamerplaten afdichten.