

Alphol

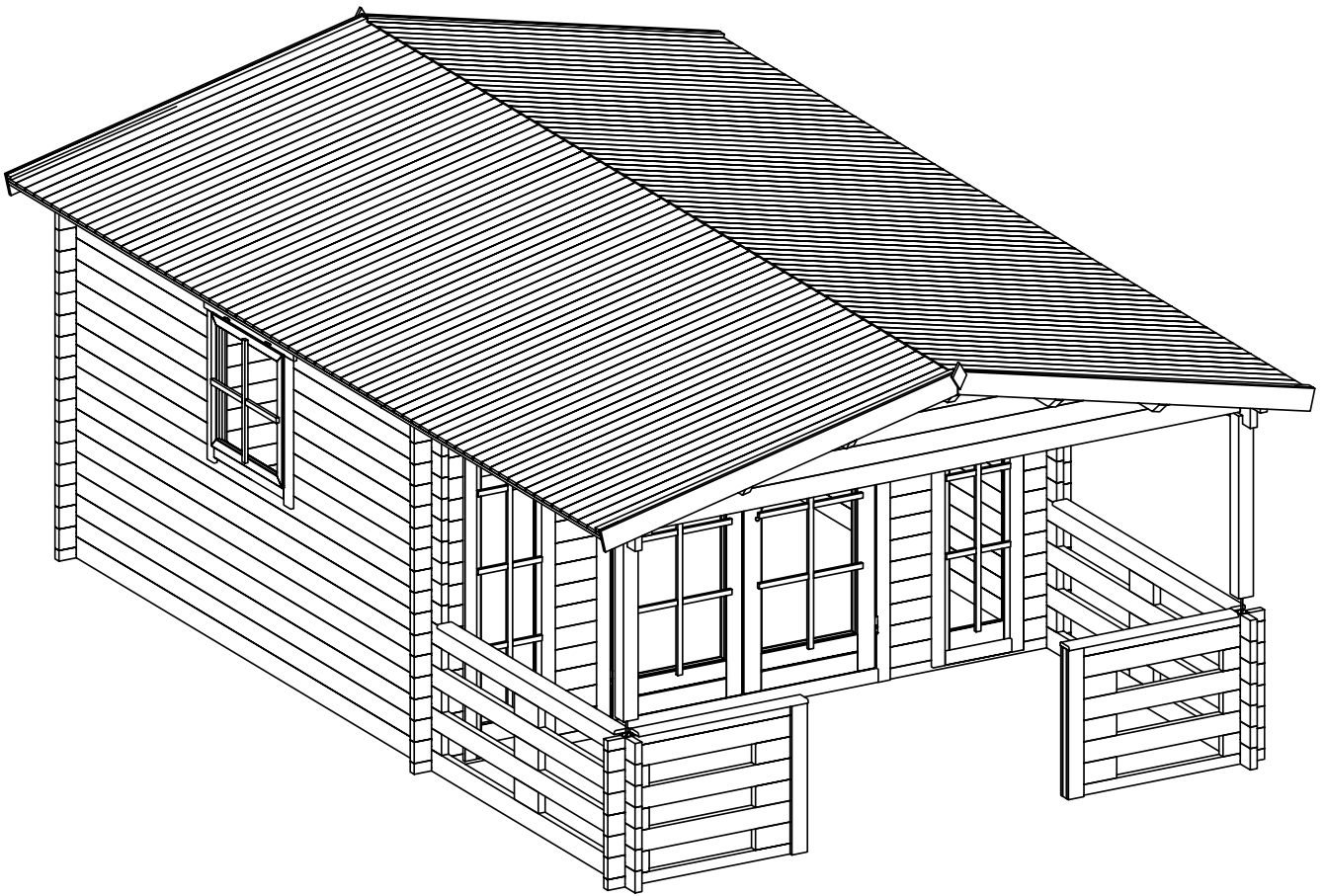

Lappland 40 A

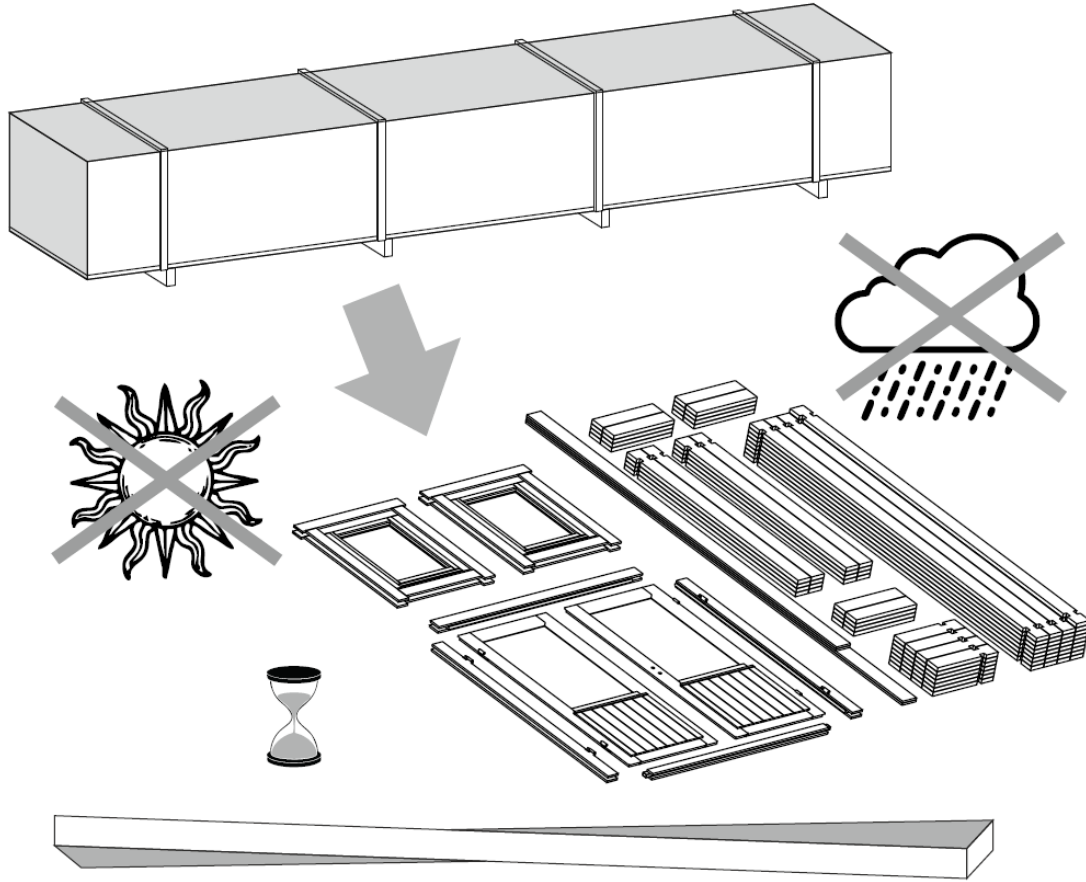

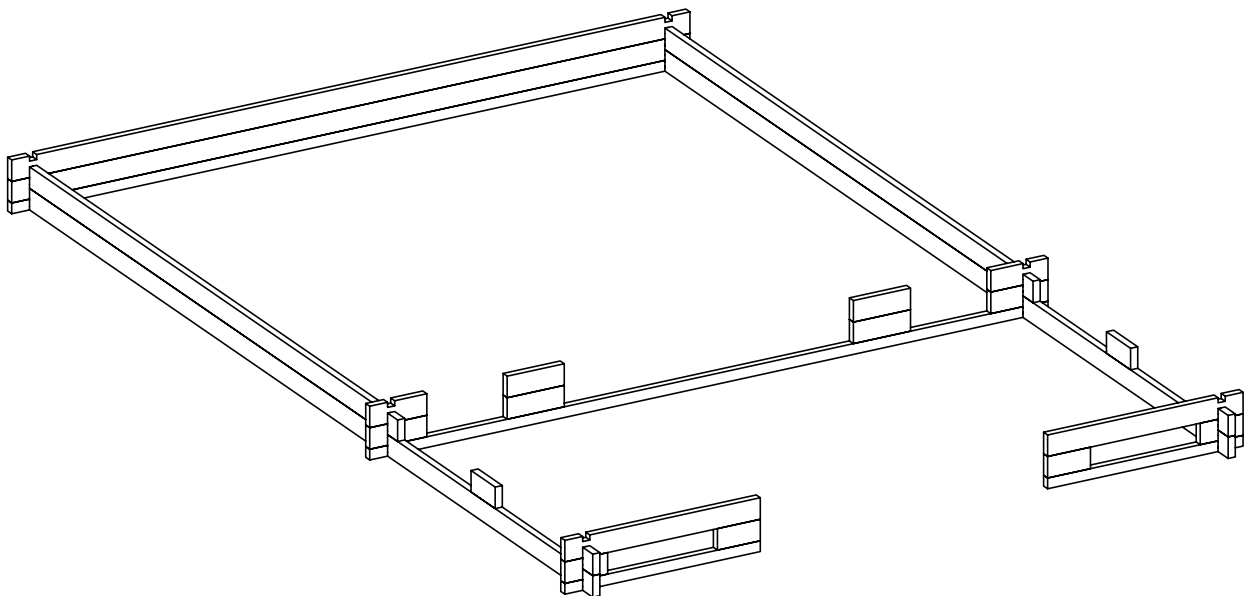
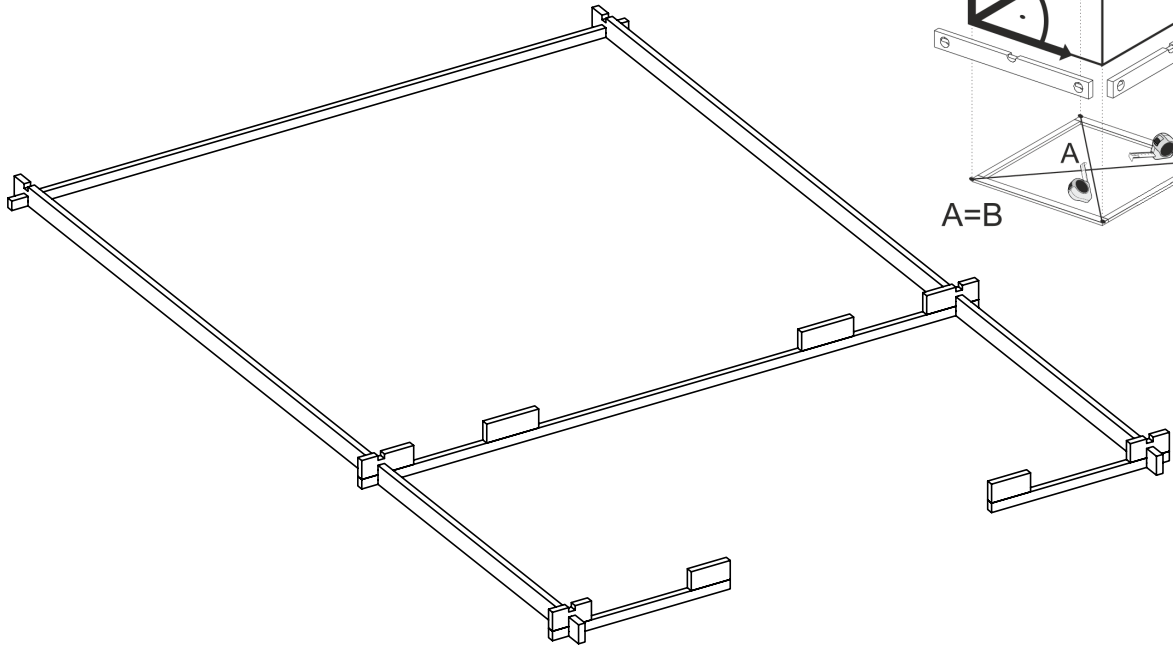
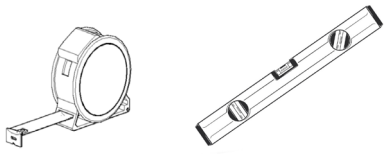

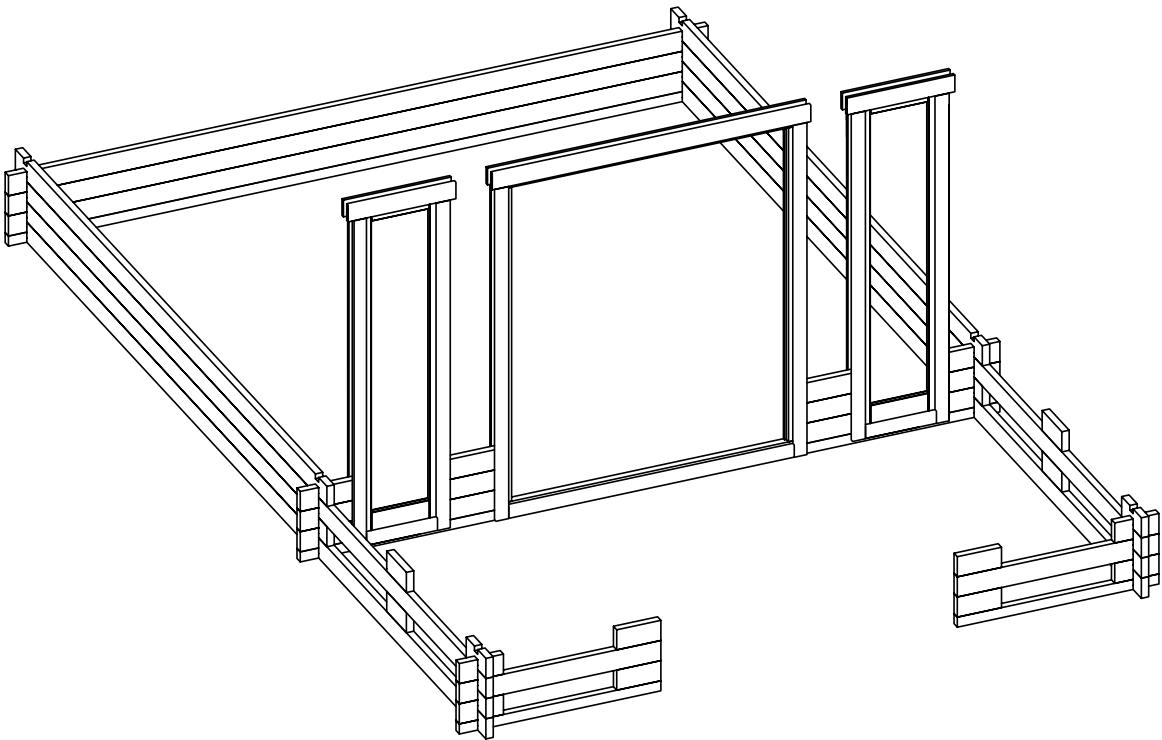
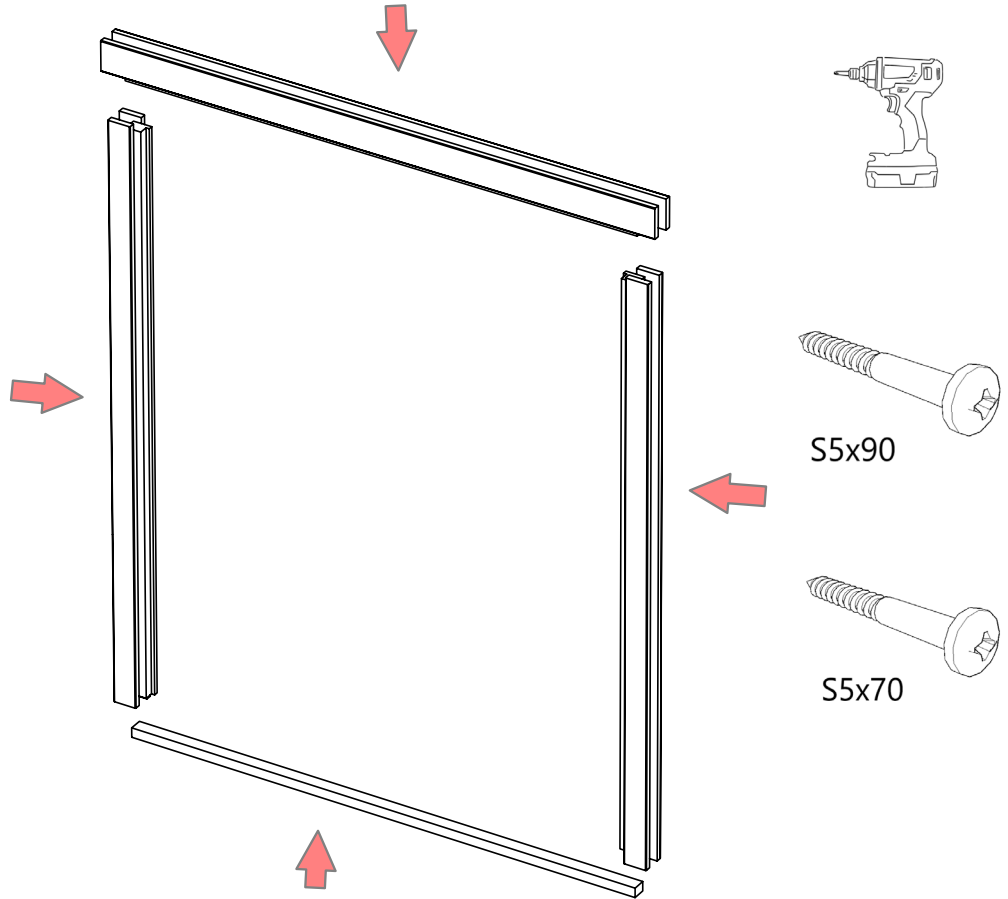

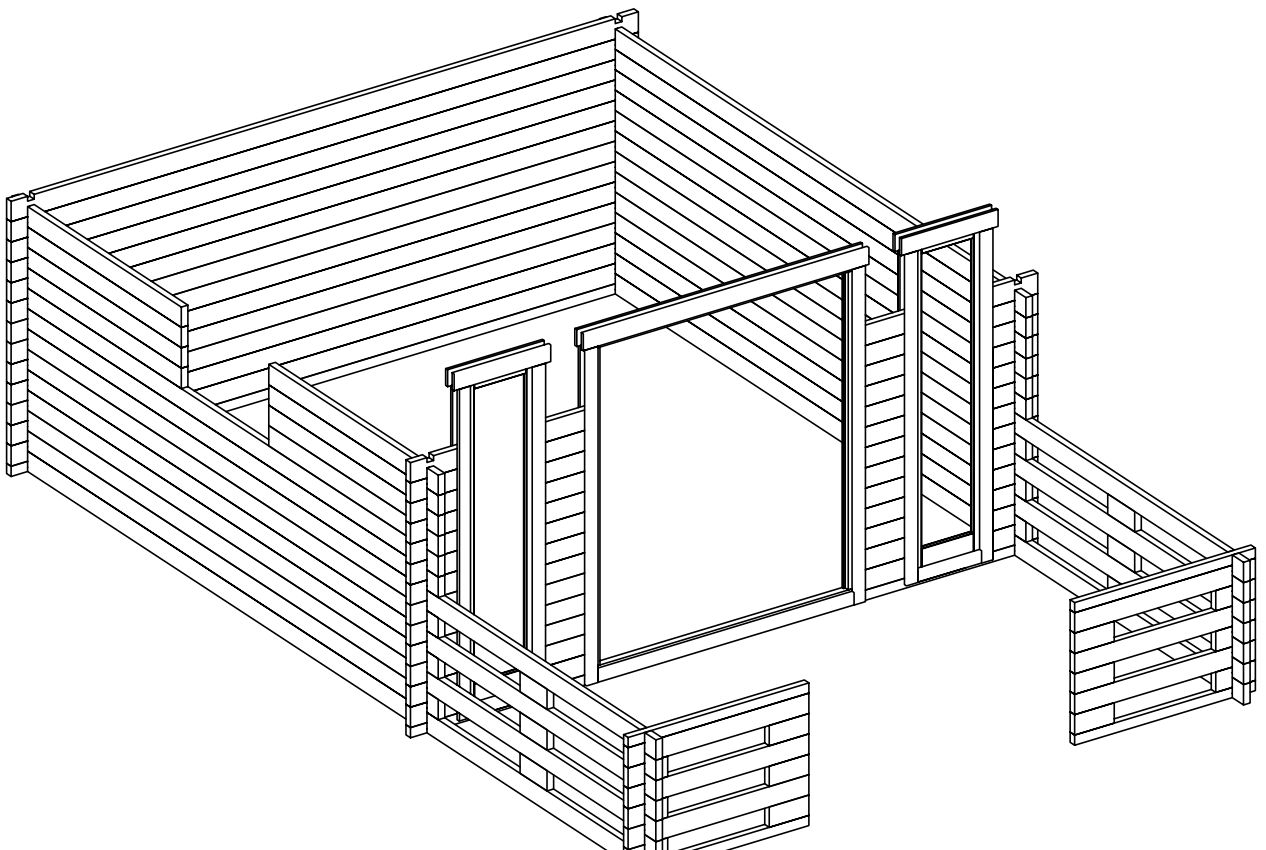
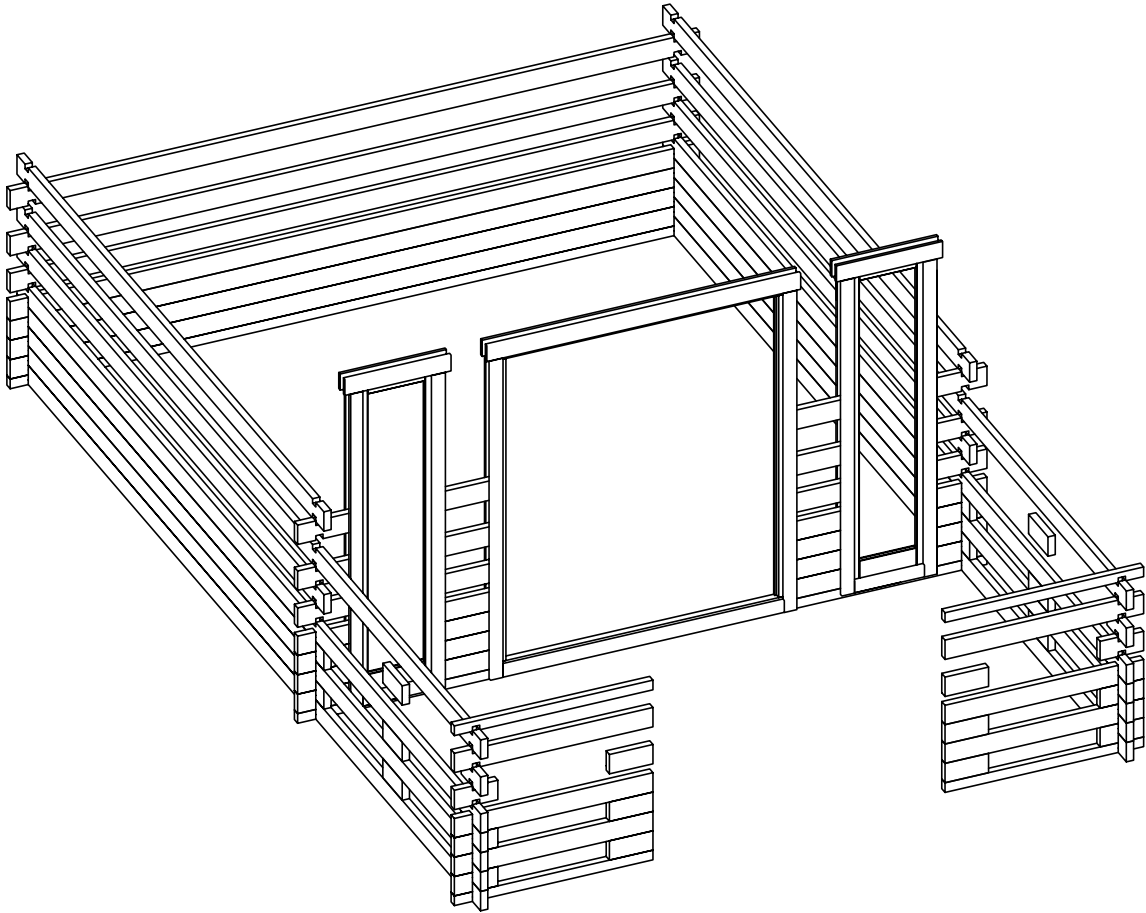

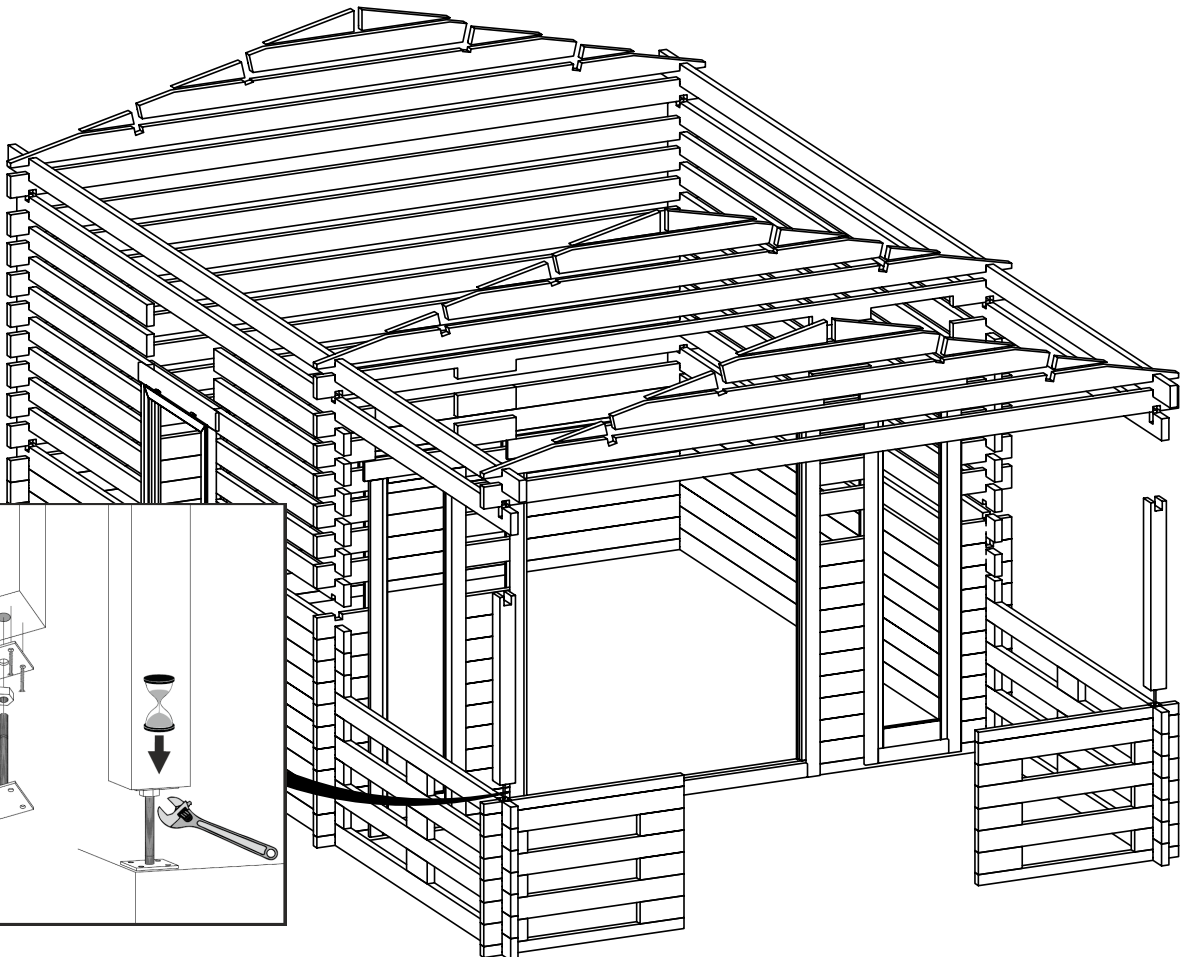
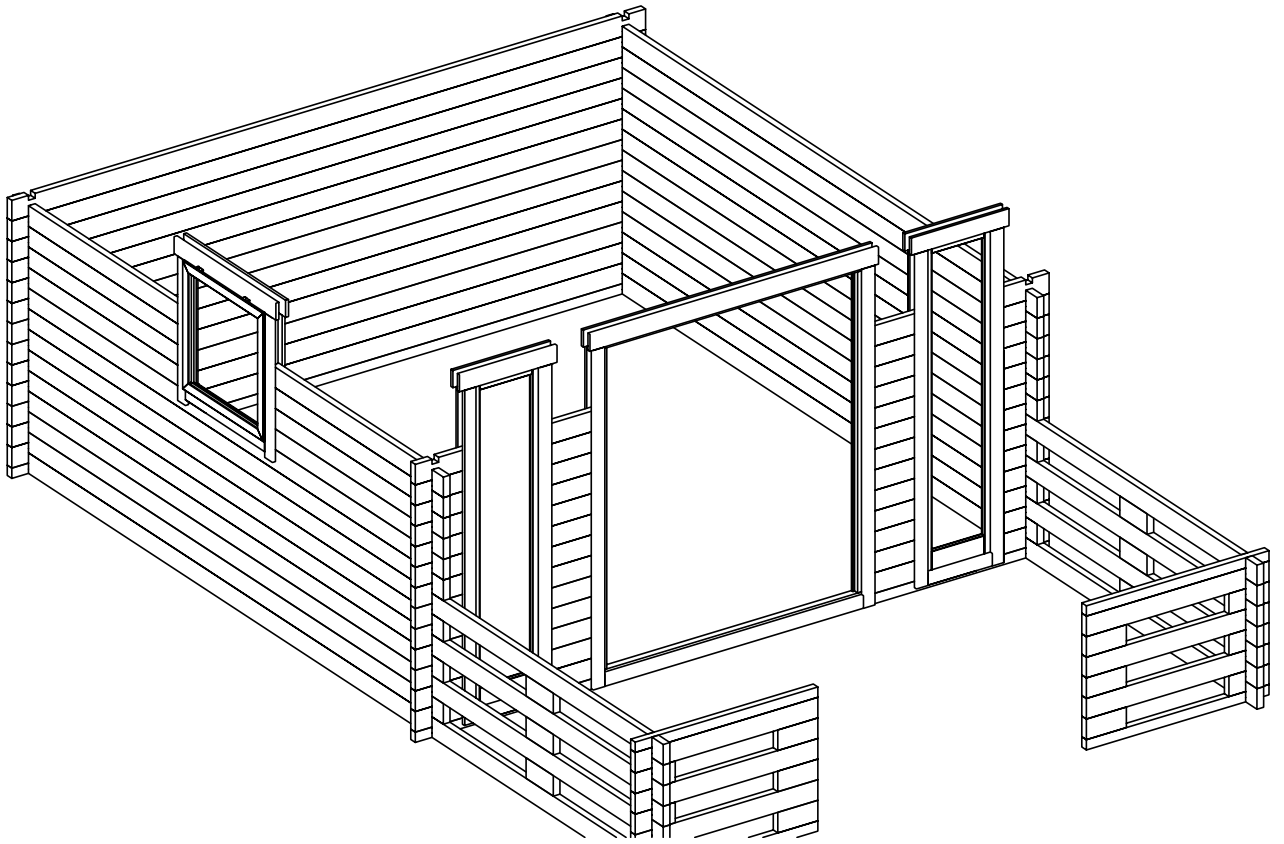

POST

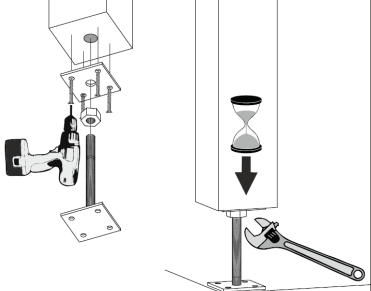

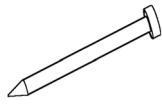
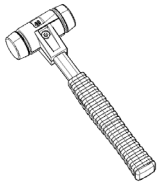
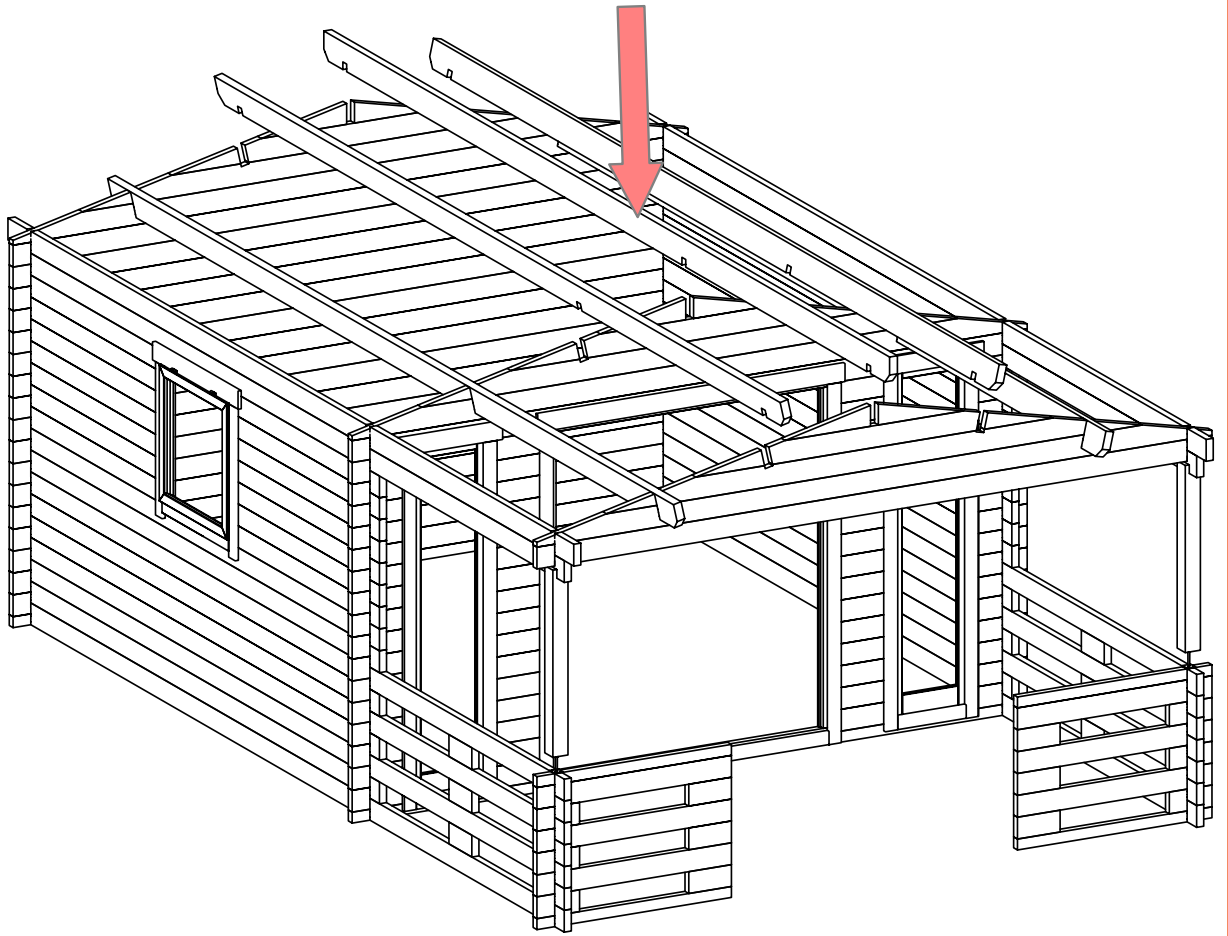

N1,8x40

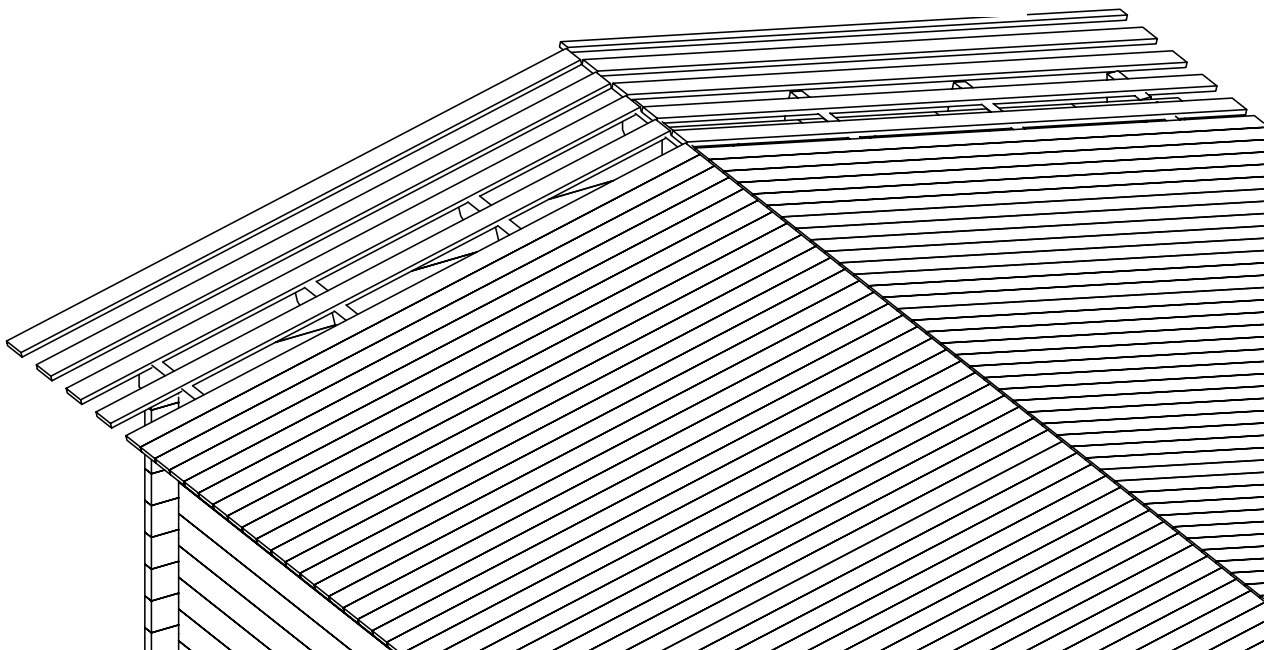
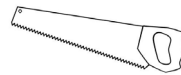
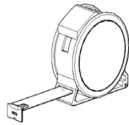

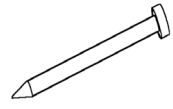
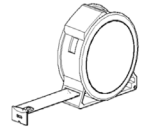
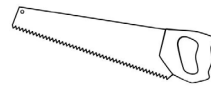

N1,8x40

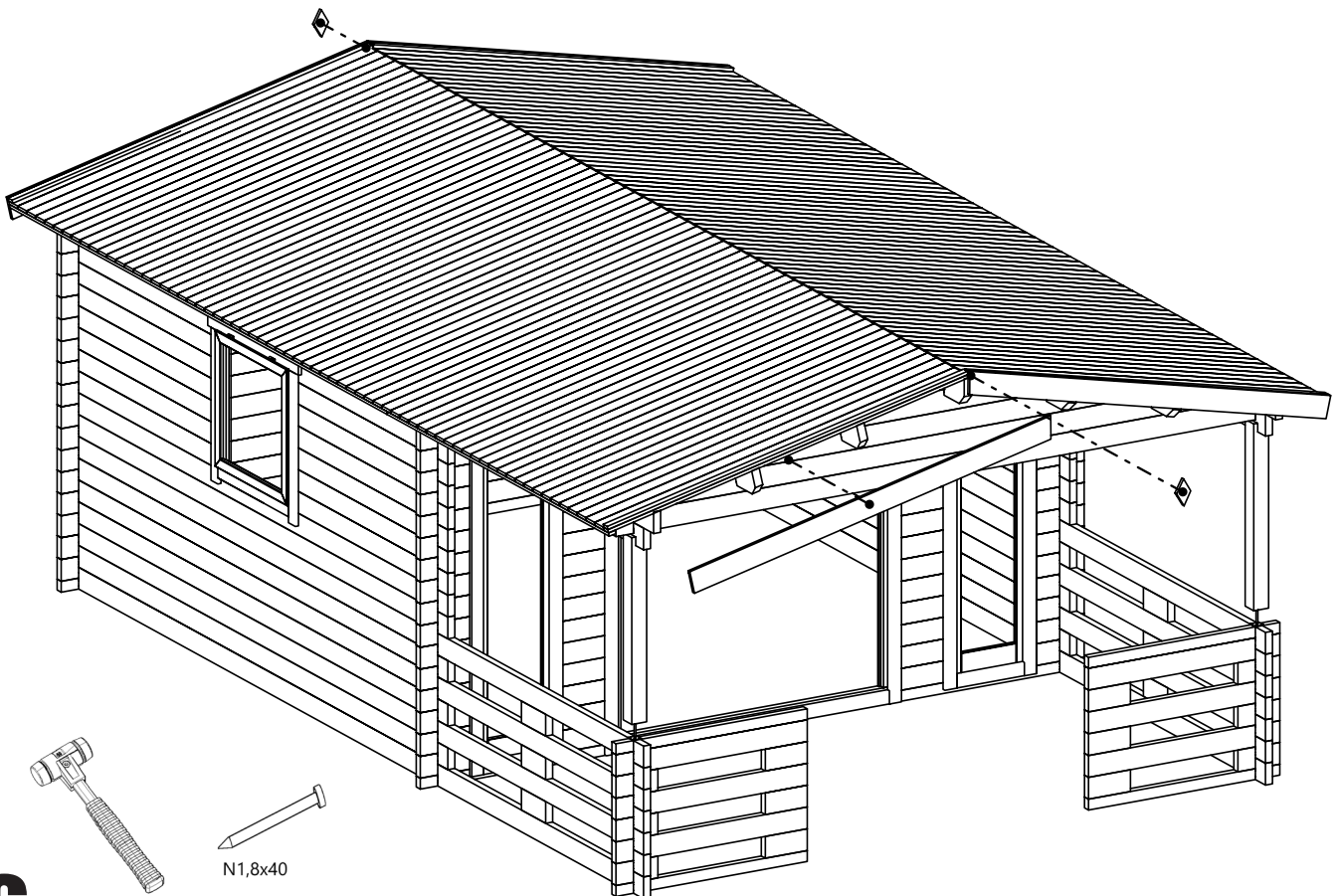
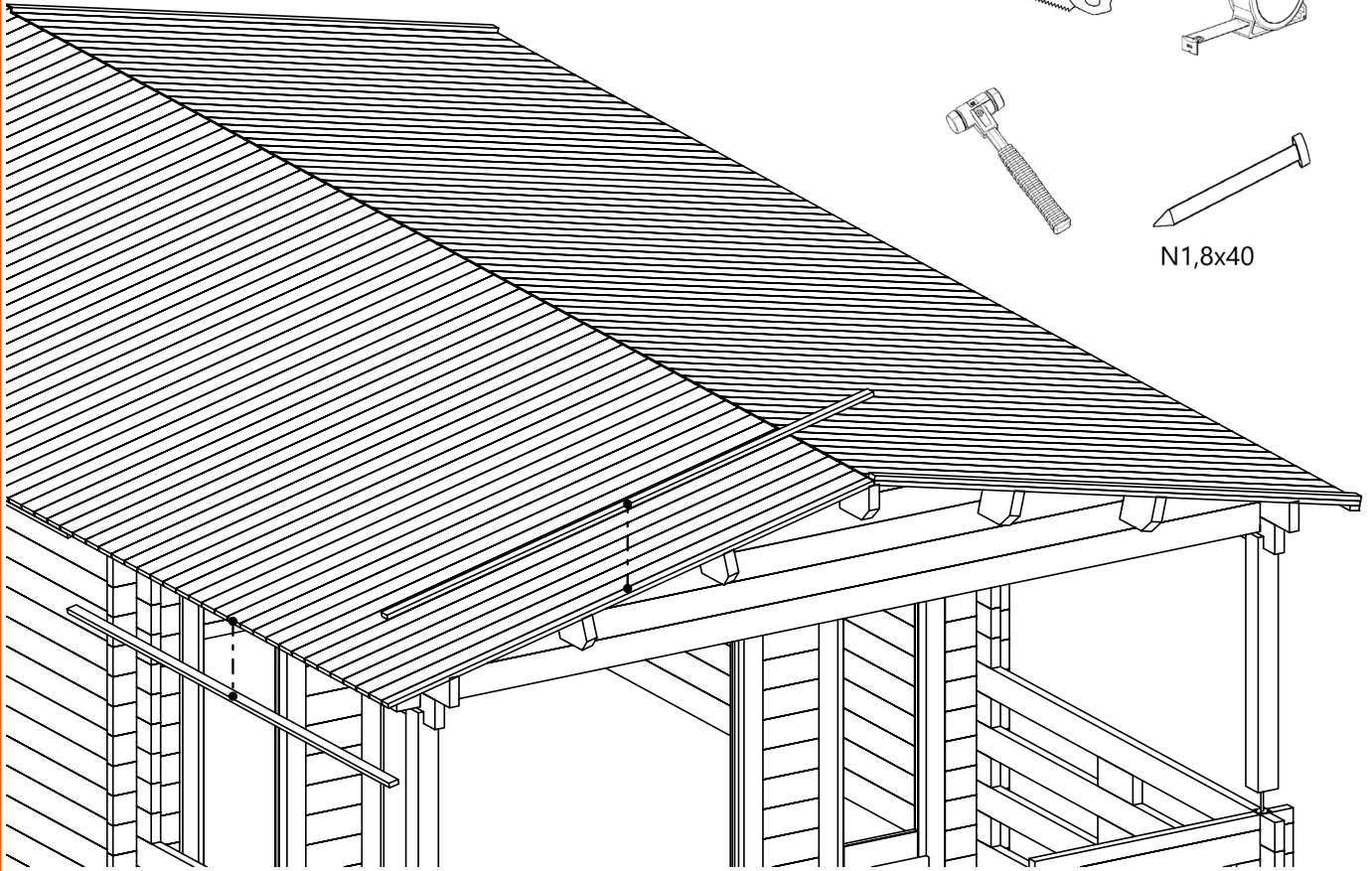

N1,8x40

6



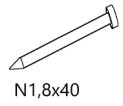

N1,8x40

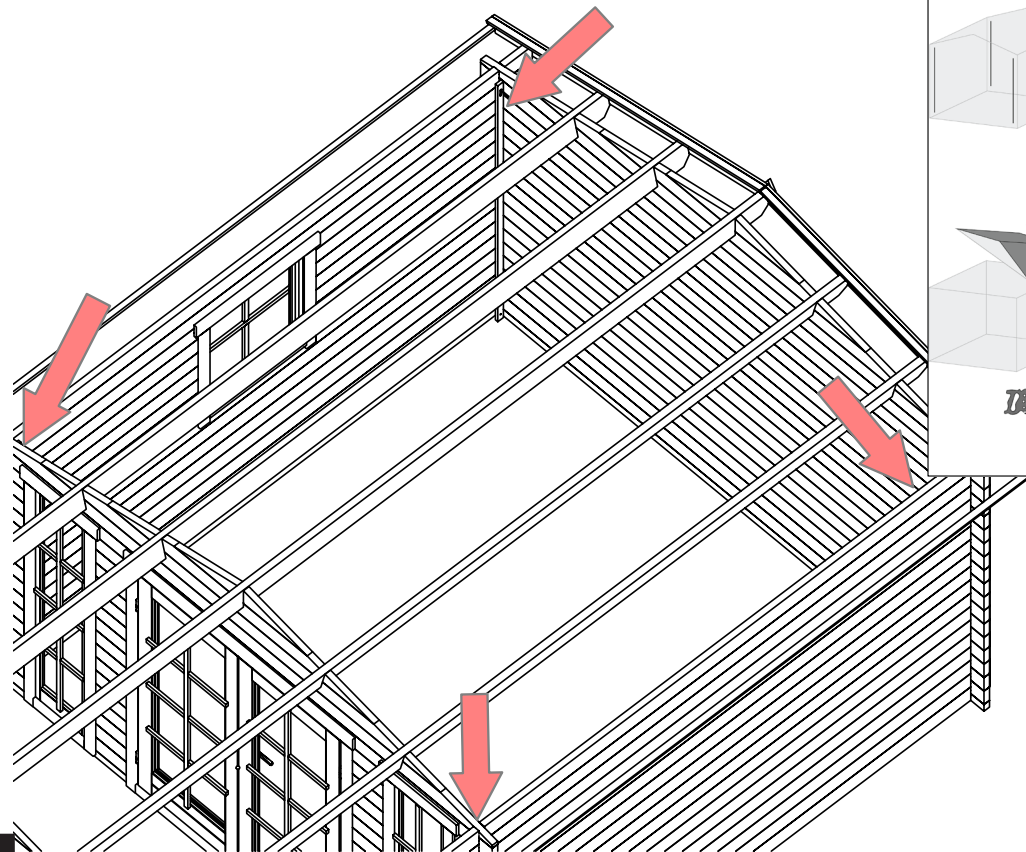
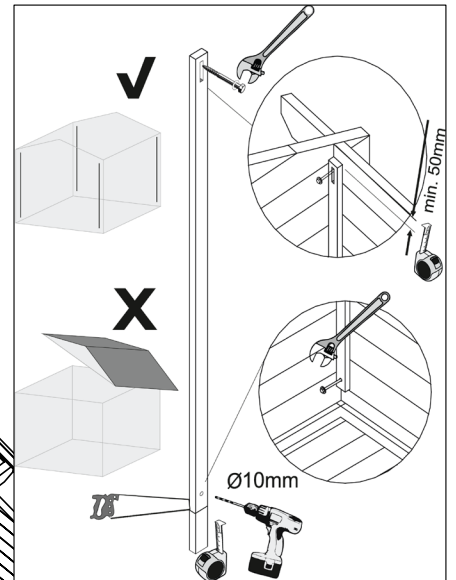
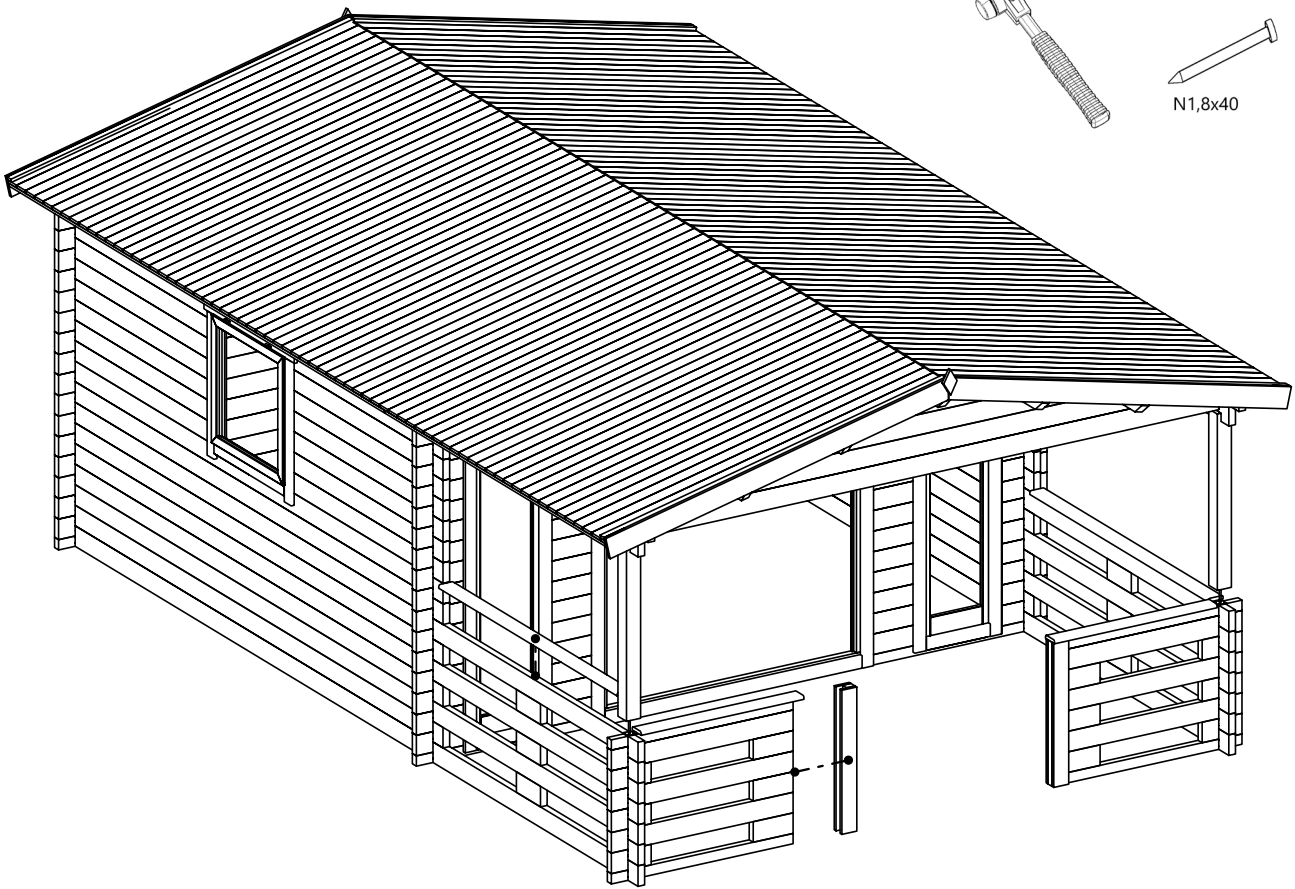

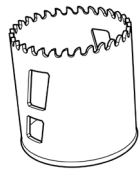
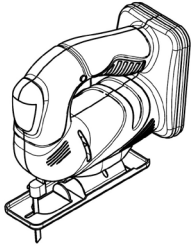



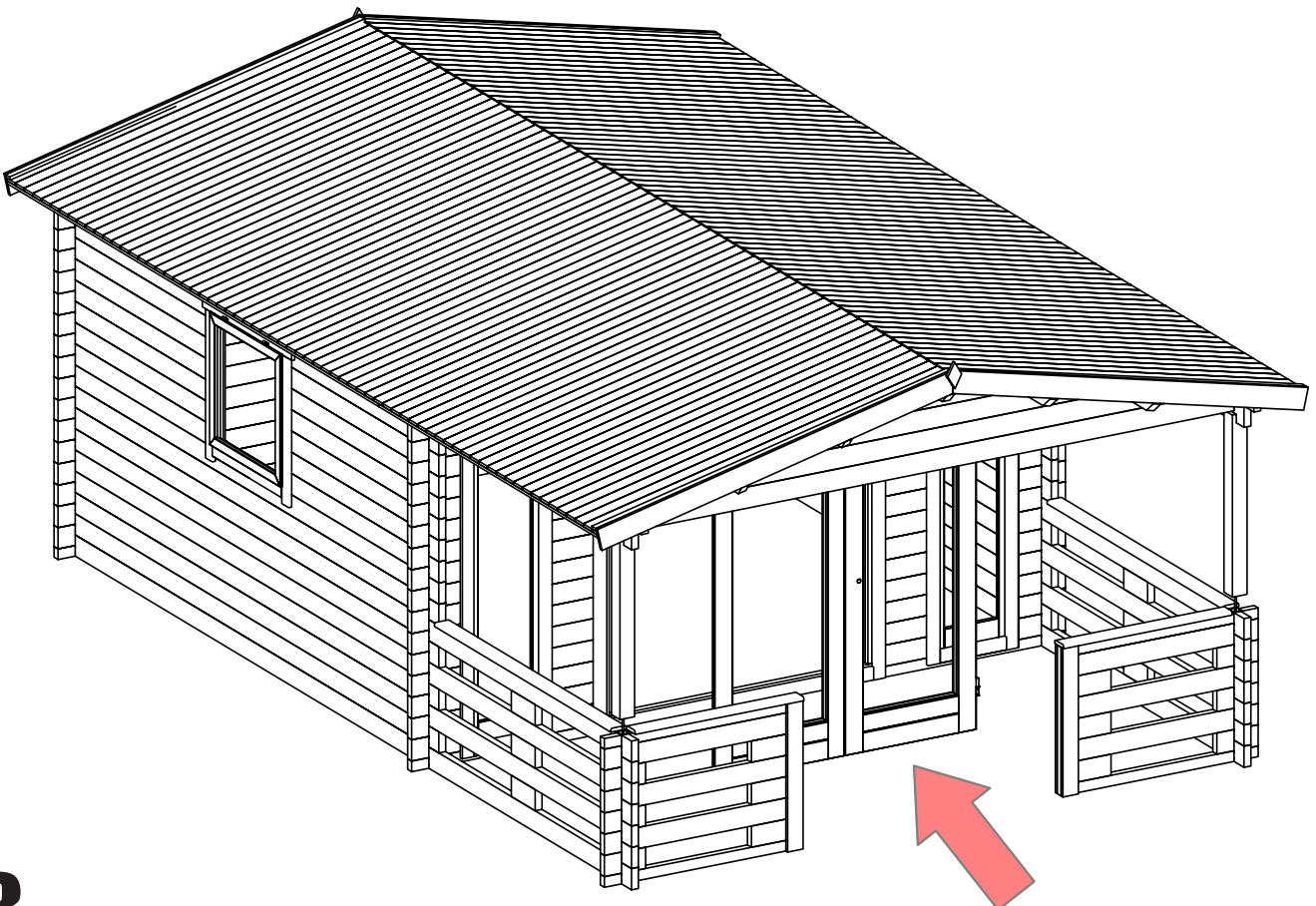
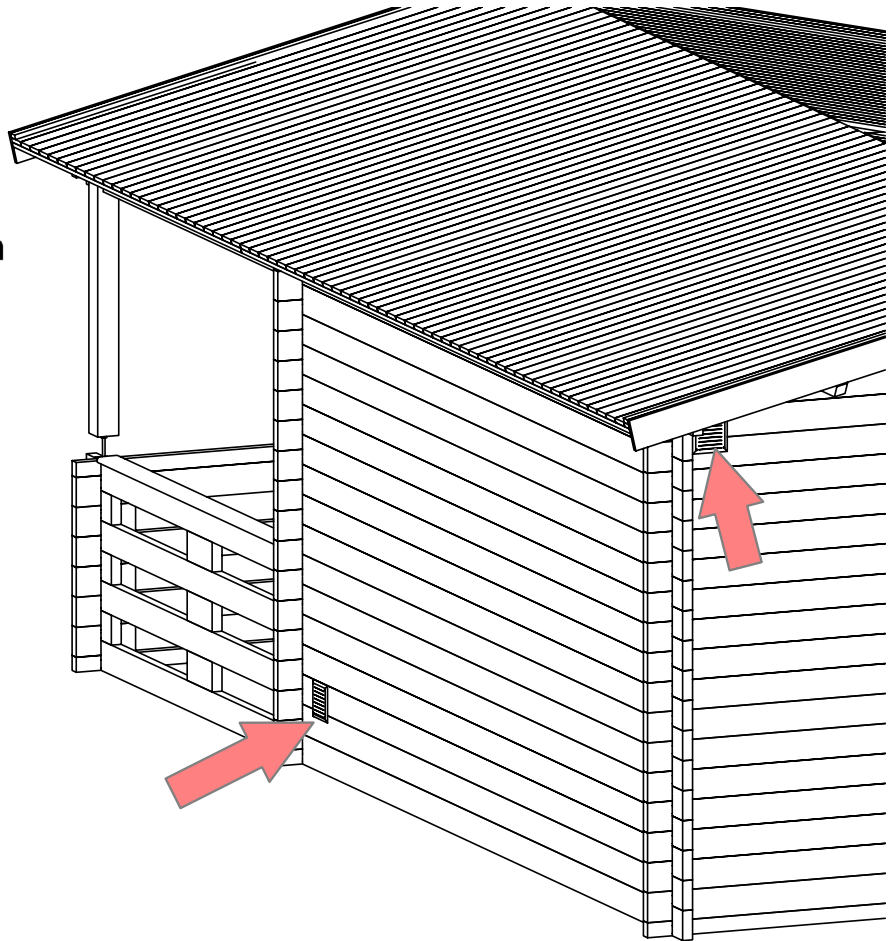
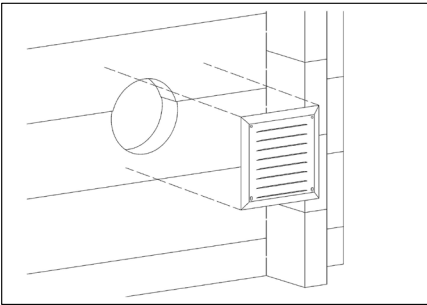
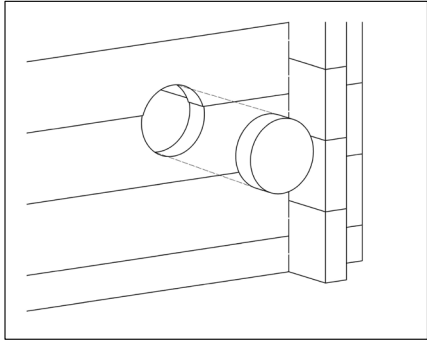

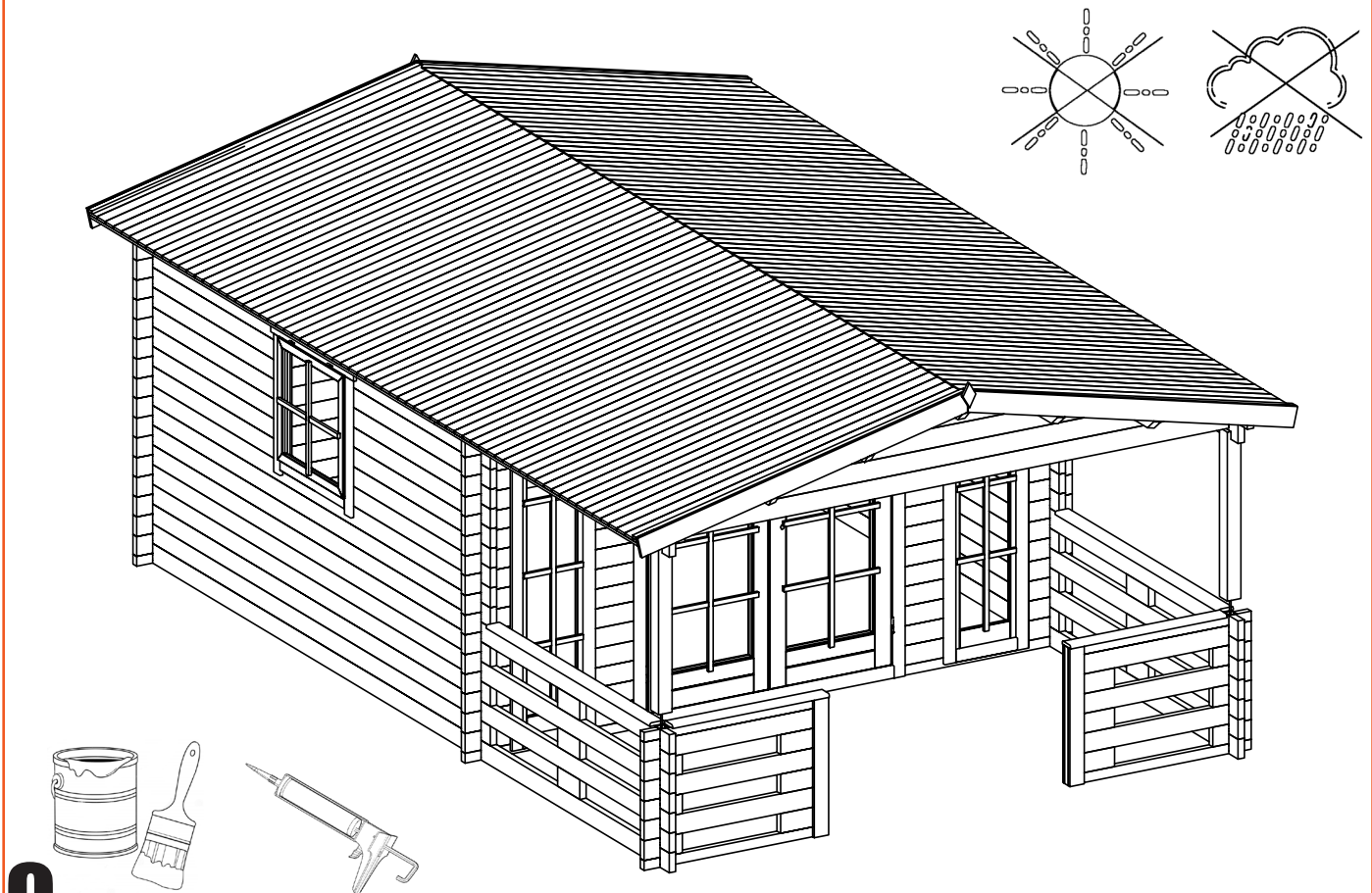
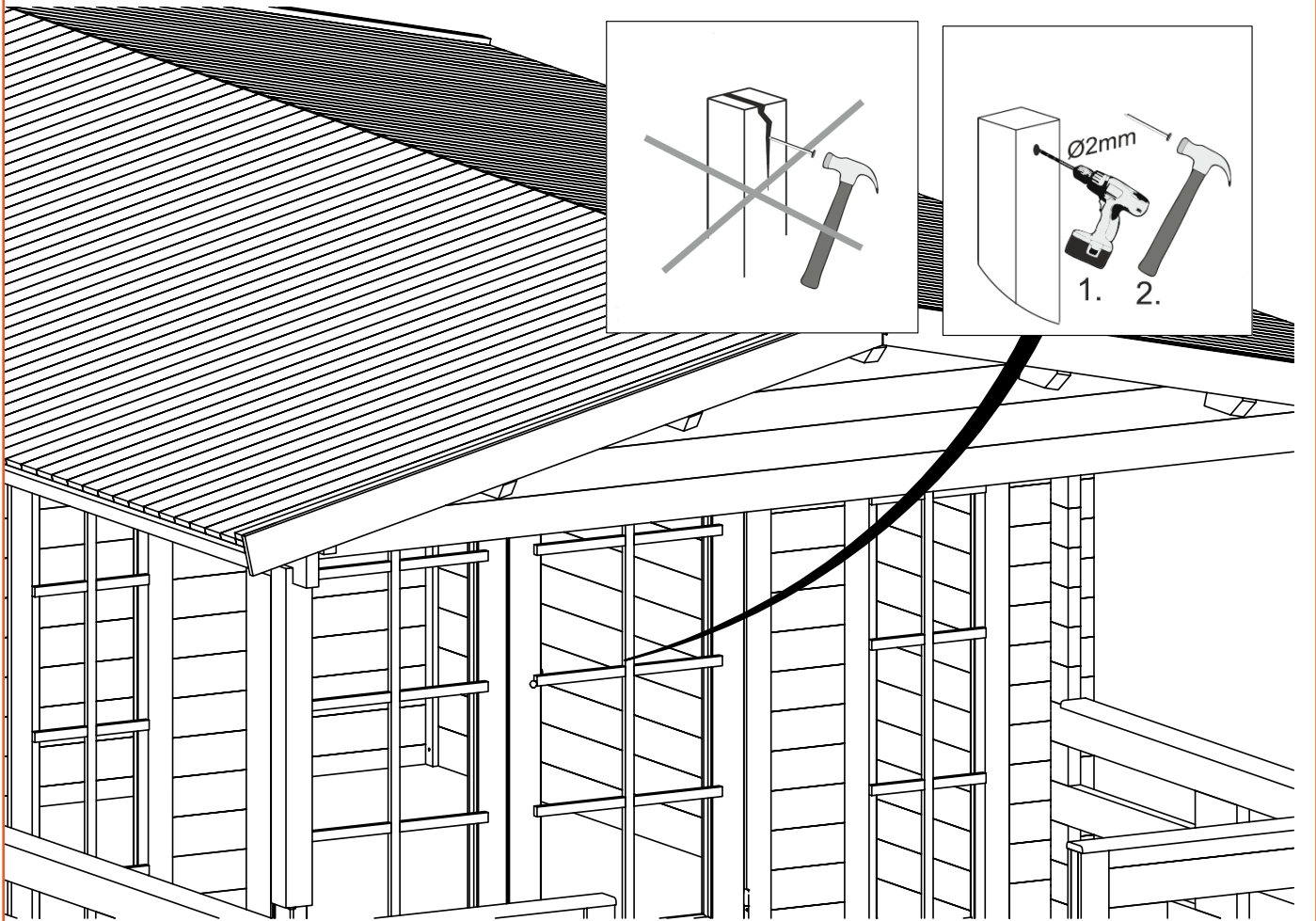
Ø ca 130mm



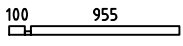

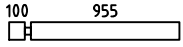
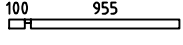
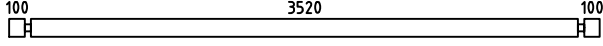
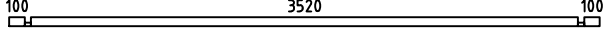

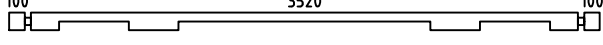
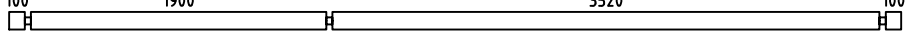
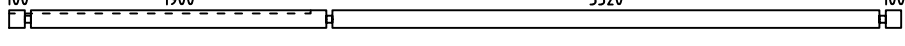
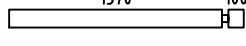
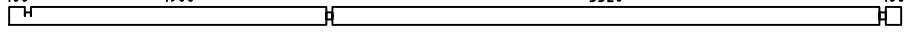
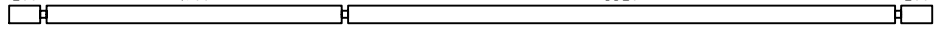
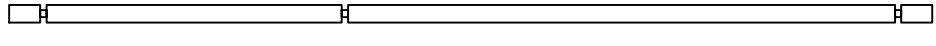
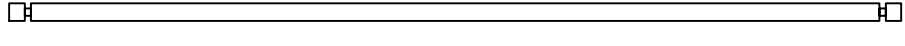
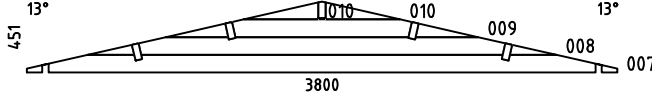
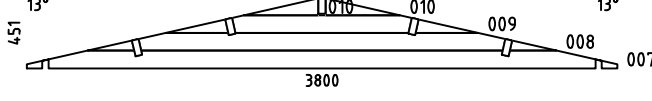
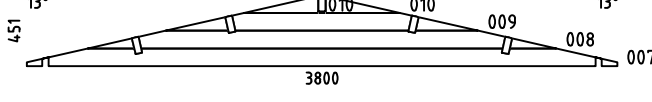
Pos	Specification-Spezifikation-Specificatie-Nomenclature-Elementi-Especificacion Lapland 40 A	Qty	Profile (mm)	Lenght (mm)
001		2	40x57	1095
002		12	40x114	240
003		12	40x114	240
004		6	40x114	1095
005		2	40x57	1095
006		35	40x114	3800
011		2	40x57	3800
012		32	40x114	320
013		32	40x114	320
014		1	40x114	3800
015		6	40x114	5740
016		2	40x114	5740
017		14	40x114	1510
018		2	40x114	5740
019		1	40x114	5940
020		1	40x114	5940
EXTRA		1	40x114	5740
W1-1		1		
W2-1		1		
W3-1		1		
Model Lapland 40 A		Material		Page 1/3

Pos	Specification-Spezifikation-Specificatie-Nomenclature-Elementi-Especificacion Lapland 40 A	Qty	Profile (mm)	Lenght (mm)
PL1		4	44x144	5940
PL2		1	44x144	5940
R-1	Roof board-Dachbrett-Dakplank-Volige-Tavola tetto-Tabla de tejado	136+1 105+1	88x18 114x18	2110
	-POST 8.5x8.5	2	85x85	1005
GB-1	Gable board 95-Giebelblende-Gevelplank-Planche de rive-Tavola di bordo-Tabla de borde	4	18x95	2970
GB-1	Gable board 120-Giebelblende-Gevelplank-Planche de rive-Tavola di bordo-Tabla de borde	4	18x120	2150
	Handrail 70-Handlauf-Leuning-Rampe-Corrimano-Pasamano 1.8x7	2	18x70	1080
	Handrail 70-Handlauf-Leuning-Rampe-Corrimano-Pasamano 1.8x7	2	18x70	1875
RL-1	Roofing lath 3000-Giebelleiste-Gevellijst-Latte de rive-Listello di bordo-Listones de borde	8	18x40	24rmt.
SS-1	Storm slat kit-Sturmleiste satz-Stormanker set-Kit de latte anti tempête-Kit listello di tempesta-Kit liston anti tormenta	4	18x40	2000
	U Profile	2		798
	Adjustable foot kit-Pfostenträger-Paalhouder-Pied de poteau-Portapilastri-Base para poste	2		
D	Diamond	2		
	Double door kit-Doppeltür satz-Dubbele deur set-Kit double porte-Kit porta-Kit para puerta	1		
	Nail 1.6x30-Nagel-Spijker-Clou-Chiodo-Clavo	40	1.6x30	
	Nail 1.8x40-Nagel-Spijker-Clou-Chiodo-Clavo	550	1.8x40	
	Ventilation panel kit-Außengitter-Schoepenrooster-Panneau de ventilation-Griglia di ventilazione-Rejilla de ventilacion	1		
	Window stay-Fensterfeststeller-Raamuitzetter-Limiteur d'ouverture fenêtrre-Vento bretelle-Soporte de ventana	1		
	WINDOW 770x770 W0-4N 770x770-40 	1		
Model	Lapland 40 A	Material	Page	2/3

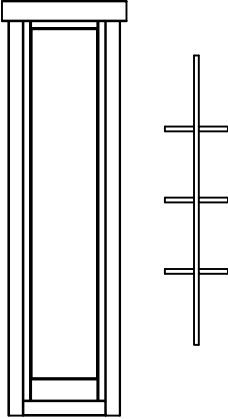
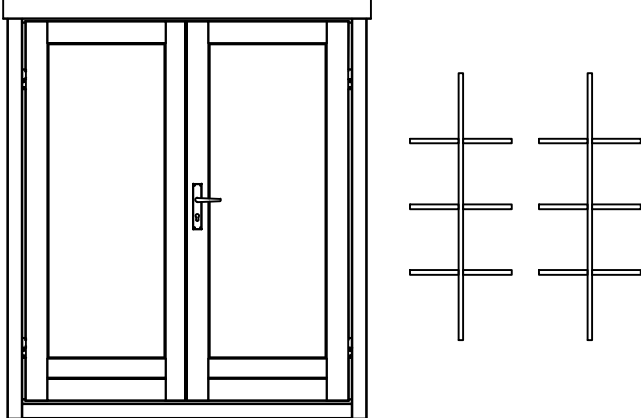
Pos	Specification-Spezifikation-Specificatie-Nomenclature-Elementi-Especificacion Lapland 40 A	Qty	Profile (mm)	Lenght (mm)
	<p data-bbox="651 152 874 206">WINDOW 445x1850 W0-8 H 445x1850-40</p> 	2		
	<p data-bbox="635 680 890 734">DOOR 1600x1850 DD08-8 H 1600x1850-40</p> 	1		
Model	Lapland 40 A	Material	Page	3/3

H = 1.700 m  
TOTAL: 19.08 m2

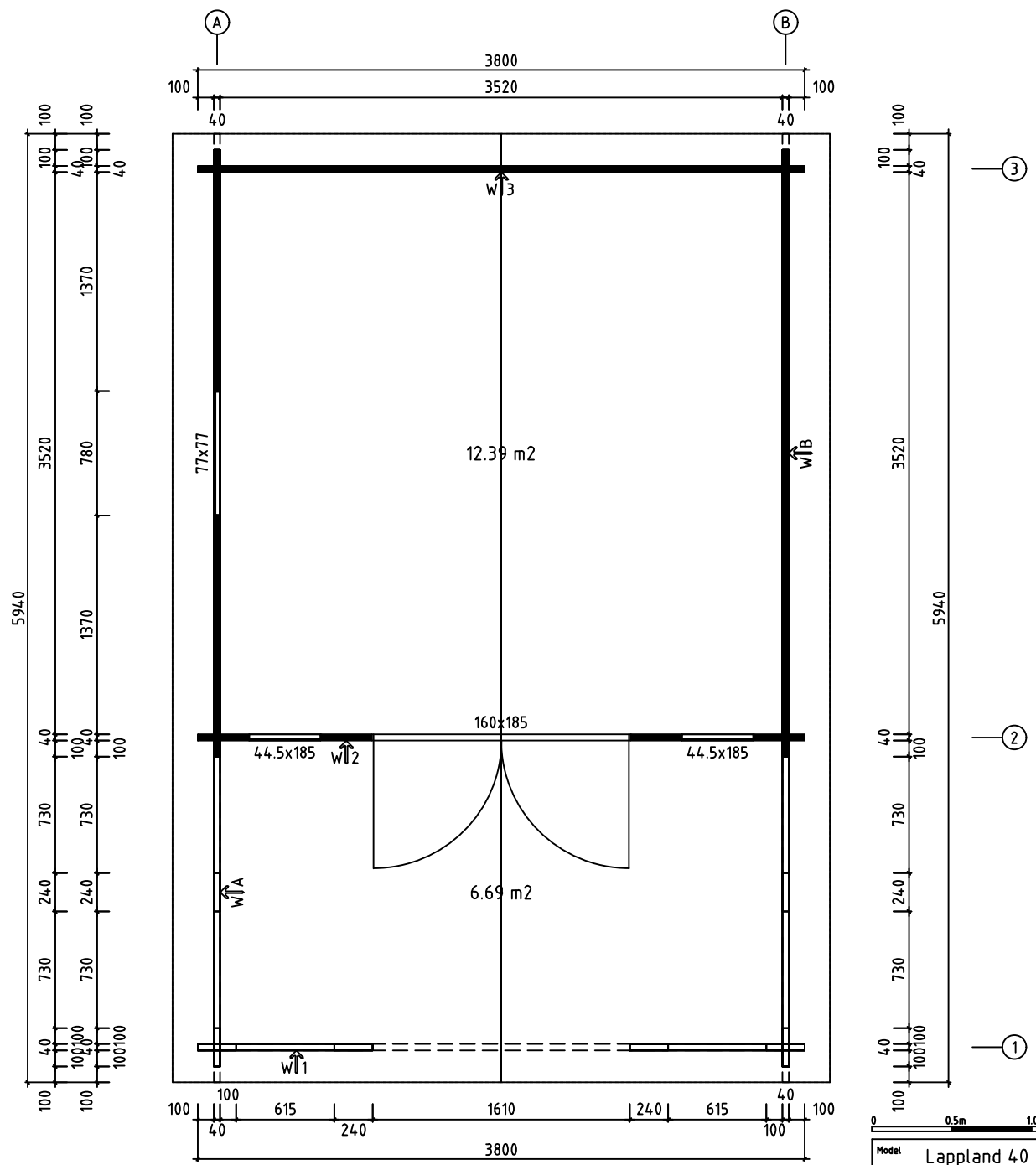

Model	Lapland 40 A	Drawing	PLAN	Page			
		Drawn by	J.S	Material	40x114	Scale	1:30
		Date	16.04.2024	File	Lapland 40 A.dwg		



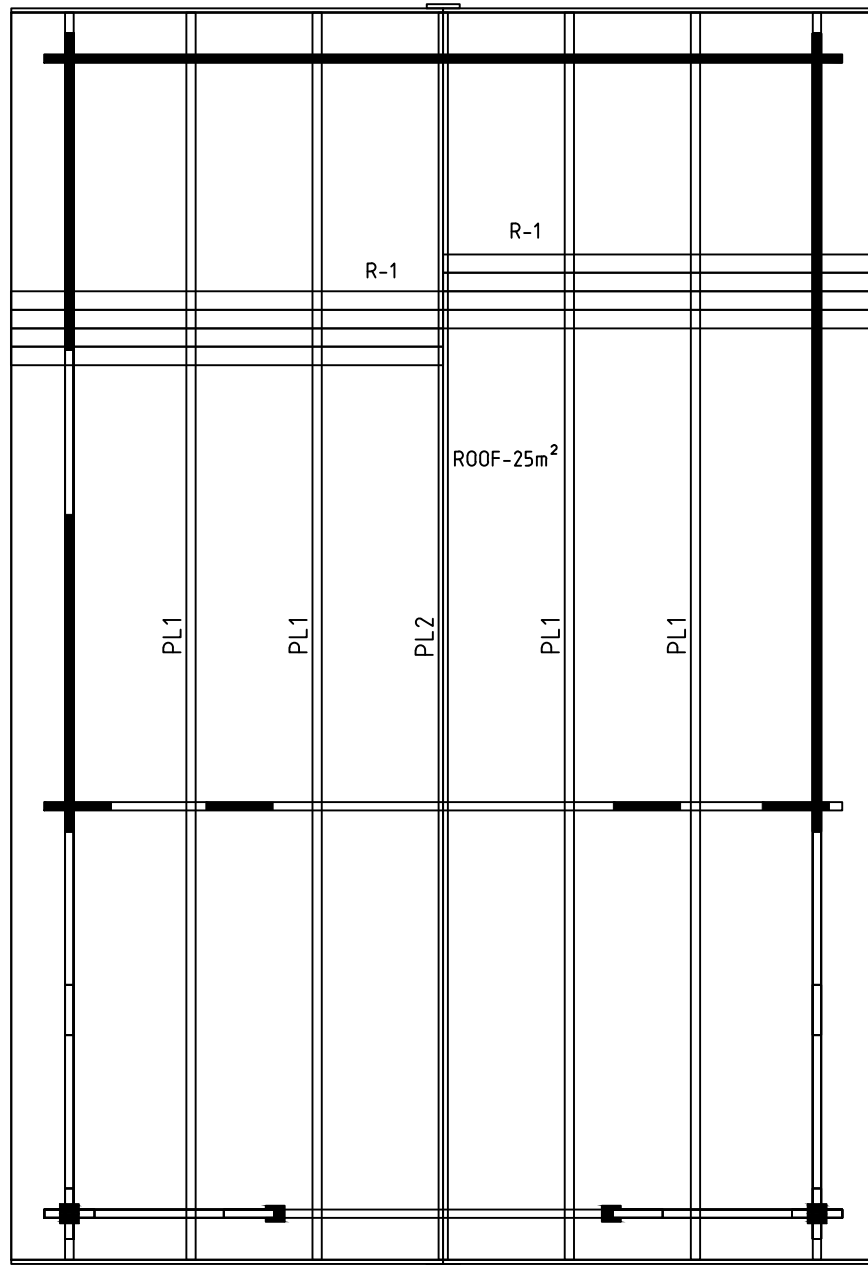



0 0.5m 1.0m 2.0m

Model	Lapland 40 A	Drawing	ROOF	Page
	Drawn by	J.S	Material	40x114
	Date	16.04.2024	File	Lapland 40 A.dwg
			Scale	1:30

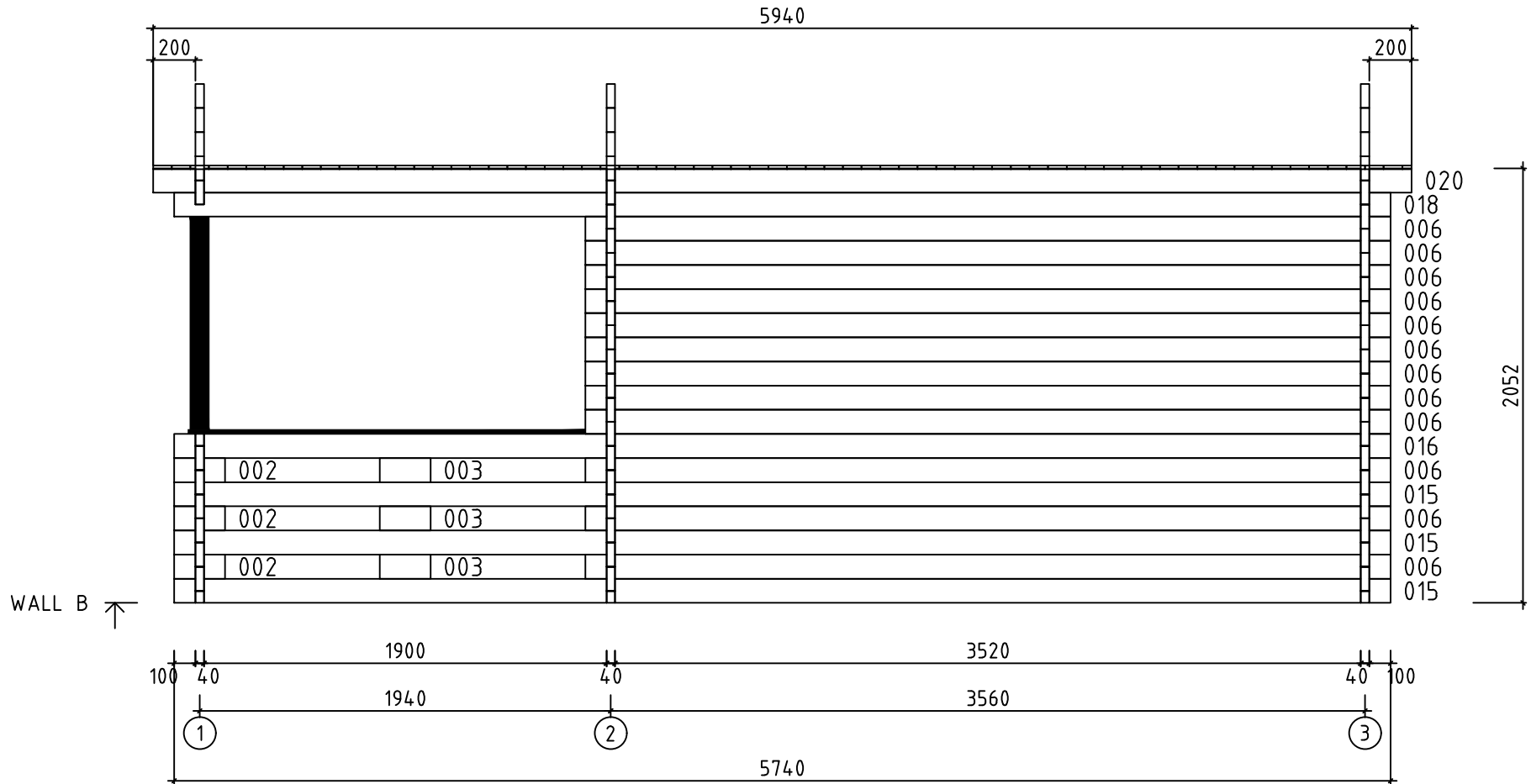



0 0.5m 1.0m 2.0m

Model	Lapland 40 A	Drawing	WALL B	Page	3	
	Drawn by	J.S	Material	4x11.4	Scale	1:30
	Date	16.04.2024	File	Lapland 40 A.dwg		

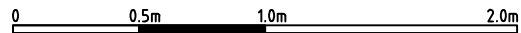
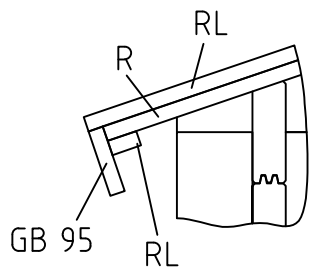
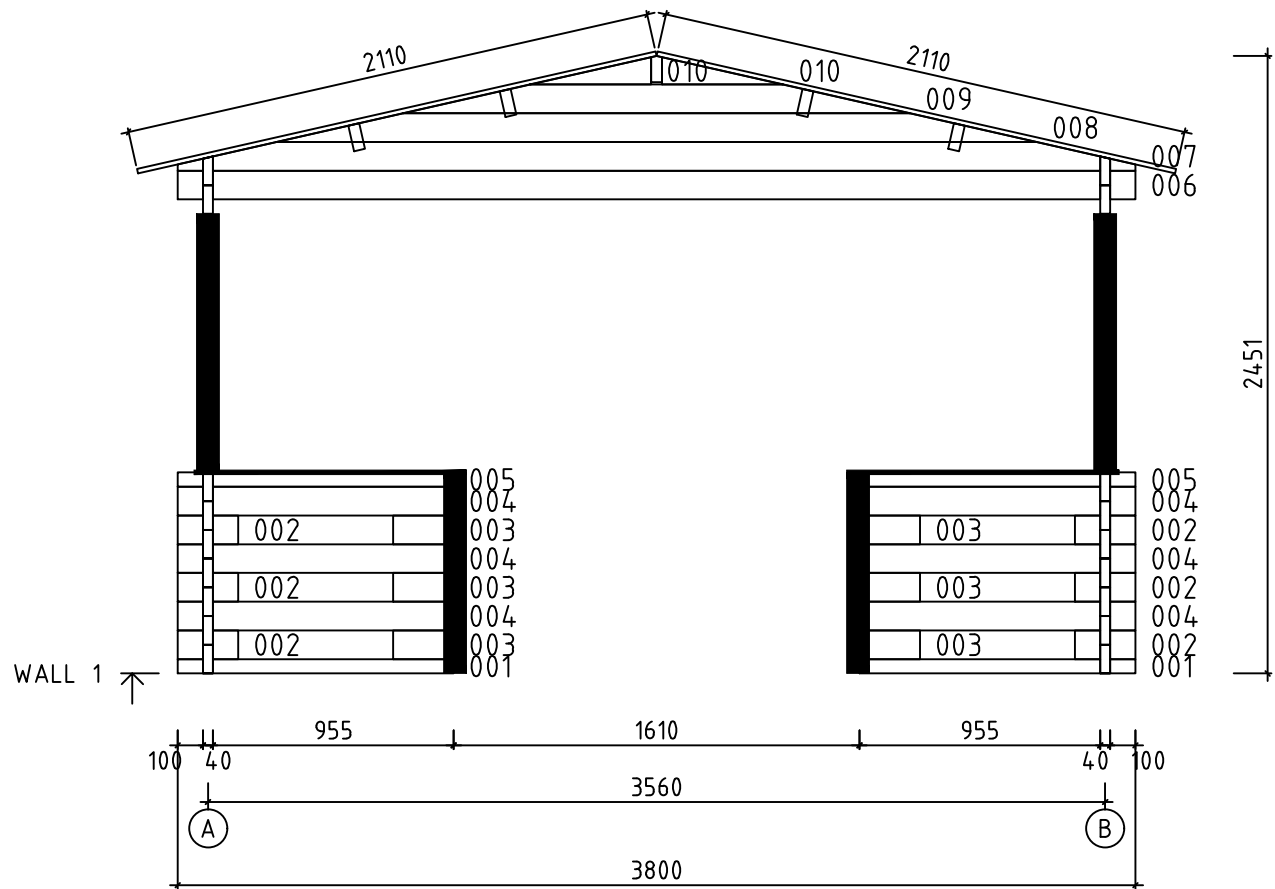

Model	Lapland 40 A	Drawing	WALL 1	Page	5	
	Drawn by	J.S	Material	4x11.4	Scale	1:30
	Date	16.04.2024	File	Lapland 40 A.dwg		

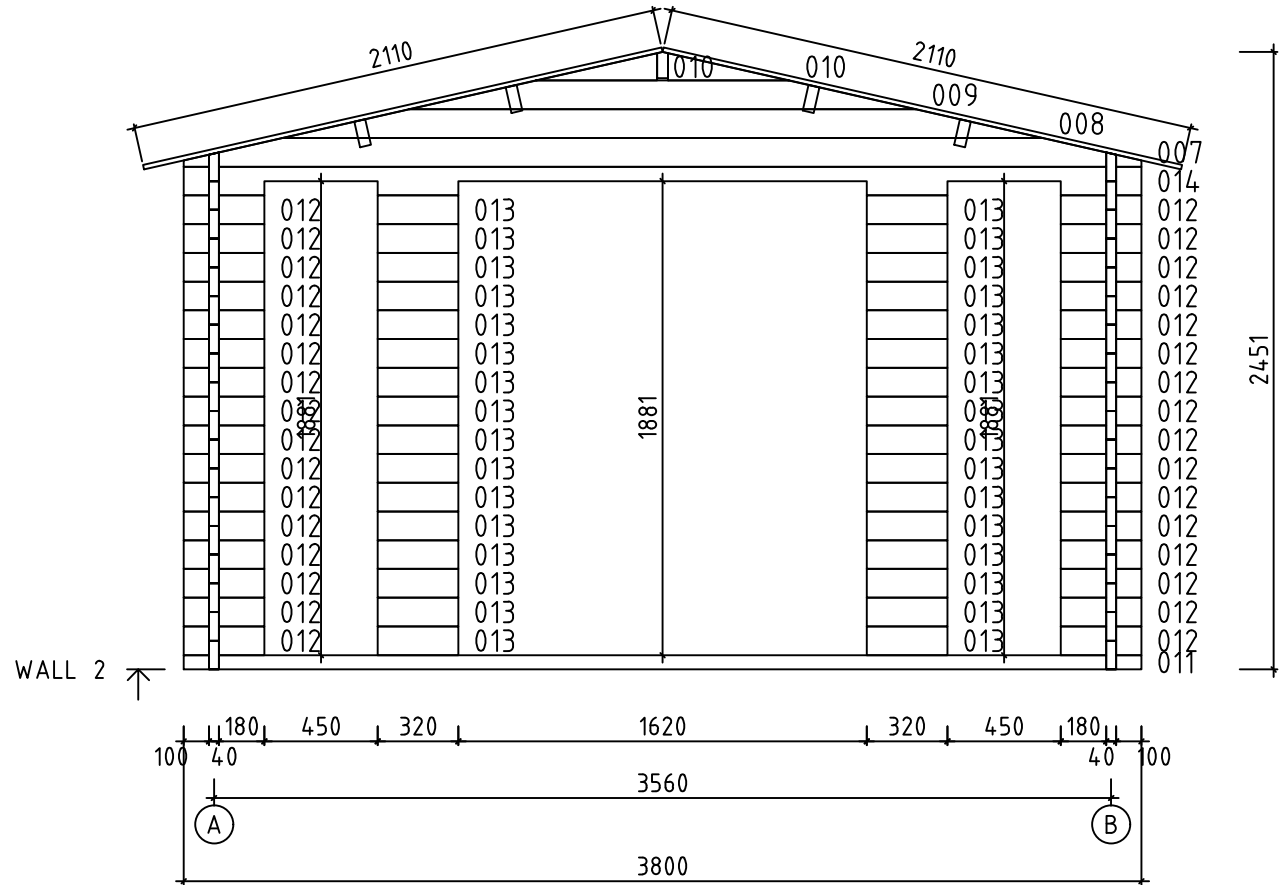

0 0.5m 1.0m 2.0m

Model	Lapland 40 A	Drawing	WALL 2	Page	6	
	Drawn by	J.S	Material	4x11.4	Scale	1:30
	Date	16.04.2024	File	Lapland 40 A.dwg		

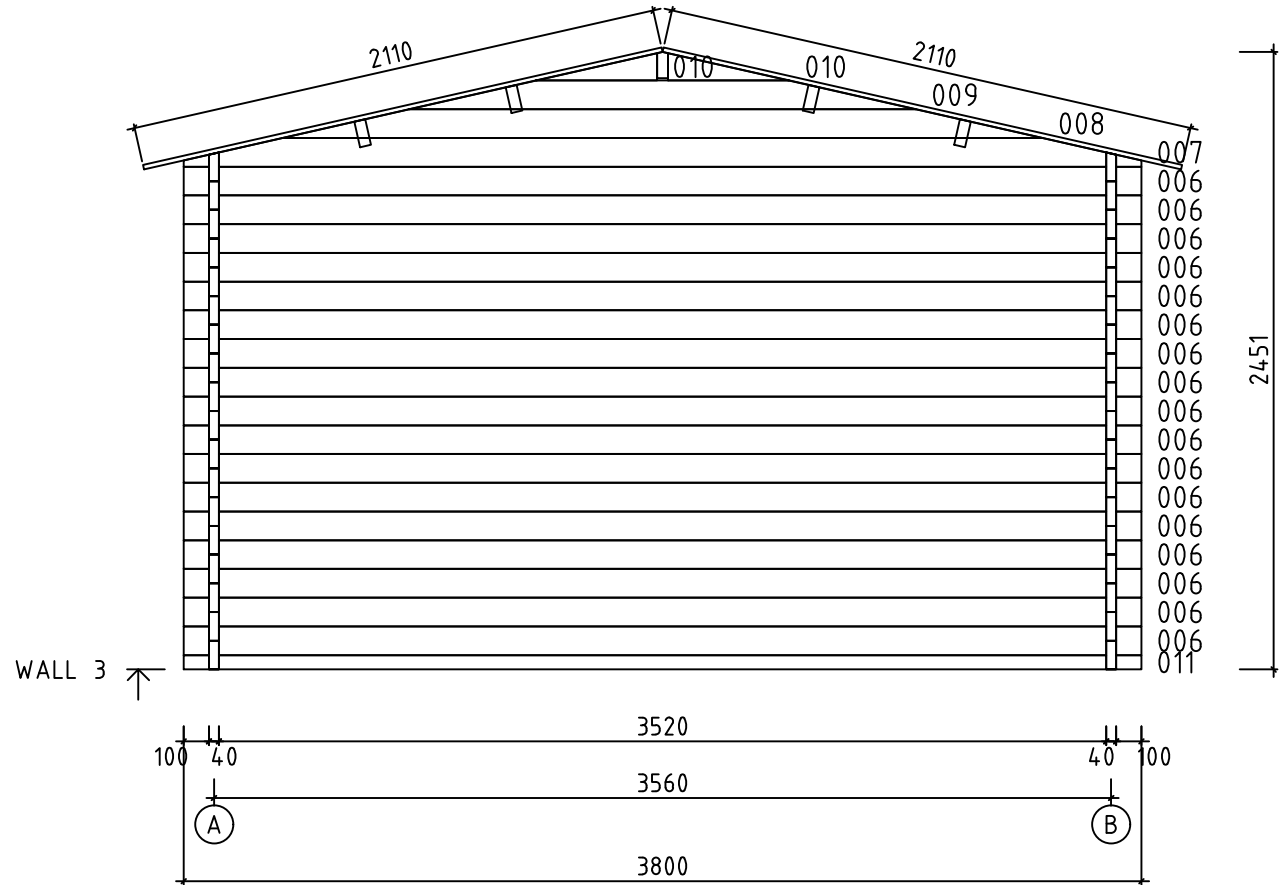

0 0.5m 1.0m 2.0m

Model	Lapland 40 A	Drawing	WALL 3	Page	7	
	Drawn by	J.S	Material	4x11.4	Scale	1:30
	Date	16.04.2024	File	Lapland 40 A.dwg		